

16

H8S/2111B

Hardware Manual

Renesas 16-Bit Single-Chip Microcomputer
H8S Family / H8S/2100 Series

H8S/2111B

HD64F2111B

Keep safety first in your circuit designs!

1. Renesas Technology Corp. puts the maximum effort into making semiconductor products better and more reliable, but there is always the possibility that trouble may occur with them. Trouble with semiconductors may lead to personal injury, fire or property damage.
Remember to give due consideration to safety when making your circuit designs, with appropriate measures such as (i) placement of substitutive, auxiliary circuits, (ii) use of nonflammable material or (iii) prevention against any malfunction or mishap.

Notes regarding these materials

1. These materials are intended as a reference to assist our customers in the selection of the Renesas Technology Corp. product best suited to the customer's application; they do not convey any license under any intellectual property rights, or any other rights, belonging to Renesas Technology Corp. or a third party.
2. Renesas Technology Corp. assumes no responsibility for any damage, or infringement of any third-party's rights, originating in the use of any product data, diagrams, charts, programs, algorithms, or circuit application examples contained in these materials.
3. All information contained in these materials, including product data, diagrams, charts, programs and algorithms represents information on products at the time of publication of these materials, and are subject to change by Renesas Technology Corp. without notice due to product improvements or other reasons. It is therefore recommended that customers contact Renesas Technology Corp. or an authorized Renesas Technology Corp. product distributor for the latest product information before purchasing a product listed herein.
The information described here may contain technical inaccuracies or typographical errors. Renesas Technology Corp. assumes no responsibility for any damage, liability, or other loss rising from these inaccuracies or errors.
Please also pay attention to information published by Renesas Technology Corp. by various means, including the Renesas Technology Corp. Semiconductor home page (<http://www.renesas.com>).
4. When using any or all of the information contained in these materials, including product data, diagrams, charts, programs, and algorithms, please be sure to evaluate all information as a total system before making a final decision on the applicability of the information and products. Renesas Technology Corp. assumes no responsibility for any damage, liability or other loss resulting from the information contained herein.
5. Renesas Technology Corp. semiconductors are not designed or manufactured for use in a device or system that is used under circumstances in which human life is potentially at stake. Please contact Renesas Technology Corp. or an authorized Renesas Technology Corp. product distributor when considering the use of a product contained herein for any specific purposes, such as apparatus or systems for transportation, vehicular, medical, aerospace, nuclear, or undersea repeater use.
6. The prior written approval of Renesas Technology Corp. is necessary to reprint or reproduce in whole or in part these materials.
7. If these products or technologies are subject to the Japanese export control restrictions, they must be exported under a license from the Japanese government and cannot be imported into a country other than the approved destination.
Any diversion or reexport contrary to the export control laws and regulations of Japan and/or the country of destination is prohibited.
8. Please contact Renesas Technology Corp. for further details on these materials or the products contained therein.

General Precautions on Handling of Product

1. Treatment of NC Pins

Note: Do not connect anything to the NC pins.

The NC (not connected) pins are either not connected to any of the internal circuitry or are used as test pins or to reduce noise. If something is connected to the NC pins, the operation of the LSI is not guaranteed.

2. Treatment of Unused Input Pins

Note: Fix all unused input pins to high or low level.

Generally, the input pins of CMOS products are high-impedance input pins. If unused pins are in their open states, intermediate levels are induced by noise in the vicinity, a pass-through current flows internally, and a malfunction may occur.

3. Processing before Initialization

Note: When power is first supplied, the product's state is undefined.

The states of internal circuits are undefined until full power is supplied throughout the chip and a low level is input on the reset pin. During the period where the states are undefined, the register settings and the output state of each pin are also undefined. Design your system so that it does not malfunction because of processing while it is in this undefined state. For those products which have a reset function, reset the LSI immediately after the power supply has been turned on.

4. Prohibition of Access to Undefined or Reserved Addresses

Note: Access to undefined or reserved addresses is prohibited.

The undefined or reserved addresses may be used to expand functions, or test registers may have been allocated to these addresses. Do not access these registers; the system's operation is not guaranteed if they are accessed.

Configuration of This Manual

This manual comprises the following items:

1. General Precautions on Handling of Product
2. Configuration of This Manual
3. Preface
4. Contents
5. Overview
6. Description of Functional Modules
 - CPU and System-Control Modules
 - On-Chip Peripheral Modules

The configuration of the functional description of each module differs according to the module. However, the generic style includes the following items:

- i) Feature
- ii) Input/Output Pin
- iii) Register Description
- iv) Operation
- v) Usage Note

When designing an application system that includes this LSI, take notes into account. Each section includes notes in relation to the descriptions given, and usage notes are given, as required, as the final part of each section.

7. List of Registers
8. Electrical Characteristics
9. Appendix
10. Main Revisions and Additions in this Edition (only for revised versions)

The list of revisions is a summary of points that have been revised or added to earlier versions. This does not include all of the revised contents. For details, see the actual locations in this manual.

11. Index

Preface

The H8S/2111B is a microcomputer (MCU) made up of the H8S/2000 CPU employing Renesas Technology's original architecture as its core, and the peripheral functions required to configure a system.

The H8S/2000 CPU has an internal 32-bit configuration, sixteen 16-bit general registers, and a simple and optimized instruction set for high-speed operation. The H8S/2000 CPU can handle a 16-Mbyte linear address space.

This LSI is equipped with ROM, RAM, a 16-bit free-running timer (FRT), an 8-bit timer (TMR), a watchdog timer (WDT), a serial communication interface (SCI), a keyboard buffer controller, a host interface (LPC), an I²C bus interface (IIC), and I/O ports as on-chip peripheral modules, required for system configuration.

A flash memory (F-ZTAT^{TM*}) version is available for this LSI's ROM. This provides flexibility as it can be reprogrammed in no time to cope with all situations from the early stages of mass production to full-scale mass production. This is particularly applicable to application devices with specifications that will most probably change.

Note: * F-ZTATTM is a trademark of Renesas Technology Corp.

Target Users: This manual was written for users who will be using the H8S/2111B in the design of application systems. Target users are expected to understand the fundamentals of electrical circuits, logical circuits, and microcomputers.

Objective: This manual was written to explain the hardware functions and electrical characteristics of the H8S/2111B to the target users.
Refer to the H8S/2600 Series, H8S/2000 Series Programming Manual for a detailed description of the instruction set.

Notes on reading this manual:

- In order to understand the overall functions of the chip
Read the manual according to the contents. This manual can be roughly categorized into parts on the CPU, system control functions, peripheral functions and electrical characteristics.
- In order to understand the details of the CPU's functions
Read the H8S/2600 Series, H8S/2000 Series Programming Manual.
- In order to understand the details of a register when its name is known
Read the index that is the final part of the manual to find the page number of the entry on the register. The addresses, bits, and initial values of the registers are summarized in section 21, List of Registers.

Rules: Register name: The following notation is used for cases when the same or a similar function, e.g. serial communication interface, is implemented on more than one channel:
 XXX_N (XXX is the register name and N is the channel number)

Bit order: The MSB is on the left and the LSB is on the right.

Number notation: Binary is B'xxxx, hexadecimal is H'xxxx, decimal is xxxx.

Signal notation: An overbar is added to a low-active signal: $\overline{\text{xxxx}}$

Related Manuals: The latest versions of all related manuals are available from our web site. Please ensure you have the latest versions of all documents you require.
<http://www.renesas.com/eng/>

H8S/2111B manuals:

Document Title	Document No.
H8S/2111B Hardware Manual	This manual
H8S/2600 Series, H8S/2000 Series Programming Manual	REJ09B0139

User's manuals for development tools:

Document Title	Document No.
H8S, H8/300 Series C/C++ Compiler, Assembler, Optimizing Linkage Editor User's Manual	REJ10B0058
Microcomputer Development Environment System H8S, H8/300 Series Simulator/Debugger User's Manual	ADE-702-282
H8S, H8/300 Series High-performance Embedded Workshop 3 Tutorial	REJ10B0024
H8S, H8/300 Series High-performance Embedded Workshop 3 User's Manual	REJ10B0026

Contents

Section 1	Overview.....	1
1.1	Features.....	1
1.2	Internal Block Diagram.....	2
1.3	Pin Description.....	3
1.3.1	Pin Arrangement.....	3
1.3.2	Pin Functions in Each Operating Mode.....	4
1.3.3	Pin Functions.....	9
Section 2	CPU.....	13
2.1	Features.....	13
2.1.1	Differences between H8S/2600 CPU and H8S/2000 CPU.....	14
2.1.2	Differences from H8/300 CPU.....	15
2.1.3	Differences from H8/300H CPU.....	15
2.2	CPU Operating Modes.....	16
2.2.1	Normal Mode.....	16
2.2.2	Advanced Mode.....	18
2.3	Address Space.....	20
2.4	Register Configuration.....	21
2.4.1	General Registers.....	22
2.4.2	Program Counter (PC).....	23
2.4.3	Extended Control Register (EXR).....	23
2.4.4	Condition-Code Register (CCR).....	24
2.4.5	Initial Register Values.....	25
2.5	Data Formats.....	26
2.5.1	General Register Data Formats.....	26
2.5.2	Memory Data Formats.....	28
2.6	Instruction Set.....	29
2.6.1	Table of Instructions Classified by Function.....	30
2.6.2	Basic Instruction Formats.....	39
2.7	Addressing Modes and Effective Address Calculation.....	40
2.7.1	Register Direct—Rn.....	40
2.7.2	Register Indirect—@ERn.....	40
2.7.3	Register Indirect with Displacement—@(d:16, ERn) or @(d:32, ERn).....	41
2.7.4	Register Indirect with Post-Increment or Pre-Decrement—@ERn+ or @-ERn.....	41
2.7.5	Absolute Address—@aa:8, @aa:16, @aa:24, or @aa:32.....	41
2.7.6	Immediate—#xx:8, #xx:16, or #xx:32.....	42
2.7.7	Program-Counter Relative—@(d:8, PC) or @(d:16, PC).....	42
2.7.8	Memory Indirect—@@aa:8.....	43
2.7.9	Effective Address Calculation.....	44

2.8	Processing States.....	46
2.9	Usage Notes	48
2.9.1	Note on TAS Instruction Usage.....	48
2.9.2	Note on STM/LDM Instruction Usage	48
2.9.3	Note on Bit Manipulation Instructions	48
2.9.4	EEPMOV Instruction.....	49
Section 3 MCU Operating Modes		51
3.1	MCU Operating Mode Selection	51
3.2	Register Descriptions.....	52
3.2.1	Mode Control Register (MDCR)	52
3.2.2	System Control Register (SYSCR).....	53
3.2.3	Serial Timer Control Register (STCR)	55
3.3	Operating Mode Descriptions	56
3.3.1	Mode 2.....	56
3.3.2	Mode 3.....	56
3.4	Address Map.....	57
Section 4 Exception Handling		59
4.1	Exception Handling Types and Priority	59
4.2	Exception Sources and Exception Vector Table	60
4.3	Reset	61
4.3.1	Reset Exception Handling	61
4.3.2	Interrupts after Reset.....	62
4.3.3	On-Chip Peripheral Modules after Reset is Cancelled	62
4.4	Interrupt Exception Handling	63
4.5	Trap Instruction Exception Handling.....	63
4.6	Stack Status after Exception Handling.....	64
4.7	Usage Note.....	65
Section 5 Interrupt Controller.....		67
5.1	Features.....	67
5.2	Input/Output Pins	68
5.3	Register Descriptions.....	69
5.3.1	Interrupt Control Registers A to C (ICRA to ICRC)	69
5.3.2	Address Break Control Register (ABRKCR)	70
5.3.3	Break Address Registers A to C (BARA to BARC).....	71
5.3.4	IRQ Sense Control Registers (ISCRH, ISCRL).....	72
5.3.5	IRQ Enable Register (IER).....	73
5.3.6	IRQ Status Register (ISR).....	73
5.3.7	Keyboard Matrix Interrupt Mask Registers (KMIMRA, KMIMR) Wake-Up Event Interrupt Mask Register (WUEMRB).....	73
5.4	Interrupt Sources.....	76

5.4.1	External Interrupts	76
5.4.2	Internal Interrupts	77
5.5	Interrupt Exception Handling Vector Table.....	78
5.6	Interrupt Control Modes and Interrupt Operation	80
5.6.1	Interrupt Control Mode 0.....	80
5.6.2	Interrupt Control Mode 1	82
5.6.3	Interrupt Exception Handling Sequence	85
5.6.4	Interrupt Response Times	86
5.7	Address Break.....	87
5.7.1	Features.....	87
5.7.2	Block Diagram.....	87
5.7.3	Operation	88
5.7.4	Usage Notes	88
5.8	Usage Notes	90
5.8.1	Conflict between Interrupt Generation and Disabling	90
5.8.2	Instructions that Disable Interrupts	91
5.8.3	Interrupts during Execution of EEPMOV Instruction.....	91
5.8.4	IRQ Status Register (ISR).....	91
Section 6 Bus Controller (BSC).....		93
6.1	Register Descriptions	93
6.1.1	Bus Control Register (BCR)	93
6.1.2	Wait State Control Register (WSCR)	94
Section 7 I/O Ports		95
7.1	Port 1.....	100
7.1.1	Port 1 Data Direction Register (P1DDR).....	100
7.1.2	Port 1 Data Register (P1DR).....	100
7.1.3	Port 1 Pull-Up MOS Control Register (P1PCR).....	101
7.1.4	Pin Functions	101
7.1.5	Port 1 Input Pull-Up MOS	102
7.2	Port 2.....	102
7.2.1	Port 2 Data Direction Register (P2DDR).....	102
7.2.2	Port 2 Data Register (P2DR)	103
7.2.3	Port 2 Pull-Up MOS Control Register (P2PCR).....	103
7.2.4	Pin Functions	103
7.2.5	Port 2 Input Pull-Up MOS	104
7.3	Port 3.....	104
7.3.1	Port 3 Data Direction Register (P3DDR).....	104
7.3.2	Port 3 Data Register (P3DR).....	105
7.3.3	Port 3 Pull-Up MOS Control Register (P3PCR).....	105
7.3.4	Pin Functions	106
7.3.5	Port 3 Input Pull-Up MOS	106

7.4	Port 4.....	107
7.4.1	Port 4 Data Direction Register (P4DDR).....	107
7.4.2	Port 4 Data Register (P4DR)	107
7.4.3	Pin Functions	108
7.5	Port 5.....	110
7.5.1	Port 5 Data Direction Register (P5DDR).....	110
7.5.2	Port 5 Data Register (P5DR)	110
7.5.3	Pin Functions	111
7.6	Port 6.....	112
7.6.1	Port 6 Data Direction Register (P6DDR).....	112
7.6.2	Port 6 Data Register (P6DR)	113
7.6.3	Port 6 Pull-Up MOS Control Register (KMPCR)	113
7.6.4	System Control Register 2 (SYSCR2).....	114
7.6.5	Pin Functions	114
7.6.6	Port 6 Input Pull-Up MOS	116
7.7	Port 7.....	117
7.7.1	Port 7 Input Data Register (P7PIN)	117
7.7.2	Pin Functions	117
7.8	Port 8.....	118
7.8.1	Port 8 Data Direction Register (P8DDR).....	118
7.8.2	Port 8 Data Register (P8DR)	118
7.8.3	Pin Functions	119
7.9	Port 9.....	122
7.9.1	Port 9 Data Direction Register (P9DDR).....	122
7.9.2	Port 9 Data Register (P9DR)	122
7.9.3	Pin Functions	123
7.10	Port A.....	125
7.10.1	Port A Data Direction Register (PADDDR).....	125
7.10.2	Port A Output Data Register (PAODR).....	125
7.10.3	Port A Input Data Register (PAPIN)	126
7.10.4	Pin Functions	126
7.10.5	Port A Input Pull-Up MOS	128
7.11	Port B.....	129
7.11.1	Port B Data Direction Register (PBDDR)	129
7.11.2	Port B Output Data Register (PBODR)	129
7.11.3	Port B Input Data Register (PBPIN).....	130
7.11.4	Pin Functions	130
7.11.5	Port B Input Pull-Up MOS	131
7.12	Ports C, D.....	132
7.12.1	Port C and Port D Data Direction Registers (PCDDR, PDDDR)	132
7.12.2	Port C and Port D Output Data Registers (PCODR, PDODR)	133
7.12.3	Port C and Port D Input Data Registers (PCPIN, PDPIN).....	133
7.12.4	Port C and Port D Nch-OD Control Register (PCNOCR, PDNOCR)	134

7.12.5	Pin Functions	135
7.12.6	Input Pull-Up MOS in Ports C and D	135
7.13	Ports E, F.....	136
7.13.1	Port E and Port F Data Direction Registers (PEDDR, PFDDR).....	136
7.13.2	Port E and Port F Output Data Registers (PEODR, PFODR).....	137
7.13.3	Port E and Port F Input Data Registers (PEPIN, PFPIN).....	138
7.13.4	Pin Functions	138
7.13.5	Port E and Port F Nch-OD Control Register (PENOCR, PFNOCR).....	140
7.13.6	Pin Functions	141
7.13.7	Input Pull-Up MOS in Ports E and F.....	141
7.14	Port G.....	142
7.14.1	Port G Data Direction Register (PGDDR).....	142
7.14.2	Port G Output Data Register (PGODR).....	143
7.14.3	Port G Input Data Register (PGPIN).....	143
7.14.4	Pin Functions	144
7.14.5	Port G Nch-OD Control Register (PGNOCR).....	145
7.14.6	Pin Functions	145
Section 8 8-Bit PWM Timer (PWM).....		147
8.1	Features.....	147
8.2	Input/Output Pins.....	148
8.3	Register Descriptions	148
8.3.1	PWM Register Select (PWSL).....	149
8.3.2	PWM Data Registers 7 to 0 (PWDR7 to PWD0).....	151
8.3.3	PWM Data Polarity Register A (PWDPRA)	151
8.3.4	PWM Output Enable Register A (PWOERA)	152
8.3.5	Peripheral Clock Select Register (PCSR)	152
8.4	Operation	153
8.4.1	PWM Setting Example	155
8.4.2	Diagram of PWM Used as D/A Converter	155
8.5	Usage Notes	156
8.5.1	Module Stop Mode Setting	156
Section 9 16-Bit Free-Running Timer (FRT)		157
9.1	Features.....	157
9.2	Input/Output Pins.....	159
9.3	Register Descriptions	159
9.3.1	Free-Running Counter (FRC)	160
9.3.2	Output Compare Registers A and B (OCRA, OCRB)	160
9.3.3	Input Capture Registers A to D (ICRA to ICRD).....	160
9.3.4	Output Compare Registers AR and AF (OCRAR, OCRAF)	161
9.3.5	Output Compare Register DM (OCRDM).....	161
9.3.6	Timer Interrupt Enable Register (TIER).....	162

9.3.7	Timer Control/Status Register (TCSR).....	163
9.3.8	Timer Control Register (TCR).....	166
9.3.9	Timer Output Compare Control Register (TOCR)	167
9.4	Operation	169
9.4.1	Pulse Output	169
9.5	Operation Timing.....	170
9.5.1	FRC Increment Timing.....	170
9.5.2	Output Compare Output Timing.....	171
9.5.3	FRC Clear Timing	171
9.5.4	Input Capture Input Timing	172
9.5.5	Buffered Input Capture Input Timing	173
9.5.6	Timing of Input Capture Flag (ICF) Setting	174
9.5.7	Timing of Output Compare Flag (OCF) setting.....	174
9.5.8	Timing of FRC Overflow Flag Setting	175
9.5.9	Automatic Addition Timing.....	175
9.5.10	Mask Signal Generation Timing.....	176
9.6	Interrupt Sources.....	177
9.7	Usage Notes.....	177
9.7.1	Conflict between FRC Write and Clear	177
9.7.2	Conflict between FRC Write and Increment.....	178
9.7.3	Conflict between OCR Write and Compare-Match	178
9.7.4	Switching of Internal Clock and FRC Operation.....	180
9.7.5	Module Stop Mode Setting	181
Section 10	8-Bit Timer (TMR).....	183
10.1	Features.....	183
10.2	Input/Output Pins.....	188
10.3	Register Descriptions.....	189
10.3.1	Timer Counter (TCNT).....	191
10.3.2	Time Constant Register A (TCORA)	191
10.3.3	Time Constant Register B (TCORB).....	191
10.3.4	Timer Control Register (TCR).....	192
10.3.5	Timer Control/Status Register (TCSR).....	196
10.3.6	Time Constant Register (TCORC).....	202
10.3.7	Input Capture Registers R and F (TICRR, TICRF, TICRR_A and TICRF_A) ...	202
10.3.8	Timer Input Select Register (TISR and TISR_B).....	202
10.3.9	Timer Connection Register I (TCONRI)	203
10.3.10	Timer Connection Register S (TCONRS)	203
10.3.11	Timer XY Control Register (TCRXY)	204
10.3.12	Timer AB Control Register (TCRAB).....	205
10.4	Operation	206
10.4.1	Pulse Output	206
10.5	Operation Timing.....	207

10.5.1	TCNT Count Timing	207
10.5.2	Timing of CMFA and CMFB Setting at Compare-Match	207
10.5.3	Timing of Timer Output at Compare-Match.....	208
10.5.4	Timing of Counter Clear at Compare-Match	208
10.5.5	TCNT External Reset Timing	209
10.5.6	Timing of Overflow Flag (OVF) Setting	209
10.6	TMR_0 and TMR_1 Cascaded Connection	210
10.6.1	16-Bit Count Mode	210
10.6.2	Compare-Match Count Mode	210
10.7	TMR_Y and TMR_X Cascaded Connection	211
10.7.1	16-Bit Count Mode	211
10.7.2	Compare-Match Count Mode	211
10.7.3	Input Capture Operation	212
10.8	TMR_B and TMR_A Cascaded Connection	212
10.8.1	16-Bit Count Mode	212
10.8.2	Compare-Match Count Mode	212
10.8.3	Input Capture Operation	213
10.9	Interrupt Sources.....	215
10.10	Usage Notes	216
10.10.1	Conflict between TCNT Write and Counter Clear.....	216
10.10.2	Conflict between TCNT Write and Count-Up	216
10.10.3	Conflict between TCOR Write and Compare-Match.....	217
10.10.4	Conflict between Compare-Matches A and B	217
10.10.5	Switching of Internal Clocks and TCNT Operation.....	218
10.10.6	Mode Setting with Cascaded Connection	219
10.10.7	Module Stop Mode Setting	219
Section 11 Watchdog Timer (WDT).....		221
11.1	Features	221
11.2	Input/Output Pins	223
11.3	Register Descriptions	223
11.3.1	Timer Counter (TCNT).....	223
11.3.2	Timer Control/Status Register (TCSR).....	224
11.4	Operation	227
11.4.1	Watchdog Timer Mode	227
11.4.2	Interval Timer Mode.....	229
11.4.3	$\overline{\text{RESO}}$ Signal Output Timing	230
11.5	Interrupt Sources.....	230
11.6	Usage Notes	231
11.6.1	Notes on Register Access.....	231
11.6.2	Conflict between Timer Counter (TCNT) Write and Increment.....	232
11.6.3	Changing Values of CKS2 to CKS0 Bits.....	232
11.6.4	Switching between Watchdog Timer Mode and Interval Timer Mode.....	232

11.6.5	System Reset by $\overline{\text{RESO}}$ Signal	233
11.6.6	Counter Values during Transitions between High-Speed, Sub-Active, and Watch Modes	233
Section 12 Serial Communication Interface (SCI)		235
12.1	Features.....	235
12.2	Input/Output Pins	236
12.3	Register Descriptions.....	237
12.3.1	Receive Shift Register (RSR)	237
12.3.2	Receive Data Register (RDR).....	237
12.3.3	Transmit Data Register (TDR).....	237
12.3.4	Transmit Shift Register (TSR).....	238
12.3.5	Serial Mode Register (SMR)	238
12.3.6	Serial Control Register (SCR)	239
12.3.7	Serial Status Register (SSR)	241
12.3.8	Serial Interface Mode Register (SCMR).....	243
12.3.9	Bit Rate Register (BRR)	244
12.3.10	Serial Pin Select Register (SPSR).....	249
12.4	Operation in Asynchronous Mode	249
12.4.1	Data Transfer Format.....	250
12.4.2	Receive Data Sampling Timing and Reception Margin in Asynchronous Mode	251
12.4.3	Clock.....	251
12.4.4	SCI Initialization (Asynchronous Mode).....	253
12.4.5	Data Transmission (Asynchronous Mode)	254
12.4.6	Serial Data Reception (Asynchronous Mode)	256
12.5	Multiprocessor Communication Function.....	259
12.5.1	Multiprocessor Serial Data Transmission	260
12.5.2	Multiprocessor Serial Data Reception	261
12.6	Operation in Clocked Synchronous Mode	264
12.6.1	Clock.....	264
12.6.2	SCI Initialization (Clocked Synchronous Mode).....	265
12.6.3	Serial Data Transmission (Clocked Synchronous Mode)	266
12.6.4	Serial Data Reception (Clocked Synchronous Mode)	268
12.6.5	Simultaneous Serial Data Transmission and Reception (Clocked Synchronous Mode)	269
12.7	Interrupt Sources.....	271
12.8	Usage Notes	272
12.8.1	Module Stop Mode Setting	272
12.8.2	Break Detection and Processing	272
12.8.3	Mark State and Break Detection	272
12.8.4	Receive Error Flags and Transmit Operations (Clocked Synchronous Mode Only)	272
12.8.5	Relation between Writing to TDR and TDRE Flag	272

12.8.6	SCI Operations during Mode Transitions	273
12.8.7	Switching from SCK Pins to Port Pins	276
Section 13	I²C Bus Interface (IIC)	277
13.1	Features	277
13.2	Input/Output Pins	280
13.3	Register Descriptions	281
13.3.1	I ² C Bus Data Register (ICDR)	282
13.3.2	Slave Address Register (SAR)	283
13.3.3	Second Slave Address Register (SARX)	284
13.3.4	I ² C Bus Mode Register (ICMR)	286
13.3.5	I ² C Bus Control Register (ICCR)	289
13.3.6	I ² C Bus Status Register (ICSR)	297
13.3.7	DDC Switch Register (DDCSWR)	301
13.3.8	I ² C Bus Extended Control Register (ICXR)	302
13.3.9	Port G Control Register (PGCTL)	306
13.4	Operation	307
13.4.1	I ² C Bus Data Format	307
13.4.2	Initialization	309
13.4.3	Master Transmit Operation	309
13.4.4	Master Receive Operation	314
13.4.5	Slave Receive Operation	321
13.4.6	Slave Transmit Operation	328
13.4.7	IRIC Setting Timing and SCL Control	331
13.4.8	Noise Canceller	334
13.4.9	Initialization of Internal State	335
13.5	Interrupt Sources	336
13.6	Usage Notes	337
13.6.1	Module Stop Mode Setting	347
Section 14	Keyboard Buffer Controller	349
14.1	Features	349
14.2	Input/Output Pins	350
14.3	Register Descriptions	351
14.3.1	Keyboard Control Register H (KBCRH)	351
14.3.2	Keyboard Control Register L (KBCRL)	353
14.3.3	Keyboard Data Buffer Register (KBBR)	354
14.4	Operation	355
14.4.1	Receive Operation	355
14.4.2	Transmit Operation	356
14.4.3	Receive Abort	359
14.4.4	KCLKI and KDI Read Timing	361
14.4.5	KCLKO and KDO Write Timing	361

14.4.6	KBK Setting Timing and KCLK Control.....	362
14.4.7	Receive Timing.....	363
14.4.8	KCLK Fall Interrupt Operation	364
14.5	Usage Notes.....	365
14.5.1	KBIOE Setting and KCLK Falling Edge Detection	365
14.5.2	Module Stop Mode Setting	366
Section 15 Host Interface (LPC)		369
15.1	Features.....	369
15.2	Input/Output Pins.....	371
15.3	Register Descriptions.....	372
15.3.1	Host Interface Control Registers 0 and 1 (HICR0, HICR1)	373
15.3.2	Host Interface Control Registers 2 and 3 (HICR2, HICR3)	379
15.3.3	LPC Channel 3 Address Register (LADR3).....	381
15.3.4	Input Data Registers 1 to 3 (IDR1 to IDR3).....	382
15.3.5	Output Data Registers 1 to 3 (ODR1 to ODR3)	383
15.3.6	Bidirectional Data Registers 0 to 15 (TWR0 to TWR15).....	383
15.3.7	Status Registers 1 to 3 (STR1 to STR3)	383
15.3.8	SERIRQ Control Registers 0 and 1 (SIRQCR0, SIRQCR1)	389
15.3.9	Host Interface Select Register (HISEL).....	397
15.4	Operation	398
15.4.1	Host Interface Activation.....	398
15.4.2	LPC I/O Cycles.....	399
15.4.3	A20 Gate.....	400
15.4.4	Host Interface Shutdown Function (LPCPD)	403
15.4.5	Host Interface Serialized Interrupt Operation (SERIRQ)	407
15.4.6	Host Interface Clock Start Request (CLKRUN).....	409
15.5	Interrupt Sources.....	410
15.5.1	IBFI1, IBFI2, IBFI3, and ERRI.....	410
15.5.2	SMI, HIRQ1, HIRQ6, HIRQ9, HIRQ10, HIRQ11, and HIRQ12	410
15.6	Usage Notes.....	413
15.6.1	Module Stop Mode Setting	413
15.6.2	Notes on Using Host Interface.....	413
Section 16 A/D Converter		413
16.1	Features.....	413
16.2	Input/Output Pins.....	415
16.3	Register Descriptions.....	416
16.3.1	A/D Data Registers A to D (ADDRA to ADDRD)	416
16.3.2	A/D Control/Status Register (ADCSR)	417
16.3.3	A/D Control Register (ADCR)	418
16.4	Operation	419
16.4.1	Single Mode.....	419

16.4.2	Scan Mode	419
16.4.3	Input Sampling and A/D Conversion Time	421
16.4.4	External Trigger Input Timing	422
16.5	Interrupt Sources	423
16.6	A/D Conversion Accuracy Definitions	423
16.7	Usage Notes	425
16.7.1	Permissible Signal Source Impedance	425
16.7.2	Influences on Absolute Accuracy	425
16.7.3	Setting Range of Analog Power Supply and Other Pins	426
16.7.4	Notes on Board Design	426
16.7.5	Notes on Noise Countermeasures	426
16.7.6	Module Stop Mode Setting	427
Section 17 RAM		429
Section 18 ROM		431
18.1	Features	431
18.2	Mode Transitions	433
18.3	Block Configuration	436
18.4	Input/Output Pins	437
18.5	Register Descriptions	437
18.5.1	Flash Memory Control Register 1 (FLMCR1)	438
18.5.2	Flash Memory Control Register 2 (FLMCR2)	439
18.5.3	Erase Block Registers 1 and 2 (EBR1, EBR2)	440
18.6	Operating Modes	441
18.7	On-Board Programming Modes	441
18.7.1	Boot Mode	442
18.7.2	User Program Mode	445
18.8	Flash Memory Programming/Erasing	446
18.8.1	Program/Program-Verify	446
18.8.2	Erase/Erase-Verify	448
18.9	Program/Erase Protection	450
18.9.1	Hardware Protection	450
18.9.2	Software Protection	450
18.9.3	Error Protection	450
18.10	Interrupts during Flash Memory Programming/Erasing	451
18.11	Programmer Mode	452
18.12	Usage Notes	453
Section 19 Clock Pulse Generator		455
19.1	Oscillator	456
19.1.1	Connecting Crystal Resonator	456
19.1.2	External Clock Input Method	457

19.2	Duty Correction Circuit	459
19.3	Medium-Speed Clock Divider	459
19.4	Bus Master Clock Select Circuit.....	459
19.5	Subclock Input Circuit.....	460
19.6	Waveform Forming Circuit.....	460
19.7	Clock Select Circuit.....	461
19.8	Usage Notes	461
	19.8.1 Note on Resonator	461
	19.8.2 Notes on Board Design	461
Section 20 Power-Down Modes		463
20.1	Register Descriptions.....	463
	20.1.1 Standby Control Register (SBYCR)	464
	20.1.2 Low-Power Control Register (LPWRCR)	465
	20.1.3 Module Stop Control Registers H and L (MSTPCRH, MSTPCRL)	467
20.2	Mode Transitions and LSI States	468
20.3	Medium-Speed Mode	470
20.4	Sleep Mode	471
20.5	Software Standby Mode.....	471
20.6	Hardware Standby Mode	473
20.7	Watch Mode.....	474
20.8	Subsleep Mode.....	475
20.9	Subactive Mode	476
20.10	Module Stop Mode	477
20.11	Direct Transitions	477
20.12	Usage Notes	478
	20.12.1 I/O Port Status.....	478
	20.12.2 Current Consumption when Waiting for Oscillation Stabilization	478
Section 21 List of Registers.....		479
21.1	Register Addresses (Address Order).....	480
21.2	Register Bits.....	489
21.3	Register States in Each Operating Mode	497
21.4	Register Select Conditions.....	505
Section 22 Electrical Characteristics		513
22.1	Absolute Maximum Ratings	513
22.2	DC Characteristics	514
22.3	AC Characteristics	520
	22.3.1 Clock Timing.....	521
	22.3.2 Control Signal Timing	522
	22.3.3 Timing of On-Chip Peripheral Modules	523
22.4	A/D Conversion Characteristics	526

22.5	Flash Memory Characteristics	527
22.6	Usage Note.....	529
22.7	Timing Chart.....	529
22.7.1	Clock Timing	529
22.7.2	Control Signal Timing	531
22.7.3	On-Chip Peripheral Module Timing	532
Appendix		537
A.	I/O Port States in Each Processing State.....	537
B.	Product Codes	538
C.	Package Dimensions	539
Index		541

Figures

Section 1 Overview

Figure 1.1	Internal Block Diagram	2
Figure 1.2	Pin Arrangement.....	3

Section 2 CPU

Figure 2.1	Exception Vector Table (Normal Mode).....	17
Figure 2.2	Stack Structure in Normal Mode.....	17
Figure 2.3	Exception Vector Table (Advanced Mode).....	18
Figure 2.4	Stack Structure in Advanced Mode.....	19
Figure 2.5	Memory Map.....	20
Figure 2.6	CPU Internal Registers.....	21
Figure 2.7	Usage of General Registers.....	22
Figure 2.8	Stack.....	23
Figure 2.9	General Register Data Formats (1).....	26
Figure 2.9	General Register Data Formats (2).....	27
Figure 2.10	Memory Data Formats.....	28
Figure 2.11	Instruction Formats (Examples).....	39
Figure 2.12	Branch Address Specification in Memory Indirect Addressing Mode.....	43
Figure 2.13	State Transitions.....	47

Section 3 MCU Operating Modes

Figure 3.1	Address Map for H8S/2111B-B.....	57
Figure 3.2	Address Map for H8S/2111B-C.....	58

Section 4 Exception Handling

Figure 4.1	Reset Sequence (Mode 3).....	61
Figure 4.2	Stack Status after Exception Handling.....	64
Figure 4.3	Operation when SP Value is Odd.....	65

Section 5 Interrupt Controller

Figure 5.1	Block Diagram of Interrupt Controller.....	68
Figure 5.2	Relationship between Interrupts IRQ7 and IRQ6, Interrupts KIN15 to KIN0, Interrupts WUE7 to WUE0, and Registers KMIMR, KMIMRA, and WUEMRB.....	75
Figure 5.3	Block Diagram of Interrupts IRQ7 to IRQ0.....	76
Figure 5.4	Flowchart of Procedure up to Interrupt Acceptance in Interrupt Control Mode 0.....	81
Figure 5.5	State Transition in Interrupt Control Mode 1.....	82
Figure 5.6	Flowchart of Procedure Up to Interrupt Acceptance in Interrupt Control Mode 1.....	84
Figure 5.7	Interrupt Exception Handling.....	85
Figure 5.8	Address Break Block Diagram.....	87
Figure 5.9	Address Break Timing Example.....	89
Figure 5.10	Conflict between Interrupt Generation and Disabling.....	90

Section 8 8-Bit PWM Timer (PWM)

Figure 8.1	Block Diagram of PWM Timer.....	147
Figure 8.2	Example of Additional Pulse Timing (When Upper 4 Bits of PWDR = B'1000)	154
Figure 8.3	Example of PWM Setting.....	155
Figure 8.4	Example when PWM is Used as D/A Converter.....	155

Section 9 16-Bit Free-Running Timer (FRT)

Figure 9.1	Block Diagram of 16-Bit Free-Running Timer	158
Figure 9.2	Example of Pulse Output.....	169
Figure 9.3	Increment Timing with Internal Clock Source	170
Figure 9.4	Increment Timing with External Clock Source	170
Figure 9.5	Timing of Output Compare A Output	171
Figure 9.6	Clearing of FRC by Compare-Match A Signal	171
Figure 9.7	Input Capture Input Signal Timing (Usual Case).....	172
Figure 9.8	Input Capture Input Signal Timing (When ICRA to ICRD are Read)	172
Figure 9.9	Buffered Input Capture Timing.....	173
Figure 9.10	Buffered Input Capture Timing (BUFEA = 1).....	173
Figure 9.11	Timing of Input Capture Flag (ICFA, ICFB, ICFC, or ICFD) Setting.....	174
Figure 9.12	Timing of Output Compare Flag (OCFA or OCFB) Setting	174
Figure 9.13	Timing of Overflow Flag (OVF) Setting.....	175
Figure 9.14	OCRA Automatic Addition Timing	175
Figure 9.15	Timing of Input Capture Mask Signal Setting.....	176
Figure 9.16	Timing of Input Capture Mask Signal Clearing	176
Figure 9.17	FRC Write-Clear Conflict	177
Figure 9.18	FRC Write-Increment Conflict.....	178
Figure 9.19	Conflict between OCR Write and Compare-Match (When Automatic Addition Function is Not Used)	179
Figure 9.20	Conflict between OCRAR/OCRAF Write and Compare-Match (When Automatic Addition Function is Used)	179

Section 10 8-Bit Timer (TMR)

Figure 10.1	Block Diagram of 8-Bit Timer (TMR_0 and TMR_1).....	185
Figure 10.2	Block Diagram of 8-Bit Timer (TMR_Y and TMR_X).....	186
Figure 10.3	Block Diagram of 8-Bit Timer (TMR_B and TMR_A)	187
Figure 10.4	Pulse Output Example.....	206
Figure 10.5	Count Timing for Internal Clock Input	207
Figure 10.6	Count Timing for External Clock Input (Both Edges)	207
Figure 10.7	Timing of CMF Setting at Compare-Match	208
Figure 10.8	Timing of Toggled Timer Output by Compare-Match A Signal.....	208
Figure 10.9	Timing of Counter Clear by Compare-Match	208
Figure 10.10	Timing of Counter Clear by External Reset Input.....	209
Figure 10.11	Timing of OVF Flag Setting	209
Figure 10.12	Timing of Input Capture Operation.....	213

Figure 10.13	Timing of Input Capture Signal (Input capture signal is input during TICRR and TICRF read)	213
Figure 10.14	Conflict between TCNT Write and Clear	216
Figure 10.15	Conflict between TCNT Write and Count-Up	216
Figure 10.16	Conflict between TCOR Write and Compare-Match	217

Section 11 Watchdog Timer (WDT)

Figure 11.1	Block Diagram of WDT	222
Figure 11.2	Watchdog Timer Mode (RST/NMI = 1) Operation	228
Figure 11.3	Interval Timer Mode Operation	229
Figure 11.4	OVF Flag Set Timing	229
Figure 11.5	Output Timing of $\overline{\text{RESO}}$ signal	230
Figure 11.6	Writing to TCNT and TCSR (WDT_0)	231
Figure 11.7	Conflict between TCNT Write and Increment	232
Figure 11.8	Sample Circuit for Resetting System by $\overline{\text{RESO}}$ Signal	233

Section 12 Serial Communication Interface (SCI)

Figure 12.1	Block Diagram of SCI	236
Figure 12.2	Data Format in Asynchronous Communication (Example with 8-Bit Data, Parity, Two Stop Bits)	249
Figure 12.3	Receive Data Sampling Timing in Asynchronous Mode	251
Figure 12.4	Relation between Output Clock and Transmit Data Phase (Asynchronous Mode)	252
Figure 12.5	Sample SCI Initialization Flowchart	253
Figure 12.6	Example of SCI Transmit Operation in Asynchronous Mode (Example with 8-Bit Data, Parity, One Stop Bit)	254
Figure 12.7	Sample Serial Transmission Flowchart	255
Figure 12.8	Example of SCI Receive Operation in Asynchronous Mode (Example with 8-Bit Data, Parity, One Stop Bit)	256
Figure 12.9	Sample Serial Reception Flowchart (1)	257
Figure 12.9	Sample Serial Reception Flowchart (2)	258
Figure 12.10	Example of Communication Using Multiprocessor Format (Transmission of Data H'AA to Receiving Station A)	259
Figure 12.11	Sample Multiprocessor Serial Transmission Flowchart	260
Figure 12.12	Example of SCI Receive Operation (Example with 8-Bit Data, Multiprocessor Bit, One Stop Bit)	261
Figure 12.13	Sample Multiprocessor Serial Reception Flowchart (1)	262
Figure 12.13	Sample Multiprocessor Serial Reception Flowchart (2)	263
Figure 12.14	Data Format in Clocked Synchronous Communication (LSB-First)	264
Figure 12.15	Sample SCI Initialization Flowchart	265
Figure 12.16	Example of SCI Transmit Operation in Clocked Synchronous Mode	266
Figure 12.17	Sample Serial Transmission Flowchart	267
Figure 12.18	Example of SCI Receive Operation in Clocked Synchronous Mode	268
Figure 12.19	Sample Serial Reception Flowchart	269

Figure 12.20	Sample Flowchart of Simultaneous Serial Transmission and Reception	270
Figure 12.21	Sample Flowchart for Mode Transition during Transmission	274
Figure 12.22	Pin States during Transmission in Asynchronous Mode (Internal Clock)	274
Figure 12.23	Pin States during Transmission in Clocked Synchronous Mode (Internal Clock).....	275
Figure 12.24	Sample Flowchart for Mode Transition during Reception	275
Figure 12.25	Switching from SCK Pins to Port Pins.....	276
Figure 12.26	Prevention of Low Pulse Output at Switching from SCK Pins to Port Pins.....	276

Section 13 I²C Bus Interface (IIC)

Figure 13.1	Block Diagram of I ² C Bus Interface	278
Figure 13.2	I ² C Bus Interface Connections (Example: This LSI as Master)	279
Figure 13.3	I ² C Bus Data Format (I ² C Bus Format).....	307
Figure 13.4	I ² C Bus Data Format (Serial Format).....	307
Figure 13.5	I ² C Bus Timing.....	308
Figure 13.6	Sample Flowchart for IIC Initialization	309
Figure 13.7	Sample Flowchart for Operations in Master Transmit Mode.....	310
Figure 13.8	Example of Operation Timing in Master Transmit Mode (MLS = WAIT = 0)	312
Figure 13.9	Example of Stop Condition Issuance Operation Timing in Master Transmit Mode (MLS = WAIT = 0).....	313
Figure 13.10	Sample Flowchart for Operations in Master Receive Mode (HNDS = 1).....	314
Figure 13.11	Example of Operation Timing in Master Receive Mode (MLS = WAIT = 0, HNDS = 1).....	316
Figure 13.12	Example of Stop Condition Issuance Operation Timing in Master Receive Mode (MLS = WAIT = 0, HNDS = 1)	316
Figure 13.13	Sample Flowchart for Operations in Master Receive Mode (receiving multiple bytes) (WAIT = 1).....	317
Figure 13.14	Sample Flowchart for Operations in Master Receive Mode (receiving a single byte) (WAIT = 1)	318
Figure 13.15	Example of Master Receive Mode Operation Timing (MLS = ACKB = 0, WAIT = 1)	320
Figure 13.16	Example of Stop Condition Issuance Timing in Master Receive Mode (MLS = ACKB = 0, WAIT = 1)	321
Figure 13.17	Sample Flowchart for Operations in Slave Receive Mode (HNDS = 1).....	322
Figure 13.18	Example of Slave Receive Mode Operation Timing (1) (MLS = 0, HNDS = 1) ...	324
Figure 13.19	Example of Slave Receive Mode Operation Timing (2) (MLS = 0, HNDS = 1) ...	324
Figure 13.20	Sample Flowchart for Operations in Slave Receive Mode (HNDS = 0).....	325
Figure 13.21	Example of Slave Receive Mode Operation Timing (1) (MLS = ACKB = 0, HNDS = 0).....	327
Figure 13.22	Example of Slave Receive Mode Operation Timing (2) (MLS = ACKB = 0, HNDS = 0).....	327
Figure 13.23	Sample Flowchart for Slave Transmit Mode.....	328
Figure 13.24	Example of Slave Transmit Mode Operation Timing (MLS = 0)	330

Figure 13.25	IRIC Setting Timing and SCL Control (1)	331
Figure 13.26	IRIC Setting Timing and SCL Control (2)	332
Figure 13.27	IRIC Setting Timing and SCL Control (3)	333
Figure 13.28	Block Diagram of Noise Canceler	334
Figure 13.29	Notes on Reading Master Receive Data	340
Figure 13.30	Flowchart for Start Condition Issuance Instruction for Retransmission and Timing	341
Figure 13.31	Stop Condition Issuance Timing	342
Figure 13.32	IRIC Flag Clearing Timing when WAIT = 1	343
Figure 13.33	ICDR Read and ICCR Access Timing in Slave Transmit Mode	344
Figure 13.34	TRS Bit Set Timing in Slave Mode	345
Figure 13.35	Diagram of Erroneous Operation when Arbitration is Lost	347

Section 14 Keyboard Buffer Controller

Figure 14.1	Block Diagram of Keyboard Buffer Controller	349
Figure 14.2	Keyboard Buffer Controller Connection	350
Figure 14.3	Sample Receive Processing Flowchart	355
Figure 14.4	Receive Timing	356
Figure 14.5	Sample Transmit Processing Flowchart (1)	357
Figure 14.5	Sample Transmit Processing Flowchart (2)	358
Figure 14.6	Transmit Timing	358
Figure 14.7	Sample Receive Abort Processing Flowchart (1)	359
Figure 14.7	Sample Receive Abort Processing Flowchart (2)	360
Figure 14.8	Receive Abort and Transmit Start (Transmission/Reception Switchover) Timing	360
Figure 14.9	KCLKI and KDI Read Timing	361
Figure 14.10	KCLKO and KDO Write Timing	361
Figure 14.11	KBF Setting and KCLK Automatic I/O Inhibit Generation Timing	362
Figure 14.12	Receive Counter and KBBR Data Load Timing	363
Figure 14.13	Example of KCLK Input Fall Interrupt Operation	364
Figure 14.14	KBIOE Setting and KCLK Falling Edge Detection Timing	365

Section 15 Host Interface (LPC)

Figure 15.1	Block Diagram of LPC	370
Figure 15.2	Typical LFRAME Timing	400
Figure 15.3	Abort Mechanism	400
Figure 15.4	GA20 Output	401
Figure 15.5	Power-Down State Termination Timing	406
Figure 15.6	SERIRQ Timing	407
Figure 15.7	Clock Start Request Timing	409
Figure 15.8	HIRQ Flowchart (Example of Channel 1)	412

Section 16 A/D Converter	
Figure 16.1 Block Diagram of A/D Converter	414
Figure 16.2 Example of A/D Converter Operation (Scan Mode, Channels AN0 to AN2 Selected).....	420
Figure 16.3 A/D Conversion Timing	421
Figure 16.4 External Trigger Input Timing	422
Figure 16.5 A/D Conversion Accuracy Definitions	424
Figure 16.6 A/D Conversion Accuracy Definitions	424
Figure 16.7 Example of Analog Input Circuit	425
Figure 16.8 Example of Analog Input Protection Circuit.....	427
Figure 16.9 Equivalent Circuit of Analog Input Pin.....	427
Section 18 ROM	
Figure 18.1 Block Diagram of Flash Memory	432
Figure 18.2 Flash Memory State Transitions.....	433
Figure 18.3 Boot Mode.....	434
Figure 18.4 User Program Mode (Example)	435
Figure 18.5 Flash Memory Block Configuration.....	436
Figure 18.6 On-Chip RAM Area in Boot Mode.....	444
Figure 18.7 ID Code Area	444
Figure 18.8 Programming/Erasing Flowchart Example in User Program Mode.....	445
Figure 18.9 Program/Program-Verify Flowchart	447
Figure 18.10 Erase/Erase-Verify Flowchart	449
Figure 18.11 Memory Map in Programmer Mode.....	452
Section 19 Clock Pulse Generator	
Figure 19.1 Block Diagram of Clock Pulse Generator	455
Figure 19.2 Typical Connection to Crystal Resonator.....	456
Figure 19.3 Equivalent Circuit of Crystal Resonator.....	456
Figure 19.4 Example of External Clock Input	457
Figure 19.5 External Clock Input Timing	458
Figure 19.6 Timing of External Clock Output Stabilization Delay Time	459
Figure 19.7 Subclock Input Timing	460
Figure 19.8 Note on Board Design of Oscillator Circuit Section	461
Section 20 Power-Down Modes	
Figure 20.1 Mode Transition Diagram	468
Figure 20.2 Medium-Speed Mode Timing	470
Figure 20.3 Application Example in Software Standby Mode	472
Figure 20.4 Hardware Standby Mode Timing	473
Section 22 Electrical Characteristics	
Figure 22.1 Darlington Pair Drive Circuit (Example)	518
Figure 22.2 LED Drive Circuit (Example)	519
Figure 22.3 Output Load Circuit	520

Figure 22.4	Connection of VCL Capacitor.....	529
Figure 22.5	System Clock Timing.....	529
Figure 22.6	Oscillation Settling Timing.....	530
Figure 22.7	Oscillation Setting Timing (Exiting Software Standby Mode).....	530
Figure 22.8	Reset Input Timing.....	531
Figure 22.9	Interrupt Input Timing.....	531
Figure 22.10	I/O Port Input/Output Timing.....	532
Figure 22.11	FRT Input/Output Timing.....	532
Figure 22.12	FRT Clock Input Timing.....	532
Figure 22.13	8-Bit Timer Output Timing.....	533
Figure 22.14	8-Bit Timer Clock Input Timing.....	533
Figure 22.15	8-Bit Timer Reset Input Timing.....	533
Figure 22.16	PWM, PWMX Output Timing.....	533
Figure 22.17	SCK Clock Input Timing.....	534
Figure 22.18	SCI Input/Output Timing (Synchronous Mode).....	534
Figure 22.19	A/D Converter External Trigger Input Timing.....	534
Figure 22.20	WDT Output Timing ($\overline{\text{RESO}}$).....	534
Figure 22.21	Keyboard Buffer Controller Timing.....	535
Figure 22.22	I ² C Bus Interface Input/Output Timing.....	535
Figure 22.23	Host Interface (LPC) Timing.....	536
Figure 22.24	Tester Measurement Condition.....	536

Appendix

Figure C.1	Package Dimensions (TFP-144).....	539
------------	-----------------------------------	-----

Tables

Section 1 Overview

Table 1.1	Pin Functions in Each Operating Mode	4
Table 1.2	Pin Functions	9

Section 2 CPU

Table 2.1	Instruction Classification	29
Table 2.2	Operation Notation	30
Table 2.3	Data Transfer Instructions	31
Table 2.4	Arithmetic Operations Instructions (1)	32
Table 2.4	Arithmetic Operations Instructions (2)	33
Table 2.5	Logic Operations Instructions	34
Table 2.6	Shift Instructions	34
Table 2.7	Bit Manipulation Instructions (1)	35
Table 2.7	Bit Manipulation Instructions (2)	36
Table 2.8	Branch Instructions	37
Table 2.9	System Control Instructions	38
Table 2.10	Block Data Transfer Instructions	38
Table 2.11	Addressing Modes	40
Table 2.12	Absolute Address Access Ranges	41
Table 2.13	Effective Address Calculation (1)	44
Table 2.13	Effective Address Calculation (2)	45

Section 3 MCU Operating Modes

Table 3.1	MCU Operating Mode Selection	51
-----------	------------------------------------	----

Section 4 Exception Handling

Table 4.1	Exception Types and Priority	59
Table 4.2	Exception Handling Vector Table	60
Table 4.3	Status of CCR after Trap Instruction Exception Handling	63

Section 5 Interrupt Controller

Table 5.1	Pin Configuration	68
Table 5.2	Correspondence between Interrupt Source and ICR	70
Table 5.3	Interrupt Sources, Vector Addresses, and Interrupt Priorities	78
Table 5.4	Interrupt Control Modes	80
Table 5.5	Interrupt Response Times	86
Table 5.6	Number of States in Interrupt Handling Routine Execution Status	86

Section 7 I/O Ports

Table 7.1	Port Functions	96
Table 7.2	Input Pull-Up MOS States (Port 1)	102
Table 7.3	Input Pull-Up MOS States (Port 2)	104

Table 7.4	Input Pull-Up MOS States (Port 3).....	106
Table 7.5	Input Pull-Up MOS States (Port 6).....	116
Table 7.6	Input Pull-Up MOS States (Port A).....	128
Table 7.7	Input Pull-Up MOS States (Port B).....	131
Table 7.8	Input Pull-Up MOS States (Port C and port D).....	135
Table 7.9	Input Pull-Up MOS States (Port E and port F).....	141

Section 8 8-Bit PWM Timer (PWM)

Table 8.1	Pin Configuration.....	148
Table 8.2	Internal Clock Selection.....	150
Table 8.3	Resolution, PWM Conversion Period, and Carrier Frequency when $\phi = 10$ MHz.....	150
Table 8.4	Duty Cycle of Basic Pulse.....	153
Table 8.5	Position of Pulses Added to Basic Pulses.....	154

Section 9 16-Bit Free-Running Timer (FRT)

Table 9.1	Pin Configuration.....	159
Table 9.2	FRT Interrupt Sources.....	177
Table 9.3	Switching of Internal Clock and FRC Operation.....	180

Section 10 8-Bit Timer (TMR)

Table 10.1	TMR Function.....	184
Table 10.2	Pin Configuration.....	188
Table 10.3	Clock Input to TCNT and Count Condition (1).....	193
Table 10.3	Clock Input to TCNT and Count Condition (2).....	194
Table 10.3	Clock Input to TCNT and Count Condition (3).....	195
Table 10.4	Registers Accessible by TMR_X/TMR_Y.....	204
Table 10.5	Input Capture Signal Selection.....	214
Table 10.6	Input Capture Signal Selection.....	214
Table 10.7	Interrupt Sources of 8-Bit Timers TMR_0, TMR_1, TMR_Y, TMR_X TMR_B, and TMR_A.....	215
Table 10.8	Timer Output Priorities.....	217
Table 10.9	Switching of Internal Clocks and TCNT Operation.....	218

Section 11 Watchdog Timer (WDT)

Table 11.1	Pin Configuration.....	223
Table 11.2	WDT Interrupt Source.....	230

Section 12 Serial Communication Interface (SCI)

Table 12.1	Pin Configuration.....	236
Table 12.2	Relationships between N Setting in BRR and Bit Rate B.....	244
Table 12.3	BRR Settings for Various Bit Rates (Asynchronous Mode) (1).....	245
Table 12.3	BRR Settings for Various Bit Rates (Asynchronous Mode) (2).....	246
Table 12.4	Maximum Bit Rate for Each Frequency (Asynchronous Mode).....	247
Table 12.5	Maximum Bit Rate with External Clock Input (Asynchronous Mode).....	247
Table 12.6	BRR Settings for Various Bit Rates (Clocked Synchronous Mode).....	248

Table 12.7	Maximum Bit Rate with External Clock Input (Clocked Synchronous Mode)	248
Table 12.8	Serial Transfer Formats (Asynchronous Mode).....	250
Table 12.9	SSR Status Flags and Receive Data Handling.....	257
Table 12.10	SCI Interrupt Sources.....	271
Section 13 I2C Bus Interface (IIC)		
Table 13.1	Pin Configuration.....	280
Table 13.2	Communication Format	285
Table 13.3	I ² C Transfer Rate	288
Table 13.4	Flags and Transfer States (Master Mode).....	294
Table 13.5	Flags and Transfer States (Slave Mode)	295
Table 13.5	Flags and Transfer States (Slave Mode) (cont).....	296
Table 13.6	I ² C Bus Data Format Symbols.....	308
Table 13.7	IIC Interrupt Sources	336
Table 13.8	I ² C Bus Timing (SCL and SDA Outputs).....	337
Table 13.9	Permissible SCL Rise Time (t _{sr}) Values	338
Table 13.10	I ² C Bus Timing (with Maximum Influence of t _{sr} /t _{sf}).....	339
Section 14 Keyboard Buffer Controller		
Table 14.1	Pin Configuration.....	350
Section 15 Host Interface (LPC)		
Table 15.1	Pin Configuration.....	371
Table 15.2	Register Selection	382
Table 15.3	GA20 (P81) Set/Clear Timing	401
Table 15.4	Fast A20 Gate Output Signals.....	402
Table 15.5	Scope of Host Interface Pin Shutdown	404
Table 15.6	Scope of Initialization in Each Host Interface Mode	405
Table 15.7	Receive Complete Interrupts and Error Interrupt.....	410
Table 15.8	HIRQ Setting and Clearing Conditions	411
Section 16 A/D Converter		
Table 16.1	Pin Configuration.....	415
Table 16.2	Analog Input Channels and Corresponding ADDR Registers	416
Table 16.3	A/D Conversion Time (Single Mode).....	422
Section 18 ROM		
Table 18.1	Differences between Boot Mode and User Program Mode	433
Table 18.2	Pin Configuration.....	437
Table 18.3	Operating Modes and ROM.....	441
Table 18.4	On-Board Programming Mode Settings	441
Table 18.5	Boot Mode Operation	443
Table 18.6	System Clock Frequencies for which Automatic Adjustment of LSI Bit Rate is Possible.....	444

Section 19 Clock Pulse Generator

Table 19.1	Damping Resistance Values	456
Table 19.2	Crystal Resonator Parameters	456
Table 19.3	External Clock Input Conditions	458
Table 19.4	External Clock Output Stabilization Delay Time	458
Table 19.5	Subclock Input Conditions.....	460

Section 20 Power-Down Modes

Table 20.1	Operating Frequency and Wait Time.....	465
Table 20.2	LSI Internal States in Each Operating Mode	469

Section 22 Electrical Characteristics

Table 22.1	Absolute Maximum Ratings	513
Table 22.2	DC Characteristics (1)	514
Table 22.2	DC Characteristics (2)	516
Table 22.2	DC Characteristics (3) When LPC Function is Used.....	517
Table 22.3	Permissible Output Currents.....	518
Table 22.4	Bus Drive Characteristics	519
Table 22.5	Clock Timing.....	521
Table 22.6	Control Signal Timing	522
Table 22.7	Timing of On-Chip Peripheral Modules (1)	523
Table 22.8	Keyboard Buffer Controller Timing	524
Table 22.9	I ² C Bus Timing.....	525
Table 22.10	LPC Module Timing.....	526
Table 22.11	A/D Conversion Characteristics (AN5 to AN0 Input: 134/266-State Conversion).....	526
Table 22.12	Flash Memory Characteristics	527

Appendix

Table A.1	I/O Port States in Each Processing State.....	537
-----------	-----------------------------------------------	-----

Section 1 Overview

1.1 Features

- High-speed H8S/2000 central processing unit with an internal 16-bit architecture
Upward-compatible with H8/300 and H8/300H CPUs on an object level
Sixteen 16-bit general registers
65 basic instructions
- Various peripheral functions
8-bit PWM timer (PWM)
16-bit free-running timer (FRT)
8-bit timer (TMR)
Watchdog timer (WDT)
Asynchronous or clocked synchronous serial communication interface (SCI)
I²C bus interface (IIC)
Keyboard buffer controller
Host interface (LPC)
10-bit A/D converter
Clock pulse generator
- On-chip memory

ROM	Model	ROM	RAM	Remarks
F-ZTAT Version	HD64F2111BVB*	64 Kbytes	2 Kbytes	
	HD64F2111BVC*	64 Kbytes	3 Kbytes	

Note: * 3-V version product

- General I/O ports
I/O pins: 114
Input-only pins: 8
- Supports various power-down states
- Compact package

Product	Package	Code	Body Size	Pin Pitch
H8S/2111B	TQFP-144	TFP-144	18.0 × 18.0 mm	0.4 mm

1.2 Internal Block Diagram

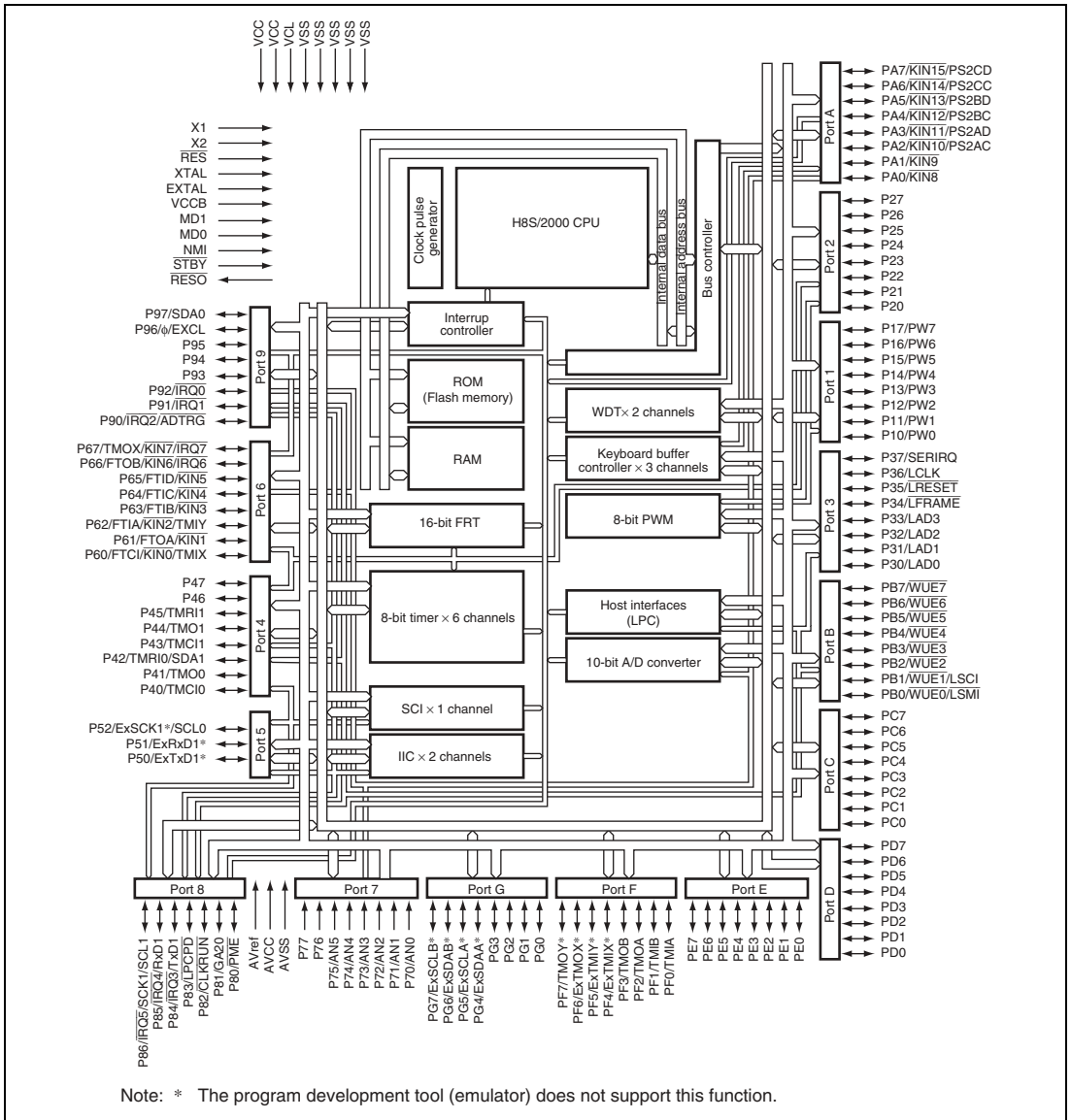

Figure 1.1 Internal Block Diagram

1.3 Pin Description

1.3.1 Pin Arrangement

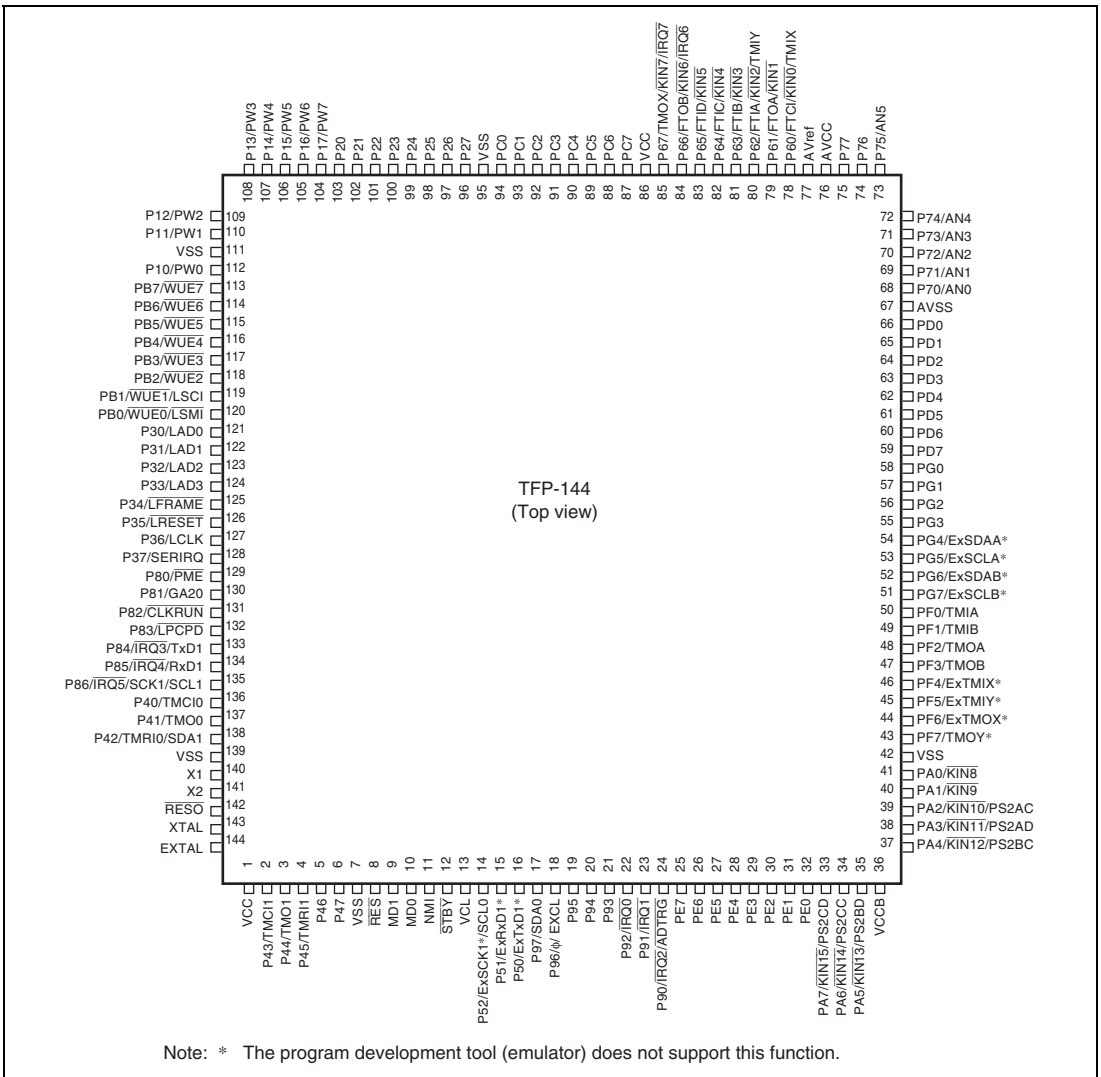

Figure 1.2 Pin Arrangement

1.3.2 Pin Functions in Each Operating Mode

Table 1.1 Pin Functions in Each Operating Mode

Pin No.	Pin Name	
	Single-Chip Modes	Flash Memory
TFP-144	Mode 2, Mode 3 (EXPE = 0)	Programmer Mode
1	VCC	VCC
2	P43/TMCI1	NC
3	P44/TMO1	NC
4	P45/TMRI1	NC
5	P46	NC
6	P47	NC
7	VSS	VSS
8	$\overline{\text{RES}}$	$\overline{\text{RES}}$
9	MD1	VSS
10	MD0	VSS
11	NMI	FA9
12	$\overline{\text{STBY}}$	VCC
13	VCL	VCC
14 (N)	P52/ExSCK1*/SCL0	FA18
15	P51/ExRxD1*	FA17
16	P50/ExTxD1*	NC
17 (N)	P97/SDA0	VCC
18	P96/ ϕ /EXCL	NC
19	P95	FA16
20	P94	FA15
21	P93	$\overline{\text{WE}}$
22	P92/ $\overline{\text{IRQ0}}$	VSS
23	P91/ $\overline{\text{IRQ1}}$	VCC
24	P90/ $\overline{\text{IRQ2}}$ /ADTRG	VCC
25	PE7	NC
26	PE6	NC
27	PE5	NC
28	PE4	NC
29	PE3	NC
30	PE2	NC

Pin Name		
Pin No.	Single-Chip Modes	Flash Memory
TFP-144	Mode 2, Mode 3 (EXPE = 0)	Programmer Mode
31	PE1	NC
32	PE0	NC
33 (B)	PA7/ $\overline{\text{KIN15}}$ /PS2CD	NC
34 (B)	PA6/ $\overline{\text{KIN14}}$ /PS2CC	NC
35 (B)	PA5/ $\overline{\text{KIN13}}$ /PS2BD	NC
36	VCCB	VCC
37 (B)	PA4/ $\overline{\text{KIN12}}$ /PS2BC	NC
38 (B)	PA3/ $\overline{\text{KIN11}}$ /PS2AD	NC
39 (B)	PA2/ $\overline{\text{KIN10}}$ /PS2AC	NC
40 (B)	PA1/ $\overline{\text{KIN9}}$	NC
41 (B)	PA0/ $\overline{\text{KIN8}}$	NC
42	VSS	VSS
43	PF7/TMOY*	NC
44	PF6/ExTMOX*	NC
45	PF5/ExTMIY*	NC
46	PF4/ExTMIX*	NC
47	PF3/TMOB	NC
48	PF2/TMOA	NC
49	PF1/TMIB	NC
50	PF0/TMIA	NC
51 (N)	PG7/ExSCLB*	NC
52 (N)	PG6/ExSDAB*	NC
53 (N)	PG5/ExSCLA*	NC
54 (N)	PG4/ExSDAA*	NC
55 (N)	PG3	NC
56 (N)	PG2	NC
57 (N)	PG1	NC
58 (N)	PG0	NC
59	PD7	NC
60	PD6	NC

Pin Name

Pin No.	Single-Chip Modes	Flash Memory
TFP-144	Mode 2, Mode 3 (EXPE = 0)	Programmer Mode
61	PD5	NC
62	PD4	NC
63	PD3	NC
64	PD2	NC
65	PD1	NC
66	PD0	NC
67	AVSS	VSS
68	P70/AN0	NC
69	P71/AN1	NC
70	P72/AN2	NC
71	P73/AN3	NC
72	P74/AN4	NC
73	P75/AN5	NC
74	P76	NC
75	P77	NC
76	AVCC	VCC
77	AVref	VCC
78	P60/FTCI/ $\overline{\text{KIN0}}$ /TMIX	NC
79	P61/FTOA/ $\overline{\text{KIN1}}$	NC
80	P62/FTIA/ $\overline{\text{KIN2}}$ /TMIY	NC
81	P63/FTIB/ $\overline{\text{KIN3}}$	NC
82	P64/FTIC/ $\overline{\text{KIN4}}$	NC
83	P65/FTID/ $\overline{\text{KIN5}}$	NC
84	P66/FTOB/ $\overline{\text{KIN6}}$ / $\overline{\text{IRQ6}}$	NC
85	P67/TMOX/ $\overline{\text{KIN7}}$ / $\overline{\text{IRQ7}}$	VSS
86	VCC	VCC
87	PC7	NC
88	PC6	NC
89	PC5	NC
90	PC4	NC

Pin No.	Pin Name	
	Single-Chip Modes	Flash Memory
TFP-144	Mode 2, Mode 3 (EXPE = 0)	Programmer Mode
91	PC3	NC
92	PC2	NC
93	PC1	NC
94	PC0	NC
95	VSS	VSS
96	P27	\overline{CE}
97	P26	FA14
98	P25	FA13
99	P24	FA12
100	P23	FA11
101	P22	FA10
102	P21	\overline{OE}
103	P20	FA8
104	P17/PW7	FA7
105	P16/PW6	FA6
106	P15/PW5	FA5
107	P14/PW4	FA4
108	P13/PW3	FA3
109	P12/PW2	FA2
110	P11/PW1	FA1
111	VSS	VSS
112	P10/PW0	FA0
113	$\overline{PB7/WUE7}$	NC
114	$\overline{PB6/WUE6}$	NC
115	$\overline{PB5/WUE5}$	NC
116	$\overline{PB4/WUE4}$	NC
117	$\overline{PB3/WUE3}$	NC
118	$\overline{PB2/WUE2}$	NC
119	$\overline{PB1/WUE1/LSCI}$	NC
120	$\overline{PB0/WUE0/LSMI}$	NC

Pin Name

Pin No.	Single-Chip Modes	Flash Memory
TFP-144	Mode 2, Mode 3 (EXPE = 0)	Programmer Mode
121	P30/LAD0	FO0
122	P31/LAD1	FO1
123	P32/LAD2	FO2
124	P33/LAD3	FO3
125	P34/ $\overline{\text{LFRAME}}$	FO4
126	P35/ $\overline{\text{LRESET}}$	FO5
127	P36/LCLK	FO6
128	P37/SERIRQ	FO7
129	P80/ $\overline{\text{PME}}$	NC
130	P81/GA20	NC
131	P82/ $\overline{\text{CLKRUN}}$	NC
132	P83/ $\overline{\text{LPCPD}}$	NC
133	P84/ $\overline{\text{IRQ3}}/\text{TxD1}$	NC
134	P85/ $\overline{\text{IRQ4}}/\text{RxD1}$	NC
135 (N)	P86/ $\overline{\text{IRQ5}}/\text{SCK1}/\text{SCL1}$	NC
136	P40/TMCIO	NC
137	P41/TMO0	NC
138 (N)	P42/TMRI0/SDA1	NC
139	VSS	VSS
140	X1	NC
141	X2	NC
142	$\overline{\text{RES0}}$	NC
143	XTAL	XTAL
144	EXTAL	EXTAL

Note: The (B) in Pin No. means the VCCB drive and the (N) in Pin No. means the NMOS push-pull/open-drain drive.

* The program development tool (emulator) does not support this function.

1.3.3 Pin Functions

Table 1.2 Pin Functions

Type	Symbol	Pin No.		Name and Function
		TFP-144	I/O	
Power	VCC	1, 86	Input	Power supply pin. Connect the pin to the system power supply.
	VCL	13	Input	Power supply pin. Connect the pin to VCC.
	VCCB	36	Input	The power supply for the port A input/output buffer.
	VSS	7, 42, 95, 111, 139	Input	Ground pin. Connect to the system power supply (0 V).
Clock	XTAL	143	Input	Pins for connection to crystal resonators. The EXTAL pin can also input an external clock. See section 19, Clock Pulse Generator, for typical connection diagrams.
	EXTAL	144	Input	
	ϕ	18	Output	Supplies the system clock to external devices.
	EXCL	18	Input	Input a 32.768 kHz external subclock.
	X1	140	Input	Leave open.
	X2	141	Input	Leave open.
Operating mode control	MD1	9	Input	These pins set the operating mode. These pins should not be changed while the MCU is operating.
	MD0	10		
System control	$\overline{\text{RES}}$	8	Input	Reset pin. When this pin becomes low, the chip is reset.
	$\overline{\text{RESO}}$	142	Output	Outputs reset signal to external device.
	$\overline{\text{STBY}}$	12	Input	When this pin is driven low, a transition is made to hardware standby mode.
Interrupt signals	NMI	11	Input	Input pin for a nonmaskable interrupt request.
	$\overline{\text{IRQ0}}$ to $\overline{\text{IRQ7}}$	22 to 24, 133 to 135, 84, 85	Input	These pins request a maskable interrupt.

Type	Symbol	Pin No.		Name and Function
		TFP-144	I/O	
16-bit free-running timer (FRT)	FTCI	78	Input	The counter clock input pin.
	FTOA	79	Output	The output compare A output pin.
	FTOB	84	Output	The output compare B output pin.
	FTIA	80	Input	The input capture A input pin.
	FTIB	81	Input	The input capture B input pin.
	FTIC	82	Input	The input capture C input pin.
	FTID	83	Input	The input capture D input pin.
8-bit timer (TMR_0, TMR_1, TMR_X, TMR_Y, TMR_A, TMR_B)	TMO0	137	Output	The waveform output pins for the output compare function.
	TMO1	3		
	TMOX	85		
	TMOY*	43		
	TMOA	48		
	TMOB	47		
	ExTMOX*	44		
	TMCI0	136	Input	Input pins for the external clock input to counters.
	TMCI1	2		
TMRI0	138	Input	The counter reset input pins.	
TMRI1	4			
8-bit timer (TMR_X, TMR_Y, TMR_A, TMR_B)	TMIX	78	Input	The counter event input and counter reset input pins.
	TMIY	80		
	TMIA	50		
	TMIB	49		
	ExTMIX*	46		
	ExTMIY*	45		
8-bit PWM timer (PWM)	PW7 to PW0	104 to 110, 112	Output	PWM timer pulse output pins.
Serial communication interface (SCI_1)	TxD1	133	Output	Transmit data output pins.
	ExTxD1*	16		
	RxD1	134	Input	Receive data input pins.
	ExRxD1*	15		
	SCK1	135	Input/ Output	Clock input/output pins. The output type is NMOS push-pull.
	ExSCK1*	14		
Keyboard buffer controller	PS2AC	39	Input/ Output	Keyboard buffer controller synchronization clock input/output pins.
	PS2BC	37		
	PS2CC	34		
	PS2AD	38	Input/ Output	Keyboard buffer controller data input/output pins.
	PS2BD	35		
	PS2CD	33		

Type	Symbol	Pin No.		Name and Function
		TFP-144	I/O	
Host interface (LPC)	LAD3 to LAD0	124 to 121	Input/Output	LPC command, address, and data input/output pins.
	$\overline{\text{LFRAME}}$	125	Input	Input pin that indicates the start of an LPC cycle or forced termination of an abnormal LPC cycle.
	$\overline{\text{LRESET}}$	126	Input	Input pin that indicates an LPC reset.
	LCLK	127	Input	The LPC clock input pin.
	SERIRQ	128	Input/Output	Input/output pin for LPC serialized host interrupts (HIRQ1, SMI, HIRQ6, HIRQ9 to HIRQ12).
	LSCI, $\overline{\text{LSMI}}$, $\overline{\text{PME}}$	119, 120, 129	Input/Output	LPC auxiliary output pins. Functionally, they are general I/O ports.
	GA20	130	Input/Output	A20 gate control signal output pin. Output state monitoring input is possible.
	$\overline{\text{CLKRUN}}$	131	Input/Output	Input/output pin that requests the start of LCLK operation when LCLK is stopped.
	$\overline{\text{LPCPD}}$	132	Input	Input pin that controls LPC module shutdown.
Keyboard buffer controller	$\overline{\text{KIN0}}$ to $\overline{\text{KIN15}}$	78 to 85, 41 to 37, 35 to 33	Input	Matrix keyboard input pins. $\overline{\text{KIN0}}$ to $\overline{\text{KIN15}}$ are used as key-scan inputs, and P10 to P17 and P20 to P27 are used as key-scan outputs. This allows a maximum 16-output × 16-input, 256-key matrix to be configured.
	$\overline{\text{WUE0}}$ to $\overline{\text{WUE7}}$	120 to 113	Input	Wakeup event input pins. These pins allow the same kind of wakeup as key-wakeup from various sources.
A/D converter	AN5 to AN0	73 to 68	Input	Analog input pins.
	ADTRG	24	Input	Pin for input of an external trigger to start A/D conversion.
	AVCC	76	Input	The analog power supply pin for the A/D converter. When the A/D is not used, this pin should be connected to the system power supply (+3 V).
	AVref	77	Input	The reference power supply pin for the A/D converter and. When the A/D is not used, this pin should be connected to the system power supply (+3 V).
	AVSS	67	Input	The ground pin for the A/D converter. This pin should be connected to the system power supply (0 V).

Type	Symbol	Pin No.		Name and Function	
		TFP-144	I/O		
I ² C bus interface (IIC)	SCL0	14	Input/	I ² C clock I/O pins. The output type is NMOS open-drain output.	
	SCL1	135	Output		
	ExSCLA*	53			
	ExSCLB*	51			
	SDA0	17	Input/		I ² C data I/O pins. The output type is NMOS open-drain output.
	SDA1	138	Output		
ExSDAA*	54				
ExSDAB*	52				
I/O ports	P17 to P10	104 to 110, 112	Input/Output	Eight input/output pins.	
	P27 to P20	96 to 103	Input/Output	Eight input/output pins.	
	P37 to P30	128 to 121	Input/Output	Eight input/output pins.	
	P47 to P40	6 to 2, 138 to 136	Input/Output	Eight input/output pins. (The output type of P42 is NMOS push-pull.)	
	P52 to P50	14 to 16	Input/Output	Three input/output pins. (The output type of P52 is NMOS push-pull.)	
	P67 to P60	85 to 78	Input/Output	Eight input/output pins.	
	P77 to P70	75 to 68	Input	Eight input pins.	
	P86 to P80	135 to 129	Input/Output	Seven input/output pins. (The output type of P86 is NMOS push-pull.)	
	P97 to P90	17 to 24	Input/Output	Eight input/output pins. (The output type of P97 is NMOS push-pull.)	
	PA7 to PA0	33 to 35, 37 to 41	Input/Output	Eight input/output pins.	
	PB7 to PB0	113 to 120	Input/Output	Eight input/output pins.	
	PC7 to PC0	87 to 94	Input/Output	Eight input/output pins.	
	PD7 to PD0	59 to 66	Input/Output	Eight input/output pins.	
	PE7 to PE0	25 to 32	Input/Output	Eight input/output pins.	
	PF7 to PF0	43 to 50	Input/Output	Eight input/output pins.	
	PG7 to PG0	51 to 58	Input/Output	Eight input/output pins. (The output type of PG7 to PG0 is NMOS push-pull.)	

Note: * The program development tool (emulator) does not support this function.

Section 2 CPU

The H8S/2000 CPU is a high-speed central processing unit with an internal 32-bit architecture that is upward-compatible with the H8/300 and H8/300H CPUs. The H8S/2000 CPU has sixteen 16-bit general registers, can address a 16-Mbyte linear address space, and is ideal for realtime control.

This section describes the H8S/2000 CPU. The usable modes and address spaces differ depending on the product. For details on each product, refer to section 3, MCU Operating Modes.

2.1 Features

- Upward-compatibility with H8/300 and H8/300H CPUs
Can execute H8/300 CPU and H8/300H CPU object programs
- General-register architecture
Sixteen 16-bit general registers also usable as sixteen 8-bit registers or eight 32-bit registers
- Sixty-five basic instructions
8/16/32-bit arithmetic and logic instructions
Multiply and divide instructions
Powerful bit-manipulation instructions
- Eight addressing modes
Register direct [Rn]
Register indirect [@ERn]
Register indirect with displacement [@(d:16,ERn) or @(d:32,ERn)]
Register indirect with post-increment or pre-decrement [@ERn+ or @-ERn]
Absolute address [@aa:8, @aa:16, @aa:24, or @aa:32]
Immediate [#xx:8, #xx:16, or #xx:32]
Program-counter relative [@(d:8,PC) or @(d:16,PC)]
Memory indirect [@@aa:8]
- 16-Mbyte address space
Program: 16 Mbytes
Data: 16 Mbytes
- High-speed operation
All frequently-used instructions are executed in one or two states
8/16/32-bit register-register add/subtract: 1 state
8 × 8-bit register-register multiply: 12 states (MULXU.B), 13 states (MULXS.B)
16 ÷ 8-bit register-register divide: 12 states (DIVXU.B)
16 × 16-bit register-register multiply: 20 states (MULXU.W), 21 states (MULXS.W)
32 ÷ 16-bit register-register divide: 20 states (DIVXU.W)

- Two CPU operating modes
 - Normal mode
 - Advanced mode
- Power-down state
 - Transition to power-down state by SLEEP instruction
 - Selectable CPU clock speed

2.1.1 Differences between H8S/2600 CPU and H8S/2000 CPU

The differences between the H8S/2600 CPU and the H8S/2000 CPU are as shown below.

- Register configuration
 - The MAC register is supported only by the H8S/2600 CPU.
- Basic instructions
 - The four instructions MAC, CLRMAC, LDMAC, and STMAC are supported only by the H8S/2600 CPU.
- The number of execution states of the MULXU and MULXS instructions

Instruction	Mnemonic	Execution States	
		H8S/2600	H8S/2000
MULXU	MULXU.B Rs, Rd	3	12
	MULXU.W Rs, ERd	4	20
MULXS	MULXS.B Rs, Rd	4	13
	MULXS.W Rs, ERd	5	21

In addition, there are differences in address space, CCR and EXR register functions, power-down modes, etc., depending on the model.

2.1.2 Differences from H8/300 CPU

In comparison to the H8/300 CPU, the H8S/2000 CPU has the following enhancements.

- More general registers and control registers
Eight 16-bit extended registers and one 8-bit control register have been added.
- Expanded address space
Normal mode supports the same 64-Kbyte address space as the H8/300 CPU.
Advanced mode supports a maximum 16-Mbyte address space.
- Enhanced addressing
The addressing modes have been enhanced to make effective use of the 16-Mbyte address space.
- Enhanced instructions
Addressing modes of bit-manipulation instructions have been enhanced.
Signed multiply and divide instructions have been added.
Two-bit shift and two-bit rotate instructions have been added.
Instructions for saving and restoring multiple registers have been added.
A test and set instruction has been added.
- Higher speed
Basic instructions are executed twice as fast.

2.1.3 Differences from H8/300H CPU

In comparison to the H8/300H CPU, the H8S/2000 CPU has the following enhancements.

- Additional control register
One 8-bit control register has been added.
- Enhanced instructions
Addressing modes of bit-manipulation instructions have been enhanced.
Two-bit shift and two-bit rotate instructions have been added.
Instructions for saving and restoring multiple registers have been added.
A test and set instruction has been added.
- Higher speed
Basic instructions are executed twice as fast.

2.2 CPU Operating Modes

The H8S/2000 CPU has two operating modes: normal and advanced. Normal mode supports a maximum 64-Kbyte address space. Advanced mode supports a maximum 16-Mbyte address space. The mode is selected by the LSI's mode pins.

2.2.1 Normal Mode

The exception vector table and stack have the same structure as in the H8/300 CPU in normal mode.

- Address space

Linear access to a maximum address space of 64 Kbytes is possible.

- Extended registers (En)

The extended registers (E0 to E7) can be used as 16-bit registers, or as the upper 16-bit segments of 32-bit registers.

When extended register En is used as a 16-bit register it can contain any value, even when the corresponding general register (Rn) is used as an address register. (If general register Rn is referenced in the register indirect addressing mode with pre-decrement (@-Rn) or post-increment (@Rn+) and a carry or borrow occurs, the value in the corresponding extended register (En) will be affected.)

- Instruction set

All instructions and addressing modes can be used. Only the lower 16 bits of effective addresses (EA) are valid.

- Exception vector table and memory indirect branch addresses

In normal mode, the top area starting at H'0000 is allocated to the exception vector table. One branch address is stored per 16 bits. The exception vector table in normal mode is shown in figure 2.1. For details on the exception vector table, see section 4, Exception Handling.

The memory indirect addressing mode (@@aa:8) employed in the JMP and JSR instructions uses an 8-bit absolute address included in the instruction code to specify a memory operand that contains a branch address. In normal mode, the operand is a 16-bit (word) operand, providing a 16-bit branch address. Branch addresses can be stored in the top area from H'0000 to H'00FF. Note that this area is also used for the exception vector table.

- Stack structure

In normal mode, when the program counter (PC) is pushed onto the stack in a subroutine call in normal mode, and the PC and condition-code register (CCR) are pushed onto the stack in exception handling, they are stored as shown in figure 2.2. The extended control register (EXR) is not pushed onto the stack. For details, see section 4, Exception Handling.

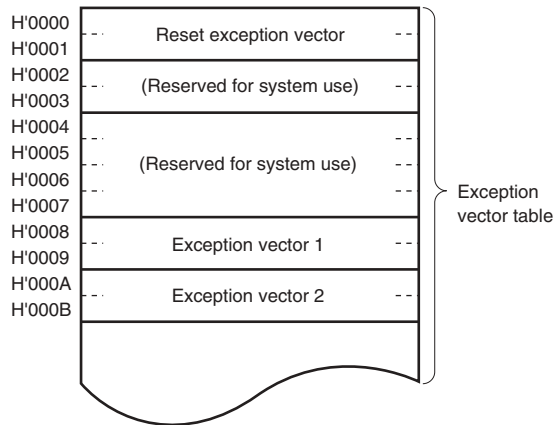
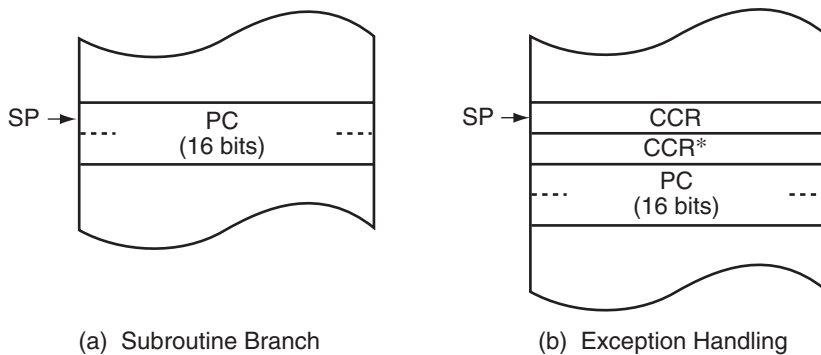

Figure 2.1 Exception Vector Table (Normal Mode)



Note: * Ignored when returning.

Figure 2.2 Stack Structure in Normal Mode

2.2.2 Advanced Mode

- Address space

Linear access to a maximum address space of 16 Mbytes is possible.

- Extended registers (En)

The extended registers (E0 to E7) can be used as 16-bit registers. They can also be used as the upper 16-bit segments of 32-bit registers or address registers.

- Instruction set

All instructions and addressing modes can be used.

- Exception vector table and memory indirect branch addresses

In advanced mode, the top area starting at H'00000000 is allocated to the exception vector table in 32-bit units. In each 32 bits, the upper 8 bits are ignored and a branch address is stored in the lower 24 bits (see figure 2.3). For details on the exception vector table, see section 4, Exception Handling.

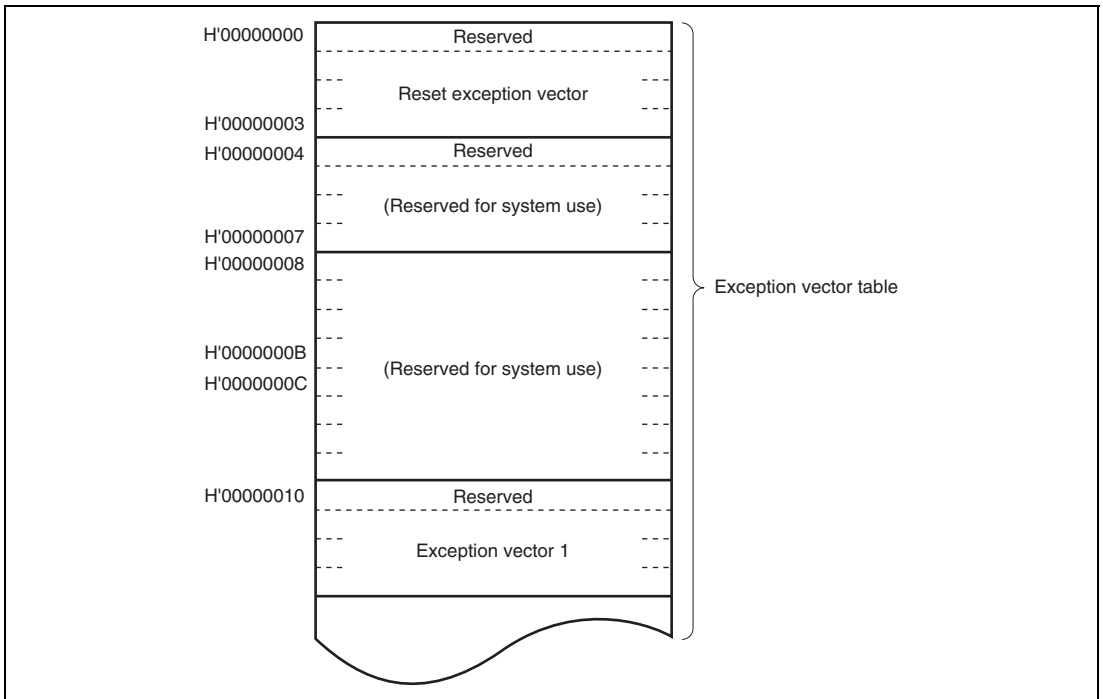

Figure 2.3 Exception Vector Table (Advanced Mode)

The memory indirect addressing mode (@@aa:8) employed in the JMP and JSR instructions uses an 8-bit absolute address included in the instruction code to specify a memory operand that contains a branch address. In advanced mode, the operand is a 32-bit longword operand, providing a 32-bit branch address. The upper 8 bits of these 32 bits are a reserved area that is regarded as H'00. Branch addresses can be stored in the area from H'00000000 to H'000000FF. Note that the top area of this range is also used for the exception vector table.

- Stack structure

In advanced mode, when the program counter (PC) is pushed onto the stack in a subroutine call, and the PC and condition-code register (CCR) are pushed onto the stack in exception handling, they are stored as shown in figure 2.4. The extended control register (EXR) is not pushed onto the stack. For details, see section 4, Exception Handling.

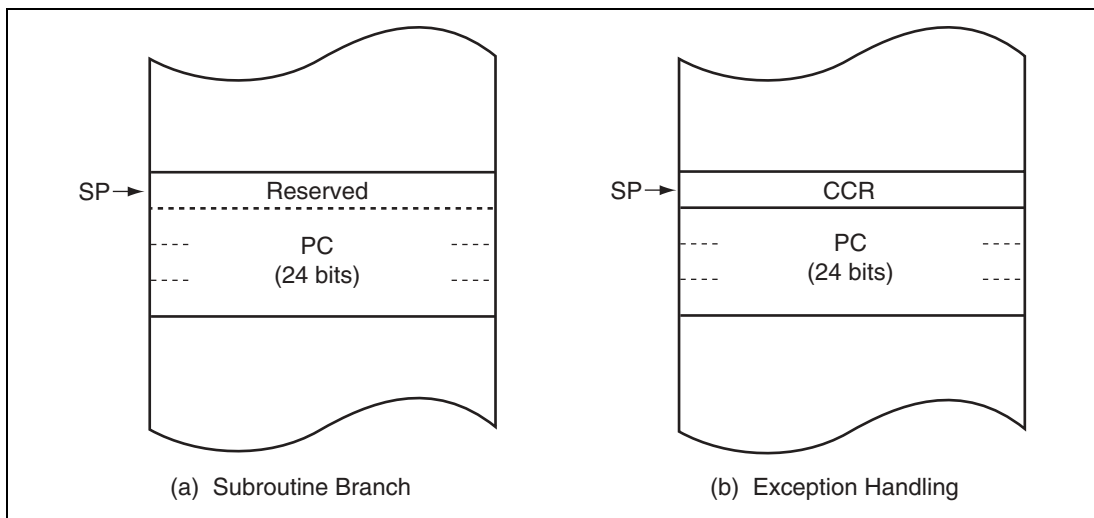

Figure 2.4 Stack Structure in Advanced Mode

2.3 Address Space

Figure 2.5 shows a memory map of the H8S/2000 CPU. The H8S/2000 CPU provides linear access to a maximum 64-Kbyte address space in normal mode, and a maximum 16-Mbyte (architecturally 4-Gbyte) address space in advanced mode. The usable modes and address spaces differ depending on the product. For details on each product, refer to section 3, MCU Operating Modes.

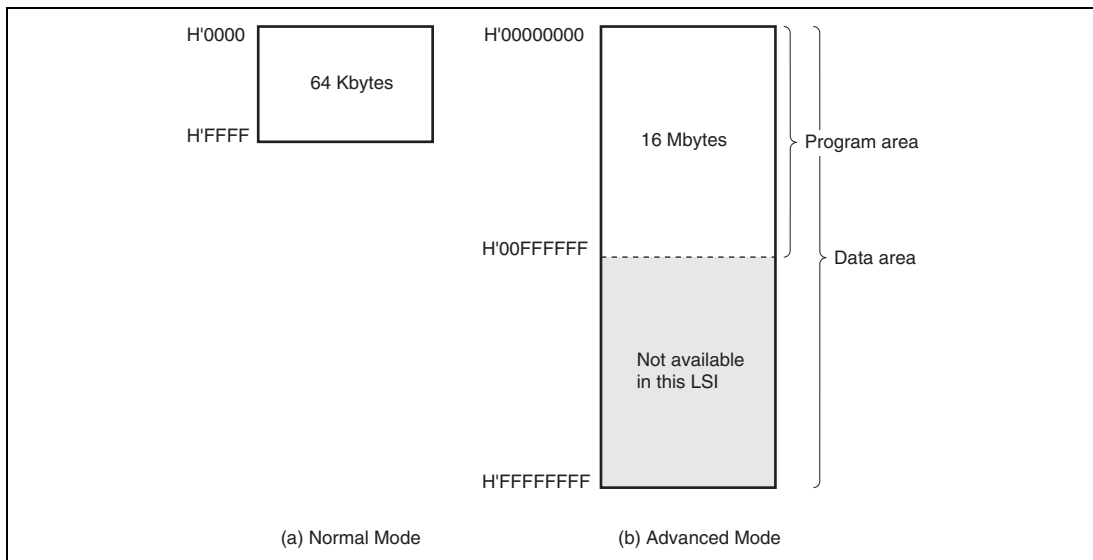

Figure 2.5 Memory Map

2.4 Register Configuration

The H8S/2000 CPU has the internal registers shown in figure 2.6. There are two types of registers: general registers and control registers. Control registers are a 24-bit program counter (PC), an 8-bit extended control register (EXR), and an 8-bit condition code register (CCR).

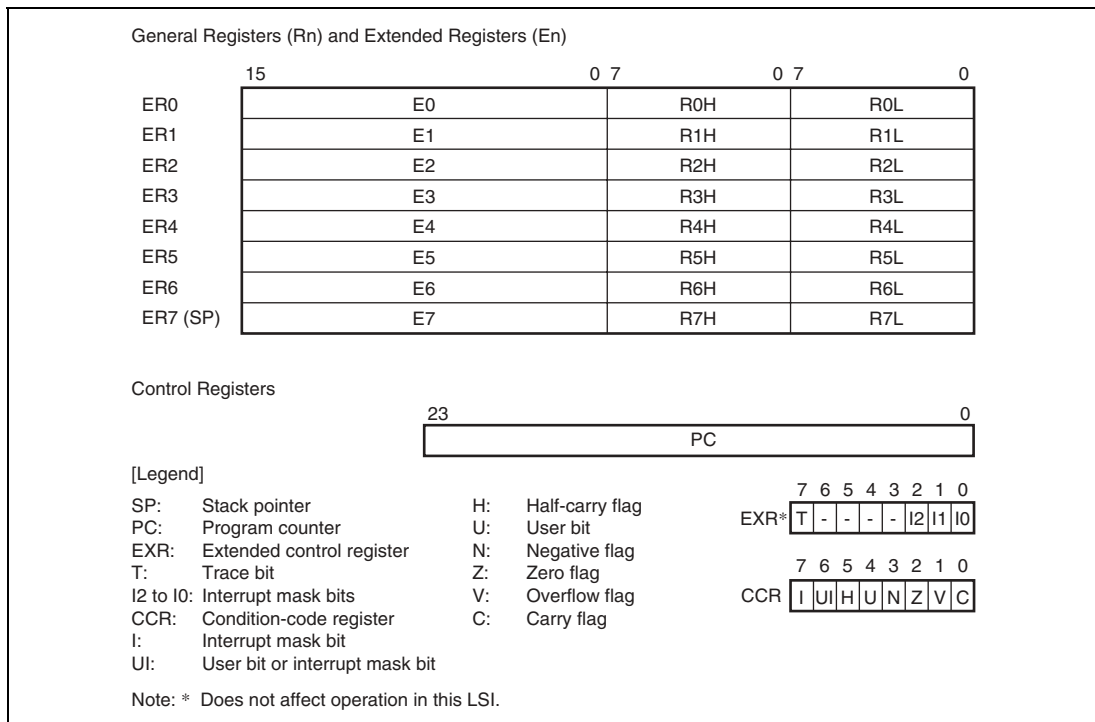

Figure 2.6 CPU Internal Registers

2.4.1 General Registers

The H8S/2000 CPU has eight 32-bit general registers. These general registers are all functionally alike and can be used as both address registers and data registers. When a general register is used as a data register, it can be accessed as a 32-bit, 16-bit, or 8-bit register. Figure 2.7 illustrates the usage of the general registers.

When the general registers are used as 32-bit registers or address registers, they are designated by the letters ER (ER0 to ER7).

When the general registers are used as 16-bit registers, the ER registers are divided into 16-bit general registers designated by the letters E (E0 to E7) and R (R0 to R7). These registers are functionally equivalent, providing a maximum sixteen 16-bit registers. The E registers (E0 to E7) are also referred to as extended registers.

When the general registers are used as 8-bit registers, the R registers are divided into 8-bit general registers designated by the letters RH (R0H to R7H) and RL (R0L to R7L). These registers are functionally equivalent, providing a maximum sixteen 8-bit registers.

The usage of each register can be selected independently.

General register ER7 has the function of the stack pointer (SP) in addition to its general-register function, and is used implicitly in exception handling and subroutine calls. Figure 2.8 shows the stack.

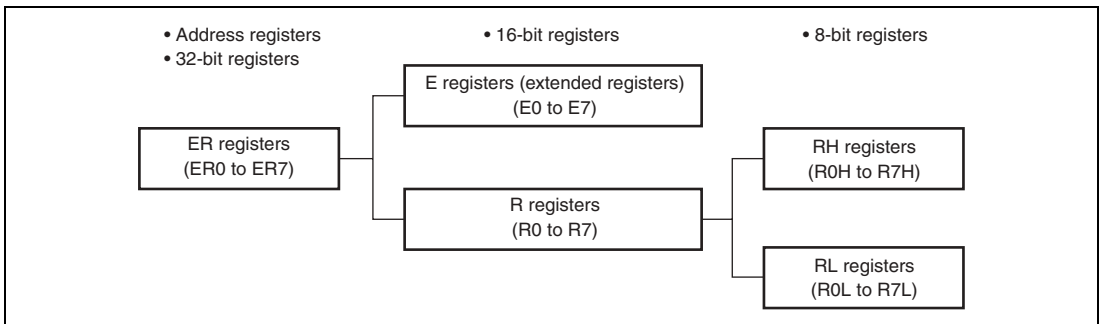

Figure 2.7 Usage of General Registers

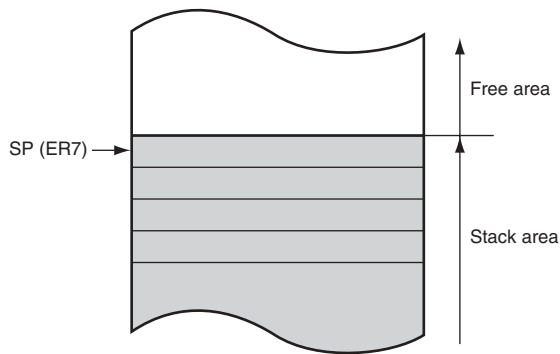

Figure 2.8 Stack

2.4.2 Program Counter (PC)

This 24-bit counter indicates the address of the next instruction the CPU will execute. The length of all CPU instructions is 2 bytes (one word), so the least significant PC bit is ignored. (When an instruction is fetched for read, the least significant PC bit is regarded as 0.)

2.4.3 Extended Control Register (EXR)

EXR does not affect operation in this LSI.

Bit	Bit Name	Initial Value	R/W	Description
7	T	0	R/W	Trace Bit Does not affect operation in this LSI.
6 to 3	—	All 1	R	Reserved These bits are always read as 1.
2 to 0	I2 I1 I0	All 1	R/W	Interrupt Mask Bits 2 to 0 Do not affect operation in this LSI.

2.4.4 Condition-Code Register (CCR)

This 8-bit register contains internal CPU status information, including an interrupt mask bit (I) and half-carry (H), negative (N), zero (Z), overflow (V), and carry (C) flags. Operations can be performed on the CCR bits by the LDC, STC, ANDC, ORC, and XORC instructions. The N, Z, V, and C flags are used as branching conditions for conditional branch (Bcc) instructions.

Bit	Bit Name	Initial Value	R/W	Description
7	I	1	R/W	Interrupt Mask Bit Masks interrupts other than NMI when set to 1. NMI is accepted regardless of the I bit setting. The I bit is set to 1 at the start of an exception-handling sequence. For details, refer to section 5, Interrupt Controller.
6	UI	Undefined	R/W	User Bit or Interrupt Mask Bit Can be written to and read from by software using the LDC, STC, ANDC, ORC, and XORC instructions.
5	H	Undefined	R/W	Half-Carry Flag When the ADD.B, ADDX.B, SUB.B, SUBX.B, CMP.B or NEG.B instruction is executed, this flag is set to 1 if there is a carry or borrow at bit 3, and cleared to 0 otherwise. When the ADD.W, SUB.W, CMP.W, or NEG.W instruction is executed, the H flag is set to 1 if there is a carry or borrow at bit 11, and cleared to 0 otherwise. When the ADD.L, SUB.L, CMP.L, or NEG.L instruction is executed, the H flag is set to 1 if there is a carry or borrow at bit 27, and cleared to 0 otherwise.
4	U	Undefined	R/W	User Bit Can be written to and read from by software using the LDC, STC, ANDC, ORC, and XORC instructions.
3	N	Undefined	R/W	Negative Flag Stores the value of the most significant bit of data as a sign bit.
2	Z	Undefined	R/W	Zero Flag Set to 1 to indicate zero data, and cleared to 0 to indicate non-zero data.
1	V	Undefined	R/W	Overflow Flag Set to 1 when an arithmetic overflow occurs, and cleared to 0 otherwise.

Bit	Bit Name	Initial Value	R/W	Description
0	C	Undefined	R/W	<p>Carry Flag</p> <p>Set to 1 when a carry occurs, and cleared to 0 otherwise. Used by</p> <p>Add instructions, to indicate a carry</p> <p>Subtract instructions, to indicate a borrow</p> <p>Shift and rotate instructions, to indicate a carry</p> <p>The carry flag is also used as a bit accumulator by bit manipulation instructions.</p>

2.4.5 Initial Register Values

The program counter (PC) among CPU internal registers is initialized when reset exception handling loads a start address from a vector table. The trace (T) bit in EXR is cleared to 0, and the interrupt mask (I) bits in CCR and EXR are set to 1. The other CCR bits and the general registers are not initialized. Note that the stack pointer (ER7) is undefined. The stack pointer should therefore be initialized by an MOV.L instruction executed immediately after a reset.

2.5 Data Formats

The H8S/2000 CPU can process 1-bit, 4-bit BCD, 8-bit (byte), 16-bit (word), and 32-bit (longword) data. Bit-manipulation instructions operate on 1-bit data by accessing bit n ($n = 0, 1, 2, \dots, 7$) of byte operand data. The DAA and DAS decimal-adjust instructions treat byte data as two digits of 4-bit BCD data.

2.5.1 General Register Data Formats

Figure 2.9 shows the data formats of general registers.

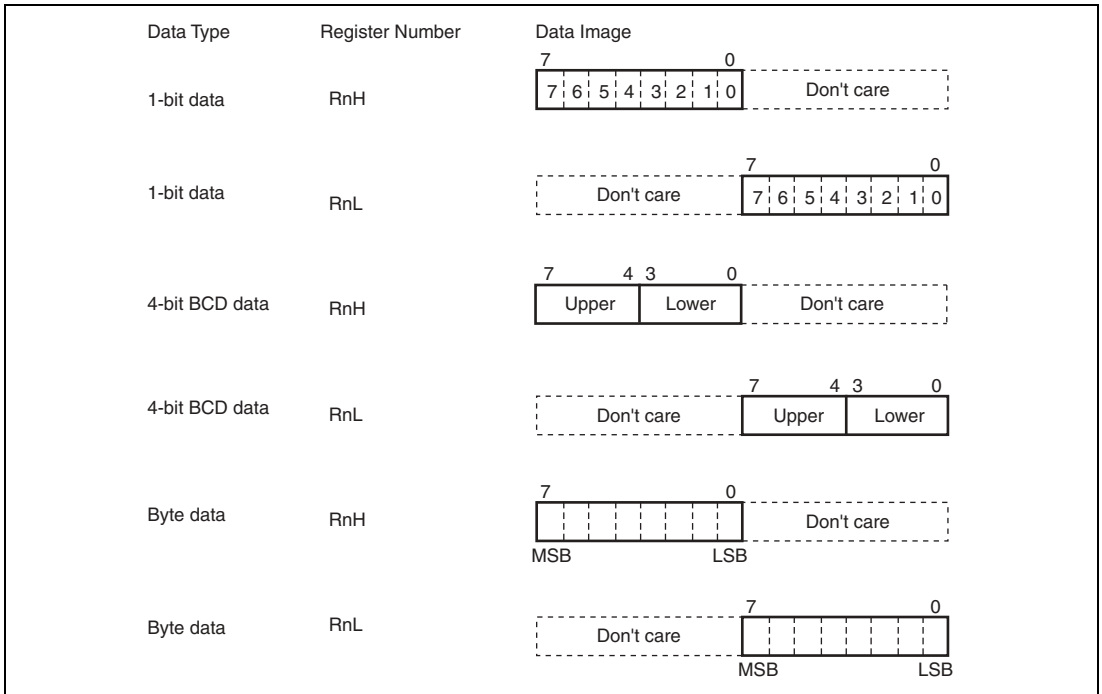
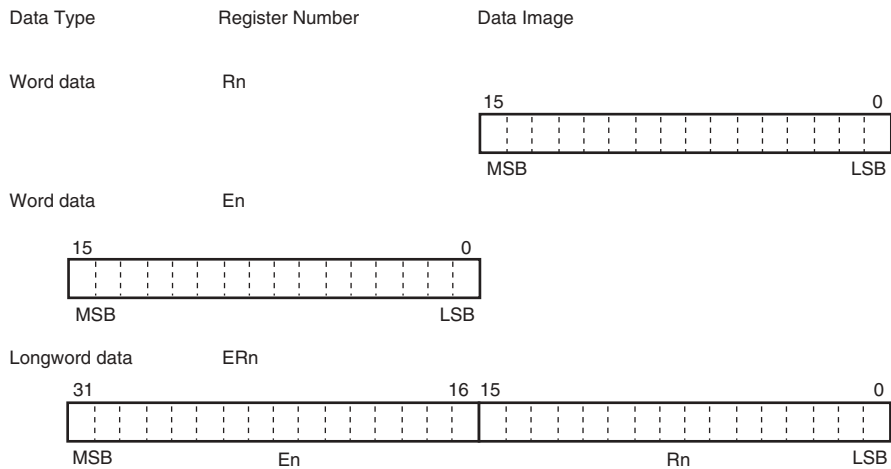

Figure 2.9 General Register Data Formats (1)



[Legend]

- ERn: General register ER
- En: General register E
- Rn: General register R
- RnH: General register RH
- RnL: General register RL
- MSB: Most significant bit
- LSB: Least significant bit

Figure 2.9 General Register Data Formats (2)

2.5.2 Memory Data Formats

Figure 2.10 shows the data formats in memory. The H8S/2000 CPU can access word data and longword data in memory, but word or longword data must begin at an even address. If an attempt is made to access word or longword data at an odd address, no address error occurs but the least significant bit of the address is regarded as 0, so the access starts at the preceding address. This also applies to instruction fetches.

When SP (ER7) is used as an address register to access the stack, the operand size should be word size or longword size.

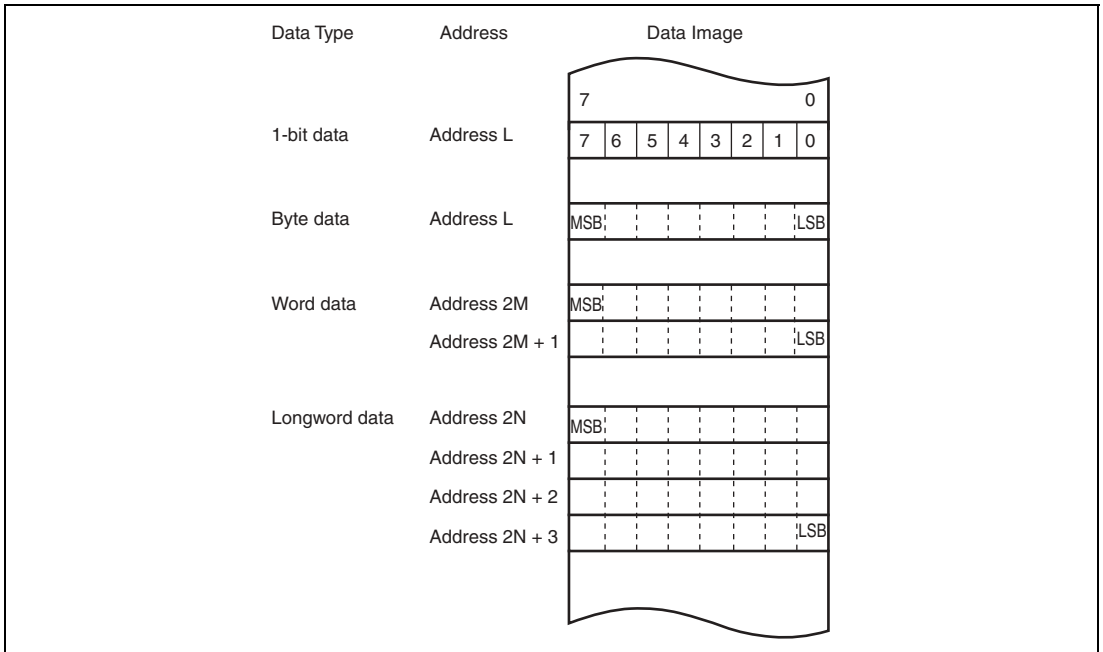

Figure 2.10 Memory Data Formats

2.6 Instruction Set

The H8S/2000 CPU has 65 types of instructions. The instructions are classified by function as shown in table 2.1.

Table 2.1 Instruction Classification

Function	Instructions	Size	Types
Data transfer	MOV	B/W/L	5
	POP* ¹ , PUSH* ¹	W/L	
	LDM* ⁵ , STM* ⁵	L	
	MOVFPE* ³ , MOVTPPE* ³	B	
Arithmetic operations	ADD, SUB, CMP, NEG	B/W/L	19
	ADDX, SUBX, DAA, DAS	B	
	INC, DEC	B/W/L	
	ADDS, SUBS	L	
	MULXU, DIVXU, MULXS, DIVXS	B/W	
	EXTU, EXT5	W/L	
	TAS* ⁴	B	
Logic operations	AND, OR, XOR, NOT	B/W/L	4
Shift	SHAL, SHAR, SHLL, SHLR, ROTL, ROTR, ROTXL, ROTXR	B/W/L	8
Bit manipulation	BSET, BCLR, BNOT, BTST, BLD, BILD, BST, BIST, BAND, BIAND, BOR, BIOR, BXOR, BIXOR	B	14
Branch	B _{cc} * ² , JMP, BSR, JSR, RTS	—	5
System control	TRAPA, RTE, SLEEP, LDC, STC, ANDC, ORC, XORC, NOP	—	9
Block data transfer	EEPMOV	—	1
			Total: 65

Notes: B: Byte size; W: Word size; L: Longword size.

1. POP.W Rn and PUSH.W Rn are identical to MOV.W @SP+, Rn and MOV.W Rn, @-SP. POP.L ERn and PUSH.L ERn are identical to MOV.L @SP+, ERn and MOV.L ERn, @-SP.
2. B_{cc} is the general name for conditional branch instructions.
3. Cannot be used in this LSI.
4. When using the TAS instruction, use registers ER0, ER1, ER4, and ER5.
5. ER7 is not used as the register that can be saved (STM)/restored (LDM) when using STM/LDM instruction, because ER7 is the stack pointer.

2.6.1 Table of Instructions Classified by Function

Tables 2.3 to 2.10 summarize the instructions in each functional category. The notation used in tables 2.3 to 2.10 is defined below.

Table 2.2 Operation Notation

Symbol	Description
Rd	General register (destination)*
Rs	General register (source)*
Rn	General register*
ERn	General register (32-bit register)
(EAd)	Destination operand
(EAs)	Source operand
EXR	Extended control register
CCR	Condition-code register
N	N (negative) flag in CCR
Z	Z (zero) flag in CCR
V	V (overflow) flag in CCR
C	C (carry) flag in CCR
PC	Program counter
SP	Stack pointer
#IMM	Immediate data
disp	Displacement
+	Addition
-	Subtraction
×	Multiplication
÷	Division
^	Logical AND
∨	Logical OR
⊕	Logical exclusive OR
→	Move
~	NOT (logical complement)
:8/:16/:24/:32	8-, 16-, 24-, or 32-bit length

Note: * General registers include 8-bit registers (R0H to R7H, R0L to R7L), 16-bit registers (R0 to R7, E0 to E7), and 32-bit registers (ER0 to ER7).

Table 2.3 Data Transfer Instructions

Instruction	Size*¹	Function
MOV	B/W/L	(EAs) → Rd, Rs → (EAd) Moves data between two general registers or between a general register and memory, or moves immediate data to a general register.
MOVFPE	B	Cannot be used in this LSI.
MOVTPE	B	Cannot be used in this LSI.
POP	W/L	@SP+ → Rn Pops a general register from the stack. POP.W Rn is identical to MOV.W @SP+, Rn. POP.L ERn is identical to MOV.L @SP+, ERn
PUSH	W/L	Rn → @-SP Pushes a general register onto the stack. PUSH.W Rn is identical to MOV.W Rn, @-SP. PUSH.L ERn is identical to MOV.L ERn, @-SP.
LDM* ²	L	@SP+ → Rn (register list) Pops two or more general registers from the stack.
STM* ²	L	Rn (register list) → @-SP Pushes two or more general registers onto the stack.

Notes: 1. Size refers to the operand size.

B: Byte

W: Word

L: Longword

2. ER7 is not used as the register that can be saved (STM)/restored (LDM) when using STM/LDM instruction, because ER7 is the stack pointer.

Table 2.4 Arithmetic Operations Instructions (1)

Instruction	Size*	Function
ADD SUB	B/W/L	$Rd \pm Rs \rightarrow Rd$, $Rd \pm \#IMM \rightarrow Rd$ Performs addition or subtraction on data in two general registers, or on immediate data and data in a general register. (Subtraction on immediate data and data in a general register cannot be performed in bytes. Use the SUBX or ADD instruction.)
ADDX SUBX	B	$Rd \pm Rs \pm C \rightarrow Rd$, $Rd \pm \#IMM \pm C \rightarrow Rd$ Performs addition or subtraction with carry on data in two general registers, or on immediate data and data in a general register.
INC DEC	B/W/L	$Rd \pm 1 \rightarrow Rd$, $Rd \pm 2 \rightarrow Rd$ Adds or subtracts the value 1 or 2 to or from data in a general register. (Only the value 1 can be added to or subtracted from byte operands.)
ADDS SUBS	L	$Rd \pm 1 \rightarrow Rd$, $Rd \pm 2 \rightarrow Rd$, $Rd \pm 4 \rightarrow Rd$ Adds or subtracts the value 1, 2, or 4 to or from data in a 32-bit register.
DAA DAS	B	Rd (decimal adjust) $\rightarrow Rd$ Decimal-adjusts an addition or subtraction result in a general register by referring to CCR to produce 4-bit BCD data.
MULXU	B/W	$Rd \times Rs \rightarrow Rd$ Performs unsigned multiplication on data in two general registers: either 8 bits \times 8 bits \rightarrow 16 bits or 16 bits \times 16 bits \rightarrow 32 bits.
MULXS	B/W	$Rd \times Rs \rightarrow Rd$ Performs signed multiplication on data in two general registers: either 8 bits \times 8 bits \rightarrow 16 bits or 16 bits \times 16 bits \rightarrow 32 bits.
DIVXU	B/W	$Rd \div Rs \rightarrow Rd$ Performs unsigned division on data in two general registers: either 16 bits \div 8 bits \rightarrow 8-bit quotient and 8-bit remainder or 32 bits \div 16 bits \rightarrow 16-bit quotient and 16-bit remainder.

Note: * Size refers to the operand size.

B: Byte

W: Word

L: Longword

Table 2.4 Arithmetic Operations Instructions (2)

Instruction	Size*¹	Function
DIVXS	B/W	Rd \div Rs \rightarrow Rd Performs signed division on data in two general registers: either 16 bits \div 8 bits \rightarrow 8-bit quotient and 8-bit remainder or 32 bits \div 16 bits \rightarrow 16-bit quotient and 16-bit remainder.
CMP	B/W/L	Rd $-$ Rs, Rd $-$ #IMM Compares data in a general register with data in another general register or with immediate data, and sets the CCR bits according to the result.
NEG	B/W/L	0 $-$ Rd \rightarrow Rd Takes the two's complement (arithmetic complement) of data in a general register.
EXTU	W/L	Rd (zero extension) \rightarrow Rd Extends the lower 8 bits of a 16-bit register to word size, or the lower 16 bits of a 32-bit register to longword size, by padding with zeros on the left.
EXTS	W/L	Rd (sign extension) \rightarrow Rd Extends the lower 8 bits of a 16-bit register to word size, or the lower 16 bits of a 32-bit register to longword size, by extending the sign bit.
TAS* ²	B	@ERd $-$ 0, 1 \rightarrow (<bit 7> of @ERd) Tests memory contents, and sets the most significant bit (bit 7) to 1.

Notes: 1. Size refers to the operand size.

B: Byte

W: Word

L: Longword

2. When using the TAS instruction, use registers ER0, ER1, ER4 and ER5.

Table 2.5 Logic Operations Instructions

Instruction	Size*	Function
AND	B/W/L	$Rd \wedge Rs \rightarrow Rd, Rd \wedge \#IMM \rightarrow Rd$ Performs a logical AND operation on a general register and another general register or immediate data.
OR	B/W/L	$Rd \vee Rs \rightarrow Rd, Rd \vee \#IMM \rightarrow Rd$ Performs a logical OR operation on a general register and another general register or immediate data.
XOR	B/W/L	$Rd \oplus Rs \rightarrow Rd, Rd \oplus \#IMM \rightarrow Rd$ Performs a logical exclusive OR operation on a general register and another general register or immediate data.
NOT	B/W/L	$\sim Rd \rightarrow Rd$ Takes the one's complement (logical complement) of data in a general register.

Note: * Size refers to the operand size.

B: Byte

W: Word

L: Longword

Table 2.6 Shift Instructions

Instruction	Size*	Function
SHAL SHAR	B/W/L	$Rd \text{ (shift)} \rightarrow Rd$ Performs an arithmetic shift on data in a general register. 1-bit or 2 bit shift is possible.
SHLL SHLR	B/W/L	$Rd \text{ (shift)} \rightarrow Rd$ Performs a logical shift on data in a general register. 1-bit or 2 bit shift is possible.
ROTL ROTR	B/W/L	$Rd \text{ (rotate)} \rightarrow Rd$ Rotates data in a general register. 1-bit or 2 bit rotation is possible.
ROTXL ROTXR	B/W/L	$Rd \text{ (rotate)} \rightarrow Rd$ Rotates data including the carry flag in a general register. 1-bit or 2 bit rotation is possible.

Note: * Size refers to the operand size.

B: Byte

W: Word

L: Longword

Table 2.7 Bit Manipulation Instructions (1)

Instruction	Size*	Function
BSET	B	$1 \rightarrow \langle \text{bit-No.} \rangle \text{ of } \langle \text{EAd} \rangle$ Sets a specified bit in a general register or memory operand to 1. The bit number is specified by 3-bit immediate data or the lower three bits of a general register.
BCLR	B	$0 \rightarrow \langle \text{bit-No.} \rangle \text{ of } \langle \text{EAd} \rangle$ Clears a specified bit in a general register or memory operand to 0. The bit number is specified by 3-bit immediate data or the lower three bits of a general register.
BNOT	B	$\sim \langle \text{bit-No.} \rangle \text{ of } \langle \text{EAd} \rangle \rightarrow \langle \text{bit-No.} \rangle \text{ of } \langle \text{EAd} \rangle$ Inverts a specified bit in a general register or memory operand. The bit number is specified by 3-bit immediate data or the lower three bits of a general register.
BTST	B	$\sim \langle \text{bit-No.} \rangle \text{ of } \langle \text{EAd} \rangle \rightarrow Z$ Tests a specified bit in a general register or memory operand and sets or clears the Z flag accordingly. The bit number is specified by 3-bit immediate data or the lower three bits of a general register.
BAND	B	$C \wedge \langle \text{bit-No.} \rangle \text{ of } \langle \text{EAd} \rangle \rightarrow C$ Logically ANDs the carry flag with a specified bit in a general register or memory operand and stores the result in the carry flag.
BIAND	B	$C \wedge (\sim \langle \text{bit-No.} \rangle \text{ of } \langle \text{EAd} \rangle) \rightarrow C$ Logically ANDs the carry flag with the inverse of a specified bit in a general register or memory operand and stores the result in the carry flag. The bit number is specified by 3-bit immediate data.
BOR	B	$C \vee \langle \text{bit-No.} \rangle \text{ of } \langle \text{EAd} \rangle \rightarrow C$ Logically ORs the carry flag with a specified bit in a general register or memory operand and stores the result in the carry flag.
BIOR	B	$C \vee (\sim \langle \text{bit-No.} \rangle \text{ of } \langle \text{EAd} \rangle) \rightarrow C$ Logically ORs the carry flag with the inverse of a specified bit in a general register or memory operand and stores the result in the carry flag. The bit number is specified by 3-bit immediate data.

Note: * Size refers to the operand size.

B: Byte

Table 2.7 Bit Manipulation Instructions (2)

Instruction	Size*	Function
BXOR	B	$C \oplus \langle \text{bit-No.} \rangle \text{ of } \langle \text{EAd} \rangle \rightarrow C$ Logically exclusive-ORs the carry flag with a specified bit in a general register or memory operand and stores the result in the carry flag.
BIXOR	B	$C \oplus \sim \langle \text{bit-No.} \rangle \text{ of } \langle \text{EAd} \rangle \rightarrow C$ Logically exclusive-ORs the carry flag with the inverse of a specified bit in a general register or memory operand and stores the result in the carry flag. The bit number is specified by 3-bit immediate data.
BLD	B	$\langle \text{bit-No.} \rangle \text{ of } \langle \text{EAd} \rangle \rightarrow C$ Transfers a specified bit in a general register or memory operand to the carry flag.
BILD	B	$\sim \langle \text{bit-No.} \rangle \text{ of } \langle \text{EAd} \rangle \rightarrow C$ Transfers the inverse of a specified bit in a general register or memory operand to the carry flag. The bit number is specified by 3-bit immediate data.
BST	B	$C \rightarrow \langle \text{bit-No.} \rangle \text{ of } \langle \text{EAd} \rangle$ Transfers the carry flag value to a specified bit in a general register or memory operand.
BIST	B	$\sim C \rightarrow \langle \text{bit-No.} \rangle \text{ of } \langle \text{EAd} \rangle$ Transfers the inverse of the carry flag value to a specified bit in a general register or memory operand. The bit number is specified by 3-bit immediate data.

Note: * Size refers to the operand size.

B: Byte

Table 2.8 Branch Instructions

Instruction	Size	Function																																																			
Bcc	—	Branches to a specified address if a specified condition is true. The branching conditions are listed below.																																																			
		<table border="1"> <thead> <tr> <th>Mnemonic</th> <th>Description</th> <th>Condition</th> </tr> </thead> <tbody> <tr> <td>BRA (BT)</td> <td>Always (true)</td> <td>Always</td> </tr> <tr> <td>BRN (BF)</td> <td>Never (false)</td> <td>Never</td> </tr> <tr> <td>BHI</td> <td>High</td> <td>$C \vee Z = 0$</td> </tr> <tr> <td>BLS</td> <td>Low or same</td> <td>$C \vee Z = 1$</td> </tr> <tr> <td>BCC (BHS)</td> <td>Carry clear (high or same)</td> <td>$C = 0$</td> </tr> <tr> <td>BCS (BLO)</td> <td>Carry set (low)</td> <td>$C = 1$</td> </tr> <tr> <td>BNE</td> <td>Not equal</td> <td>$Z = 0$</td> </tr> <tr> <td>BEQ</td> <td>Equal</td> <td>$Z = 1$</td> </tr> <tr> <td>BVC</td> <td>Overflow clear</td> <td>$V = 0$</td> </tr> <tr> <td>BVS</td> <td>Overflow set</td> <td>$V = 1$</td> </tr> <tr> <td>BPL</td> <td>Plus</td> <td>$N = 0$</td> </tr> <tr> <td>BMI</td> <td>Minus</td> <td>$N = 1$</td> </tr> <tr> <td>BGE</td> <td>Greater or equal</td> <td>$N \oplus V = 0$</td> </tr> <tr> <td>BLT</td> <td>Less than</td> <td>$N \oplus V = 1$</td> </tr> <tr> <td>BGT</td> <td>Greater than</td> <td>$Z \vee (N \oplus V) = 0$</td> </tr> <tr> <td>BLE</td> <td>Less or equal</td> <td>$Z \vee (N \oplus V) = 1$</td> </tr> </tbody> </table>	Mnemonic	Description	Condition	BRA (BT)	Always (true)	Always	BRN (BF)	Never (false)	Never	BHI	High	$C \vee Z = 0$	BLS	Low or same	$C \vee Z = 1$	BCC (BHS)	Carry clear (high or same)	$C = 0$	BCS (BLO)	Carry set (low)	$C = 1$	BNE	Not equal	$Z = 0$	BEQ	Equal	$Z = 1$	BVC	Overflow clear	$V = 0$	BVS	Overflow set	$V = 1$	BPL	Plus	$N = 0$	BMI	Minus	$N = 1$	BGE	Greater or equal	$N \oplus V = 0$	BLT	Less than	$N \oplus V = 1$	BGT	Greater than	$Z \vee (N \oplus V) = 0$	BLE	Less or equal	$Z \vee (N \oplus V) = 1$
Mnemonic	Description	Condition																																																			
BRA (BT)	Always (true)	Always																																																			
BRN (BF)	Never (false)	Never																																																			
BHI	High	$C \vee Z = 0$																																																			
BLS	Low or same	$C \vee Z = 1$																																																			
BCC (BHS)	Carry clear (high or same)	$C = 0$																																																			
BCS (BLO)	Carry set (low)	$C = 1$																																																			
BNE	Not equal	$Z = 0$																																																			
BEQ	Equal	$Z = 1$																																																			
BVC	Overflow clear	$V = 0$																																																			
BVS	Overflow set	$V = 1$																																																			
BPL	Plus	$N = 0$																																																			
BMI	Minus	$N = 1$																																																			
BGE	Greater or equal	$N \oplus V = 0$																																																			
BLT	Less than	$N \oplus V = 1$																																																			
BGT	Greater than	$Z \vee (N \oplus V) = 0$																																																			
BLE	Less or equal	$Z \vee (N \oplus V) = 1$																																																			
JMP	—	Branches unconditionally to a specified address.																																																			
BSR	—	Branches to a subroutine at a specified address																																																			
JSR	—	Branches to a subroutine at a specified address																																																			
RTS	—	Returns from a subroutine																																																			

Table 2.9 System Control Instructions

Instruction	Size*	Function
TRAPA	—	Starts trap-instruction exception handling.
RTE	—	Returns from an exception-handling routine.
SLEEP	—	Causes a transition to a power-down state.
LDC	B/W	(EAs) → CCR, (EAs) → EXR Moves the memory operand contents or immediate data to CCR or EXR. Although CCR and EXR are 8-bit registers, word-size transfers are performed between them and memory. The upper 8 bits are valid.
STC	B/W	CCR → (EAd), EXR → (EAd) Transfers CCR or EXR contents to a general register or memory operand. Although CCR and EXR are 8-bit registers, word-size transfers are performed between them and memory. The upper 8 bits are valid.
ANDC	B	CCR ∧ #IMM → CCR, EXR ∧ #IMM → EXR Logically ANDs the CCR or EXR contents with immediate data.
ORC	B	CCR ∨ #IMM → CCR, EXR ∨ #IMM → EXR Logically ORs the CCR or EXR contents with immediate data.
XORC	B	CCR ⊕ #IMM → CCR, EXR ⊕ #IMM → EXR Logically exclusive-ORs the CCR or EXR contents with immediate data.
NOP	—	PC + 2 → PC Only increments the program counter.

Note: * Size refers to the operand size.

B: Byte

W: Word

Table 2.10 Block Data Transfer Instructions

Instruction	Size	Function
EEPMOV.B	—	if R4L ≠ 0 then Repeat @ER5 + → @ER6+ R4L-1 → R4L Until R4L = 0 else next;
EEPMOV.W	—	if R4 ≠ 0 then Repeat @ER5 + → @ER6+ R4-1 → R4 Until R4 = 0 else next; Transfers a data block. Starting from the address set in ER5, transfers data for the number of bytes set in R4L or R4 to the address location set in ER6. Execution of the next instruction begins as soon as the transfer is completed.

2.6.2 Basic Instruction Formats

The H8S/2000 CPU instructions consist of 2-byte (1-word) units. An instruction consists of an operation field (op), a register field (r), an effective address extension (EA), and a condition field (cc).

Figure 2.11 shows examples of instruction formats.

- **Operation field**
Indicates the function of the instruction, the addressing mode, and the operation to be carried out on the operand. The operation field always includes the first four bits of the instruction. Some instructions have two operation fields.
- **Register field**
Specifies a general register. Address registers are specified by 3 bits, and data registers by 3 bits or 4 bits. Some instructions have two register fields, and some have no register field.
- **Effective address extension**
8, 16, or 32 bits specifying immediate data, an absolute address, or a displacement.
- **Condition field**
Specifies the branching condition of Bcc instructions.

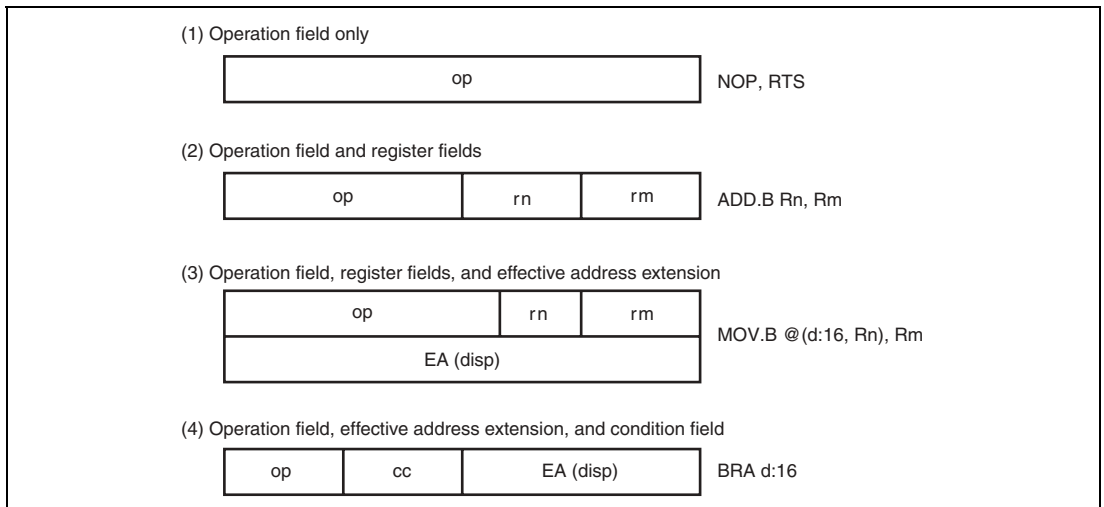

Figure 2.11 Instruction Formats (Examples)

2.7 Addressing Modes and Effective Address Calculation

The H8S/2000 CPU supports the eight addressing modes listed in table 2.11. Each instruction uses a subset of these addressing modes.

Arithmetic and logic operations instructions can use the register direct and immediate addressing modes. Data transfer instructions can use all addressing modes except program-counter relative and memory indirect. Bit manipulation instructions can use register direct, register indirect, or absolute addressing mode to specify an operand, and register direct (BSET, BCLR, BNOT, and BTST instructions) or immediate (3-bit) addressing mode to specify a bit number in the operand.

Table 2.11 Addressing Modes

No.	Addressing Mode	Symbol
1	Register direct	Rn
2	Register indirect	@ERn
3	Register indirect with displacement	@(d:16,ERn)/@(d:32,ERn)
4	Register indirect with post-increment	@ERn+
	Register indirect with pre-decrement	@-ERn
5	Absolute address	@aa:8/@aa:16/@aa:24/@aa:32
6	Immediate	#xx:8/#xx:16/#xx:32
7	Program-counter relative	@(d:8,PC)/@(d:16,PC)
8	Memory indirect	@@aa:8

2.7.1 Register Direct—Rn

The register field of the instruction code specifies an 8-, 16-, or 32-bit general register which contains the operand. R0H to R7H and R0L to R7L can be specified as 8-bit registers. R0 to R7 and E0 to E7 can be specified as 16-bit registers. ER0 to ER7 can be specified as 32-bit registers.

2.7.2 Register Indirect—@ERn

The register field of the instruction code specifies an address register (ERn) which contains the address of a memory operand. If the address is a program instruction address, the lower 24 bits are valid and the upper 8 bits are all assumed to be 0 (H'00).

2.7.3 Register Indirect with Displacement—@(d:16, ERn) or @(d:32, ERn)

A 16-bit or 32-bit displacement contained in the instruction code is added to an address register (ERn) specified by the register field of the instruction, and the sum gives the address of a memory operand. A 16-bit displacement is sign-extended when added.

2.7.4 Register Indirect with Post-Increment or Pre-Decrement—@ERn+ or @-ERn

Register Indirect with Post-Increment—@ERn+: The register field of the instruction code specifies an address register (ERn) which contains the address of a memory operand. After the operand is accessed, 1, 2, or 4 is added to the address register contents and the sum is stored in the address register. The value added is 1 for byte access, 2 for word access, and 4 for longword access. For word or longword transfer instructions, the register value should be even.

Register Indirect with Pre-Decrement—@-ERn: The value 1, 2, or 4 is subtracted from an address register (ERn) specified by the register field in the instruction code, and the result becomes the address of a memory operand. The result is also stored in the address register. The value subtracted is 1 for byte access, 2 for word access, and 4 for longword access. For word or longword transfer instructions, the register value should be even.

2.7.5 Absolute Address—@aa:8, @aa:16, @aa:24, or @aa:32

The instruction code contains the absolute address of a memory operand. The absolute address may be 8 bits long (@aa:8), 16 bits long (@aa:16), 24 bits long (@aa:24), or 32 bits long (@aa:32). Table 2.12 indicates the accessible absolute address ranges.

To access data, the absolute address should be 8 bits (@aa:8), 16 bits (@aa:16), or 32 bits (@aa:32) long. For an 8-bit absolute address, the upper 16 bits are all assumed to be 1 (H'FFFF). For a 16-bit absolute address, the upper 16 bits are a sign extension. For a 32-bit absolute address, the entire address space is accessed.

A 24-bit absolute address (@aa:24) indicates the address of a program instruction. The upper 8 bits are all assumed to be 0 (H'00).

Table 2.12 Absolute Address Access Ranges

Absolute Address		Normal Mode	Advanced Mode
Data address	8 bits (@aa:8)	H'FF00 to H'FFFF	H'FFFF00 to H'FFFFFF
	16 bits (@aa:16)	H'0000 to H'FFFF	H'000000 to H'007FFF, H'FF8000 to H'FFFFFF
	32 bits (@aa:32)		H'000000 to H'FFFFFF
Program instruction address	24 bits (@aa:24)		

2.7.6 Immediate—#xx:8, #xx:16, or #xx:32

The 8-bit (#xx:8), 16-bit (#xx:16), or 32-bit (#xx:32) immediate data contained in an instruction code can be used directly as an operand.

The ADDS, SUBS, INC, and DEC instructions implicitly contain immediate data in their instruction codes. Some bit manipulation instructions contain 3-bit immediate data in the instruction code, specifying a bit number. The TRAPA instruction contains 2-bit immediate data in its instruction code, specifying a vector address.

2.7.7 Program-Counter Relative—@(d:8, PC) or @(d:16, PC)

This mode can be used by the Bcc and BSR instructions. An 8-bit or 16-bit displacement contained in the instruction code is sign-extended to 24 bits and added to the 24-bit address indicated by the PC value to generate a 24-bit branch address. Only the lower 24 bits of this branch address are valid; the upper 8 bits are all assumed to be 0 (H'00). The PC value to which the displacement is added is the address of the first byte of the next instruction, so the possible branching range is -126 to +128 bytes (-63 to +64 words) or -32766 to +32768 bytes (-16383 to +16384 words) from the branch instruction. The resulting value should be an even number.

2.7.8 Memory Indirect—@@aa:8

This mode can be used by the JMP and JSR instructions. The instruction code contains an 8-bit absolute address specifying a memory operand which contains a branch address. The upper bits of the 8-bit absolute address are all assumed to be 0, so the address range is 0 to 255 (H'0000 to H'00FF in normal mode, H'000000 to H'0000FF in advanced mode).

In normal mode, the memory operand is a word operand and the branch address is 16 bits long. In advanced mode, the memory operand is a longword operand, the first byte of which is assumed to be 0 (H'00). Note that the top area of the address range in which the branch address is stored is also used for the exception vector area. For further details, refer to section 4, Exception Handling.

If an odd address is specified in word or longword memory access, or as a branch address, the least significant bit is regarded as 0, causing data to be accessed or the instruction code to be fetched at the address preceding the specified address. (For further information, see section 2.5.2, Memory Data Formats.)

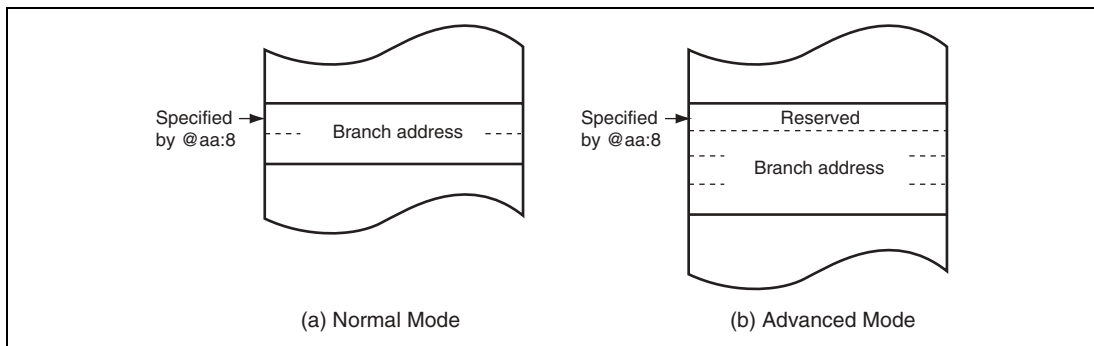

Figure 2.12 Branch Address Specification in Memory Indirect Addressing Mode

2.7.9 Effective Address Calculation

Table 2.13 indicates how effective addresses are calculated in each addressing mode. In normal mode, the upper 8 bits of the effective address are ignored in order to generate a 16-bit address.

Table 2.13 Effective Address Calculation (1)







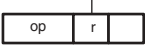

No	Addressing Mode and Instruction Format	Effective Address Calculation	Effective Address (EA)								
1	Register direct (Rn) 		Operand is general register contents.								
2	Register indirect (@ERn) 										
3	Register indirect with displacement @d:(16,ERn) or @:(d:32,ERn) 										
4	Register indirect with post-increment or pre-decrement • Register indirect with post-increment @ERn+  • Register indirect with pre-decrement @-ERn 	  <table border="1" data-bbox="463 949 650 1029"> <thead> <tr> <th>Operand Size</th> <th>Offset</th> </tr> </thead> <tbody> <tr> <td>Byte</td> <td>1</td> </tr> <tr> <td>Word</td> <td>2</td> </tr> <tr> <td>Longword</td> <td>4</td> </tr> </tbody> </table>	Operand Size	Offset	Byte	1	Word	2	Longword	4	 
Operand Size	Offset										
Byte	1										
Word	2										
Longword	4										

Table 2.13 Effective Address Calculation (2)

No	Addressing Mode and Instruction Format	Effective Address Calculation	Effective Address (EA)
5	Absolute address @aa:8 		
	@aa:16 		
	@aa:24 		
	@aa:32 		
6	Immediate #xx:B/#xx:16/#xx:32 		Operand is immediate data.
7	Program-counter relative @(d:8,PC)@(d:16,PC) 		
8	Memory indirect @aa:8 		

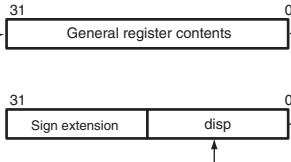
2.8 Processing States

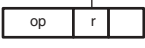
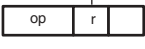
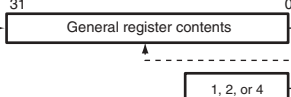
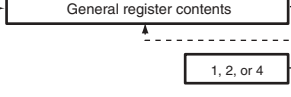
The H8S/2000 CPU has four main processing states: the reset state, exception handling state, program execution state, and program stop state. Figure 2.13 indicates the state transitions.

- Reset state

In this state the CPU and on-chip peripheral modules are all initialized and stopped. When the $\overline{\text{RES}}$ input goes low, all current processing stops and the CPU enters the reset state. All interrupts are masked in the reset state. Reset exception handling starts when the $\overline{\text{RES}}$ signal changes from low to high. For details, refer to section 4, Exception Handling.

The reset state can also be entered by a watchdog timer overflow.

- Exception-handling state

The exception-handling state is a transient state that occurs when the CPU alters the normal processing flow due to an exception source, such as, a reset, trace, interrupt, or trap instruction. The CPU fetches a start address (vector) from the exception vector table and branches to that address. For further details, refer to section 4, Exception Handling.

- Program execution state

In this state the CPU executes program instructions in sequence.

- Program stop state

This is a power-down state in which the CPU stops operating. The program stop state occurs when a SLEEP instruction is executed or the CPU enters hardware standby mode. For details, refer to section 20, Power-Down Modes.

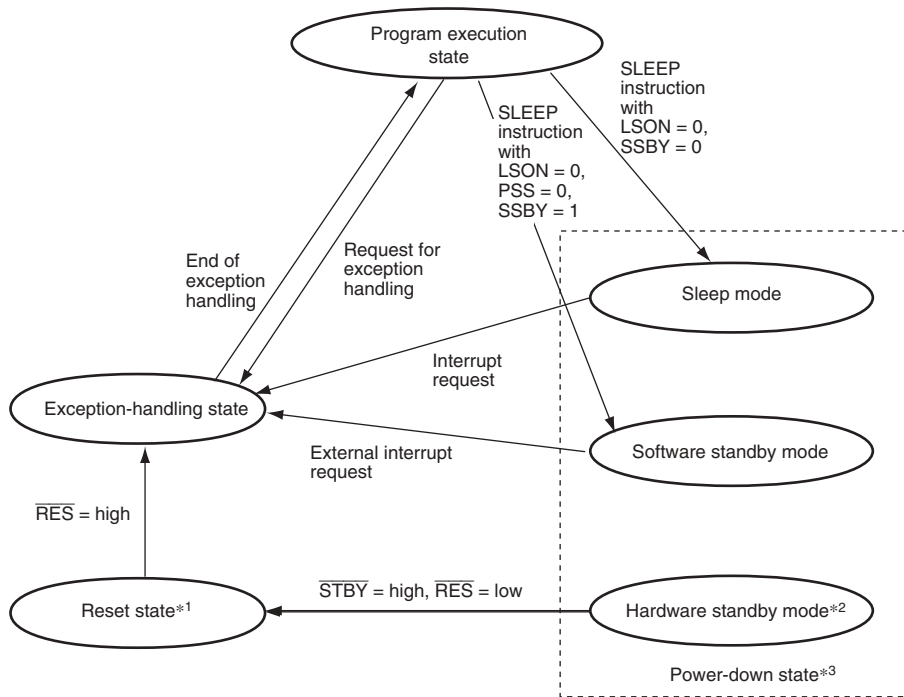

- Notes:
1. From any state except hardware standby mode, a transition to the reset state occurs whenever $\overline{\text{RES}}$ goes low. A transition can also be made to the reset state when the watchdog timer overflows.
 2. From any state, a transition to hardware standby mode occurs when $\overline{\text{STBY}}$ goes low.
 3. The power-down state also includes watch mode, subactive mode, subsleep mode, etc. For details, refer to section 20, Power-Down Modes.

Figure 2.13 State Transitions

2.9 Usage Notes

2.9.1 Note on TAS Instruction Usage

When using the TAS instruction, use registers ER0, ER1, ER4 and ER5.

The TAS instruction is not generated by the Renesas Technology H8S and H8/300 series C/C++ compilers. When the TAS instruction is used as a user-defined intrinsic function, use registers ER0, ER1, ER4 and ER5.

2.9.2 Note on STM/LDM Instruction Usage

ER7 is not used as the register that can be saved (STM)/restored (LDM) when using STM/LDM instruction, because ER7 is the stack pointer. Two, three, or four registers can be saved/restored by one STM/LDM instruction. The following ranges can be specified in the register list.

Two registers: ER0—ER1, ER2—ER3, or ER4—ER5

Three registers: ER0—ER2 or ER4—ER6

Four registers: ER0—ER3

The STM/LDM instruction including ER7 is not generated by the Renesas Technology H8S and H8/300 series C/C++ compilers.

2.9.3 Note on Bit Manipulation Instructions

The BSET, BCLR, BNOT, BST, and BIST instructions read data in byte units, manipulate the data of the target bit, and write data in byte units. Special care is required when using these instructions in cases where a register containing a write-only bit is used or a bit is directly manipulated for a port.

In addition, the BCLR instruction can be used to clear the flag of the internal I/O register. In this case, if the flag to be cleared has been set to 1 by an interrupt processing routine, the flag need not be read before executing the BCLR instruction.

2.9.4 EEPMOV Instruction

1. EEPMOV is a block-transfer instruction and transfers the byte size of data indicated by R4L, which starts from the address indicated by R5, to the address indicated by R6.

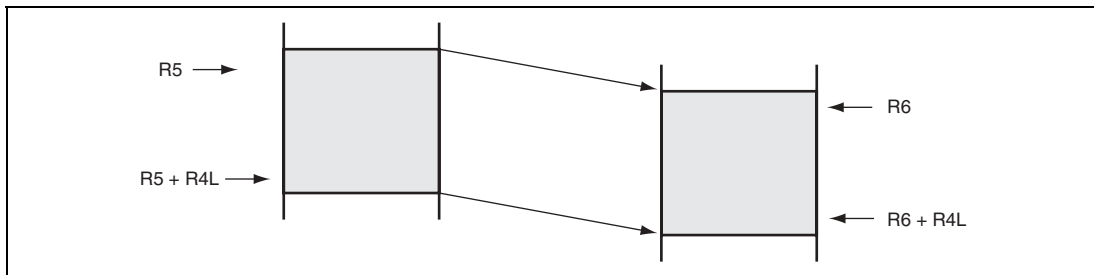

2. Set R4L and R6 so that the end address of the destination address (value of R6 + R4L) does not exceed H'FFFF (the value of R6 must not change from H'FFFF to H'0000 during execution).

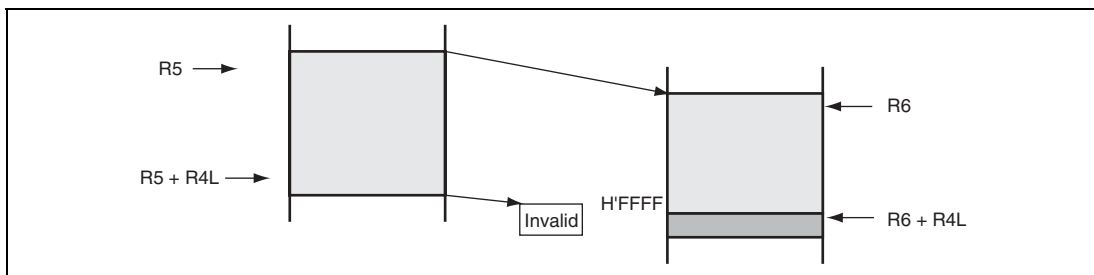

Section 3 MCU Operating Modes

3.1 MCU Operating Mode Selection

This LSI has two operating modes (modes 2 and 3). The operating mode is determined by the setting of the mode pins (MD1 and MD0). Table 3.1 shows the MCU operating mode selection.

Table 3.1 lists the MCU operating modes.

Table 3.1 MCU Operating Mode Selection

MCU Operating Mode	MD1	MD0	CPU Operating Mode	Description	On-Chip ROM
2	1	0	Advanced	Single-chip mode	Enabled
3		1	Normal	Single-chip mode	

Modes 2 and 3 set the operation in single-chip mode.

Modes 0 and 1 cannot be used in this LSI. Thus, mode pins should be set to enable mode 2 or 3 in normal program execution state. Mode pins should not be changed during operation.

3.2 Register Descriptions

The following registers are related to the operating mode.

Mode control register (MDCR)

System control register (SYSCR)

Serial timer control register (STCR)

3.2.1 Mode Control Register (MDCR)

MDCR is used to monitor the current operating mode.

Bit	Bit Name	Initial Value	R/W	Description
7	EXPE	0	R/W	Reserved The initial value should not be changed.
6 to 2	—	All 0	R	Reserved These bits are always read as 0. These bits cannot be modified.
1	MDS1	—*	R	Mode Select 1 and 0
0	MDS0	—*	R	These bits indicate the input levels at mode pins (MD1 and MD0) (the current operating mode). Bits MDS1 and MDS0 correspond to MD1 and MD0, respectively. These bits are read-only bits and they cannot be written to. The mode pin (MD1 and MD0) input levels are latched into these bits when MDCR is read. These latches are canceled by a reset.

Note: * The initial values are determined by the settings of the MD1 and MD0 pins.

3.2.2 System Control Register (SYSCR)

SYSCR selects a system pin function, monitors a reset source, selects the interrupt control mode and the detection edge for NMI, pin location selection, enables or disables register access to the on-chip peripheral modules, and enables or disables on-chip RAM address space.

Bit	Bit Name	Initial Value	R/W	Description
7 and 6	—	All 0	R/W	Reserved The initial value should not be changed.
5	INTM1	0	R	These bits select the control mode of the interrupt controller. For details on the interrupt control modes and interrupt control select modes 1 and 0, see section 5.6, Interrupt Control Modes and Interrupt Operation. 00: Interrupt control mode 0 01: Interrupt control mode 1 10: Setting prohibited 11: Setting prohibited
4	INTM0	0	R/W	
3	XRST	1	R	External Reset This bit indicates the reset source. A reset is caused by an external reset input, or when the watchdog timer overflows. 0: A reset is caused when the watchdog timer overflows. 1: A reset is caused by an external reset.
2	NMIEG	0	R/W	NMI Edge Select Selects the valid edge of the NMI interrupt input. 0: An interrupt is requested at the falling edge of NMI input 1: An interrupt is requested at the rising edge of NMI input

Bit	Bit Name	Initial Value	R/W	Description
1	HIE	0	R/W	<p>Host Interface Enable</p> <p>Controls CPU access to the keyboard matrix interrupt, input pull-up MOS control registers (KMIMR, KMPCR, and KMIMRA), and the 8-bit timer (TMR_X and TMR_Y) registers (TCR_X/TCR_Y, TCSR_X/TCSR_Y, TICRR/TCORA_Y, TICRF/TCORB_Y, TCNT_X/TCNT_Y, TCORC/TISR, TCORA_X, and TCORB_X, TCONRI, and TCONRS).</p> <p>0: In areas H'(FF)FFF0 to H'(FF)FFF7 and H'(FF)FFFC to H'(FF)FFFF, CPU access to 8-bit timer (TMR_X and TMR_Y) is permitted.</p> <p>1: In areas H'(FF)FFF0 to H'(FF)FFF7 and H'(FF)FFFC to H'(FF)FFFF, CPU access to keyboard matrix interrupt and input pull-up MOS control registers is permitted.</p>
0	RAME	1	R/W	<p>RAM Enable</p> <p>Enables or disables on-chip RAM. The RAME bit is initialized when the reset state is released.</p> <p>0: On-chip RAM is disabled</p> <p>1: On-chip RAM is enabled</p>

3.2.3 Serial Timer Control Register (STCR)

STCR enables or disables register access, IIC operating mode, and on-chip flash memory, and selects the input clock of the timer counter.

Bit	Bit Name	Initial Value	R/W	Description
7	IICS	0	R/W	<p>I²C Extra Buffer Select</p> <p>Specifies bits 7 to 4 of port A as output buffers similar to SLC and SDA. These pins are used to implement an I²C interface only by software.</p> <p>0: PA7 to PA4 are normal input/output pins.</p> <p>1: PA7 to PA4 are input/output pins enabling bus driving.</p>
6	IICX1	0	R/W	I ² C Transfer Rate Select 1 and 0
5	IICX0	0	R/W	<p>These bits control the IIC operation. These bits select a transfer rate in master mode together with bits CKS2 to CKS0 in the I²C bus mode register (ICMR). For details on the transfer rate, refer to table 13.3.</p>
4	IICE	0	R/W	<p>I²C Master Enable</p> <p>Enables or disables CPU access for IIC registers (ICCR, ICSR, ICDR/SARX, ICMR/SAR), and SCI registers (SMR, BRR, SCMR).</p> <p>0: SCI_1 registers are accessed in an area from H'(FF)FF88 to H'(FF)FF89 and from H'(FF)FF8E to H'(FF)FF8F.</p> <p>1: IIC_1 registers are accessed in an area from H'(FF)FF88 to H'(FF)FF89 and from H'(FF)FF8E to H'(FF)FF8F.</p> <p>IIC_0 registers are accessed in an area from H'(FF)FFD8 to H'(FF)FFD9 and from H'(FF)FFDE to H'(FF)FFDF.</p>

Bit	Bit Name	Initial Value	R/W	Description
3	FLSHE	0	R/W	Flash Memory Control Register Enable Enables or disables CPU access for flash memory registers (FLMCR1, FLMCR2, EBR1, EBR2), control registers in power-down state (SBYCR, LPWRCCR, MSTPCRH, MSTPCRL), and control registers of on-chip peripheral modules (PCSR, SYSCR2). 0: Registers in power-down state and control registers of on-chip peripheral modules are accessed in an area from H'(FF)FF80 to H'(FF)FF87. 1: Control registers of flash memory are accessed in an area from H'(FF)FF80 to H'(FF)FF87.
2	—	0	R/(W)	Reserved The initial value should not be changed.
1	ICKS1	0	R/W	Internal Clock Source Select 1, 0
0	ICKS0	0	R/W	These bits select a clock to be input to the timer counter (TCNT) and a count condition together with bits CKS2 to CKS0 in the timer control register (TCR). For details, refer to section 10.3.4, Timer Control Register (TCR).

3.3 Operating Mode Descriptions

3.3.1 Mode 2

The CPU can access a 16-Mbyte address space in advanced single-chip mode. The on-chip ROM is enabled.

3.3.2 Mode 3

The CPU can access a 64-Kbyte address space in normal single-chip mode. The on-chip ROM is enabled. The CPU can access a 56-kbyte address space in mode 3.

3.4 Address Map

Figures 3.1 and 3.2 show the address map in each operating mode.

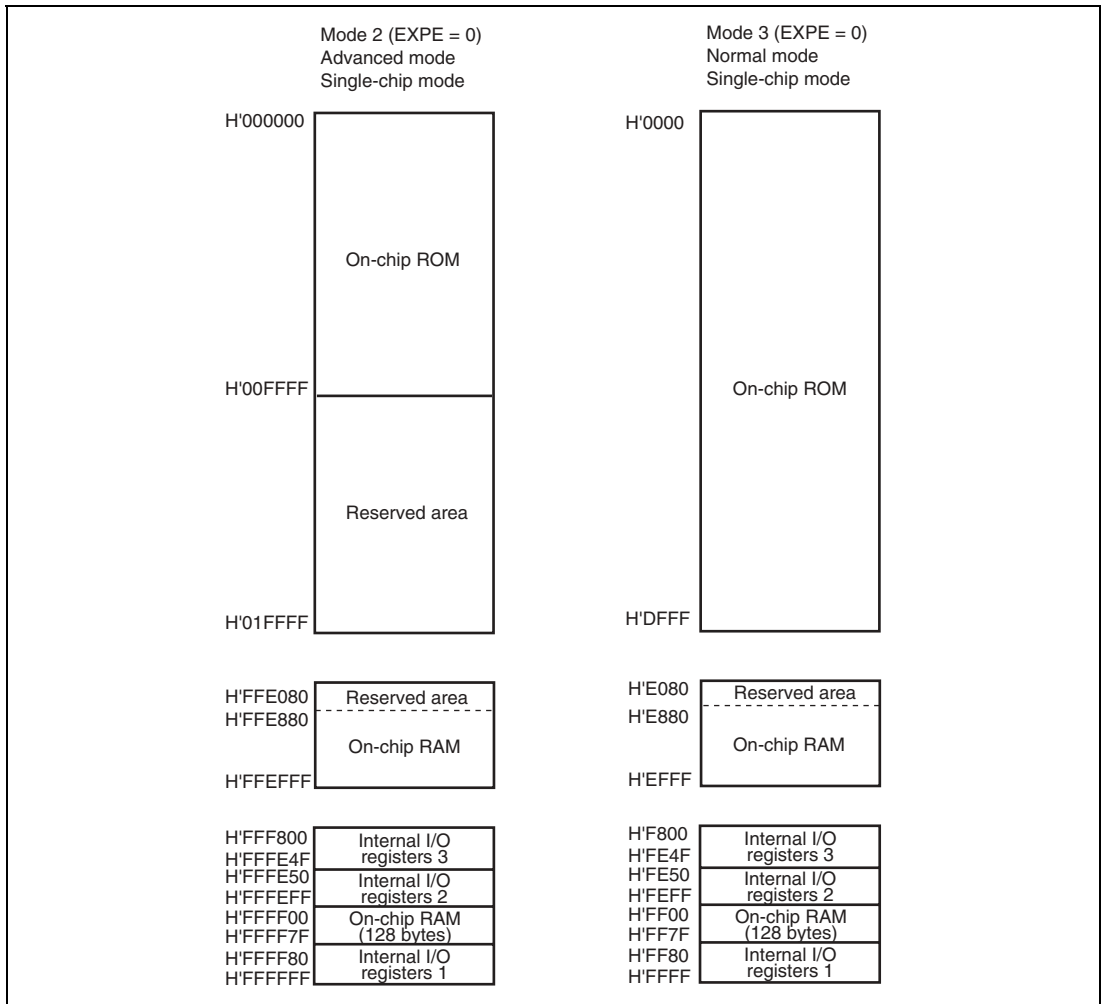

Figure 3.1 Address Map for H8S/2111B-B

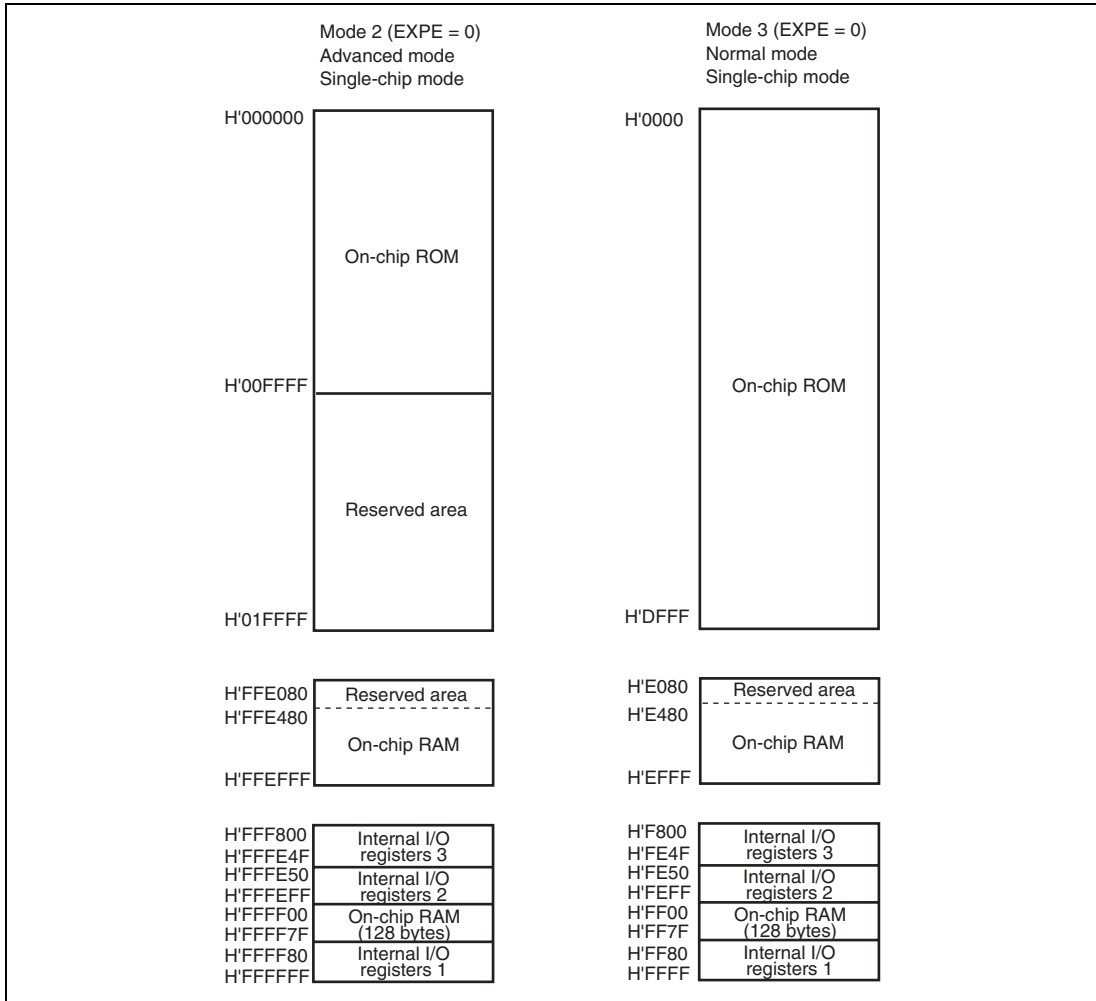

Figure 3.2 Address Map for H8S/2111B-C

Section 4 Exception Handling

4.1 Exception Handling Types and Priority

As table 4.1 indicates, exception handling may be caused by a reset, interrupt, direct transition, or trap instruction. Exception handling is prioritized as shown in table 4.1. If two or more exceptions occur simultaneously, they are accepted and processed in order of priority.

Table 4.1 Exception Types and Priority

Priority	Exception Type	Start of Exception Handling
High ↑ Low	Reset	Starts immediately after a low-to-high transition of the $\overline{\text{RES}}$ pin, or when the watchdog timer overflows.
	Interrupt	Starts when execution of the current instruction or exception handling ends, if an interrupt request has been issued. Interrupt detection is not performed on completion of ANDC, ORC, XORC, or LDC instruction execution, or on completion of reset exception handling.
	Direct transition	Starts when a direction transition occurs as the result of SLEEP instruction execution.
	Trap instruction	Started by execution of a trap (TRAPA) instruction. Trap instruction exception handling requests are accepted at all times in program execution state.

4.2 Exception Sources and Exception Vector Table

Different vector addresses are assigned to different exception sources. Table 4.2 lists the exception sources and their vector addresses.

Table 4.2 Exception Handling Vector Table

Exception Source	Vector Number	Vector Address		
		Normal Mode	Advanced Mode	
Reset	0	H'0000 to H'0001	H'000000 to H'000003	
Reserved for system use	1	H'0002 to H'0003	H'000004 to H'000007	
	5	H'000A to H'000B	H'000014 to H'000017	
Direct transition	6	H'000C to H'000D	H'000018 to H'00001B	
External interrupt (NMI)	7	H'000E to H'000F	H'00001C to H'00001F	
Trap instruction (four sources)	8	H'0010 to H'0011	H'000020 to H'000023	
	9	H'0012 to H'0013	H'000024 to H'000027	
	10	H'0014 to H'0015	H'000028 to H'00002B	
	11	H'0016 to H'0017	H'00002C to H'00002F	
Reserved for system use	12	H'0018 to H'0019	H'000030 to H'000033	
	15	H'001E to H'001F	H'00003C to H'00003F	
External interrupt	IRQ0	16	H'0020 to H'0021	H'000040 to H'000043
	IRQ1	17	H'0022 to H'0023	H'000044 to H'000047
	IRQ2	18	H'0024 to H'0025	H'000048 to H'00004B
	IRQ3	19	H'0026 to H'0027	H'00004C to H'00004F
	IRQ4	20	H'0028 to H'0029	H'000050 to H'000053
	IRQ5	21	H'002A to H'002B	H'000054 to H'000057
	IRQ6	22	H'002C to H'002D	H'000058 to H'00005B
	IRQ7	23	H'002E to H'002F	H'00005C to H'00005F
Internal interrupt*	24	H'0030 to H'0031	H'000060 to H'000063	
	111	H'00DE to H'00DF	H'0001BC to H'0001BF	

Note: * For details on the internal interrupt vector table, see section 5.5, Interrupt Exception Handling Vector Table.

4.3 Reset

A reset has the highest exception priority. When the $\overline{\text{RES}}$ pin goes low, all processing halts and this LSI enters the reset. To ensure that this LSI is reset, hold the $\overline{\text{RES}}$ pin low for at least 20 ms at power-on. To reset the chip during operation, hold the $\overline{\text{RES}}$ pin low for at least 20 states. A reset initializes the internal state of the CPU and the registers of on-chip peripheral modules. The chip can also be reset by overflow of the watchdog timer. For details, see section 11, Watchdog Timer (WDT).

4.3.1 Reset Exception Handling

When the $\overline{\text{RES}}$ pin goes high after being held low for the necessary time, this LSI starts reset exception handling as follows:

1. The internal state of the CPU and the registers of the on-chip peripheral modules are initialized and the I bit is set to 1 in CCR.
2. The reset exception handling vector address is read and transferred to the PC, and program execution starts from the address indicated by the PC.

Figure 4.1 shows an example of the reset sequence.

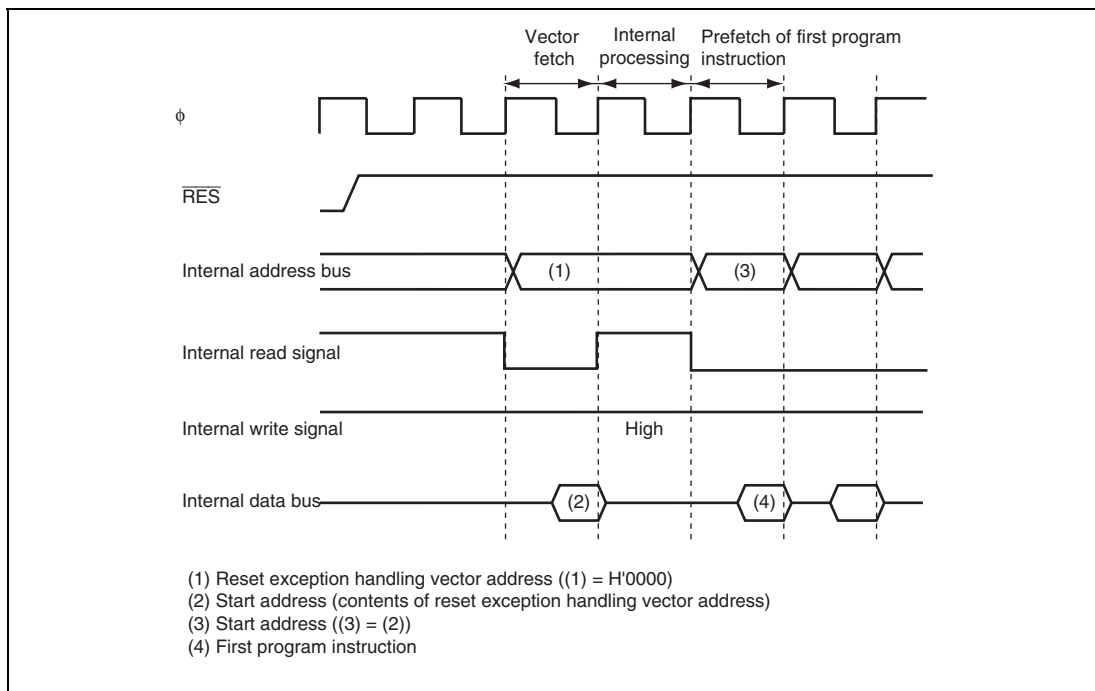

Figure 4.1 Reset Sequence (Mode 3)

4.3.2 Interrupts after Reset

If an interrupt is accepted after a reset and before the stack pointer (SP) is initialized, the PC and CCR will not be saved correctly, leading to a program crash. To prevent this, all interrupt requests, including NMI, are disabled immediately after a reset. Since the first instruction of a program is always executed immediately after the reset state ends, make sure that this instruction initializes the stack pointer (example: `MOV.L #xx: 32, SP`).

4.3.3 On-Chip Peripheral Modules after Reset is Cancelled

After a reset is cancelled, the module stop control registers (MSTPCR) are initialized, and all modules operate in module stop mode. Therefore, the registers of on-chip peripheral modules cannot be read from or written to. To read from and write to these registers, clear module stop mode.

4.4 Interrupt Exception Handling

Interrupts are controlled by the interrupt controller. The sources to start interrupt exception handling are external interrupt sources (NMI, IRQ7 to IRQ0, KIN15 to KIN0, and WUE7 to WUE0) and internal interrupt sources from the on-chip peripheral modules. NMI is an interrupt with the highest priority. For details, refer to section 5, Interrupt Controller.

Interrupt exception handling is conducted as follows:

1. The values in the program counter (PC) and condition code register (CCR) are saved to the stack.
2. A vector address corresponding to the interrupt source is generated, the start address is loaded from the vector table to the PC, and program execution begins from that address.

4.5 Trap Instruction Exception Handling

Trap instruction exception handling starts when a TRAPA instruction is executed. Trap instruction exception handling can be executed at all times in the program execution state.

Trap instruction exception handling is conducted as follows:

1. The values in the program counter (PC) and condition code register (CCR) are saved to the stack.
2. A vector address corresponding to the interrupt source is generated, the start address is loaded from the vector table to the PC, and program execution starts from that address.

The TRAPA instruction fetches a start address from a vector table entry corresponding to a vector number from 0 to 3, as specified in the instruction code.

Table 4.3 shows the status of CCR after execution of trap instruction exception handling.

Table 4.3 Status of CCR after Trap Instruction Exception Handling

Interrupt Control Mode	CCR	
	I	UI
0	1	—
1	1	1

[Legend]

1: Set to 1

—: Retains value prior to execution

4.6 Stack Status after Exception Handling

Figure 4.2 shows the stack after completion of trap instruction exception handling and interrupt exception handling.

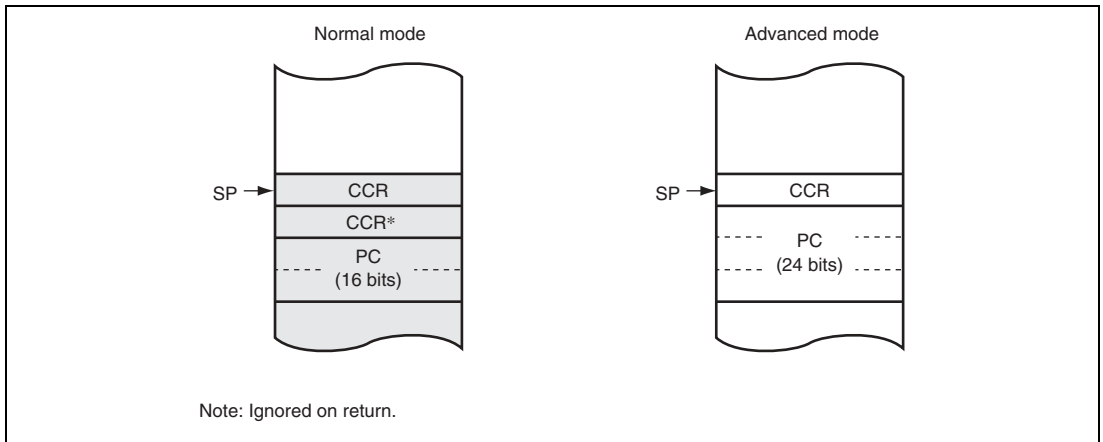

Figure 4.2 Stack Status after Exception Handling

4.7 Usage Note

When accessing word data or longword data, this LSI assumes that the lowest address bit is 0. The stack should always be accessed in words or longwords, and the value of the stack pointer (SP: ER7) should always be kept even.

Use the following instructions to save registers:

```
PUSH.W   Rn      (or MOV.W Rn, @-SP)
PUSH.L   ERn     (or MOV.L ERn, @-SP)
```

Use the following instructions to restore registers:

```
POP.W    Rn      (or MOV.W @SP+, Rn)
POP.L    ERn     (or MOV.L @SP+, ERn)
```

Setting SP to an odd value may lead to a malfunction. Figure 4.3 shows an example of what happens when the SP value is odd.

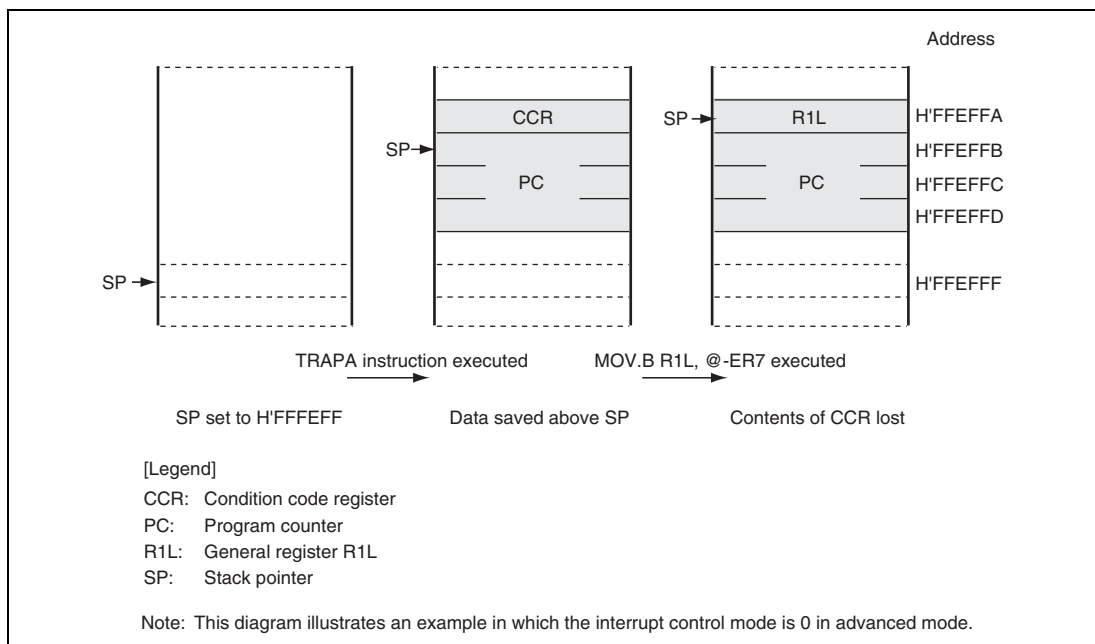

Figure 4.3 Operation when SP Value is Odd

Section 5 Interrupt Controller

5.1 Features

- Two interrupt control modes

Any of two interrupt control modes can be set by means of the INTM1 and INTM0 bits in the system control register (SYSCR).

- Priorities settable with ICR

An interrupt control register (ICR) is provided for setting interrupt priorities. Three priority levels can be set for each module for all interrupts except NMI and address break.

- Independent vector addresses

All interrupt sources are assigned independent vector addresses, making it unnecessary for the source to be identified in the interrupt handling routine.

- Thirty-one external interrupts

NMI is the highest-priority interrupt, and is accepted at all times. Rising edge or falling edge detection can be selected for NMI. Falling-edge, rising-edge, or both-edge detection, or level sensing, can be selected for $\overline{\text{IRQ7}}$ to $\overline{\text{IRQ0}}$. The IRQ6 interrupt is shared by the interrupt from the $\overline{\text{IRQ6}}$ pin and eight external interrupt inputs ($\overline{\text{KIN7}}$ to $\overline{\text{KIN0}}$), and the IRQ7 interrupt is shared by the interrupt from the $\overline{\text{IRQ7}}$ pin and sixteen external interrupt inputs ($\overline{\text{KIN15}}$ to $\overline{\text{KIN8}}$ and $\overline{\text{WUE7}}$ to $\overline{\text{WUE0}}$). $\overline{\text{KIN15}}$ to $\overline{\text{KIN0}}$ and $\overline{\text{WUE7}}$ to $\overline{\text{WUE0}}$ can be masked individually by the user program.

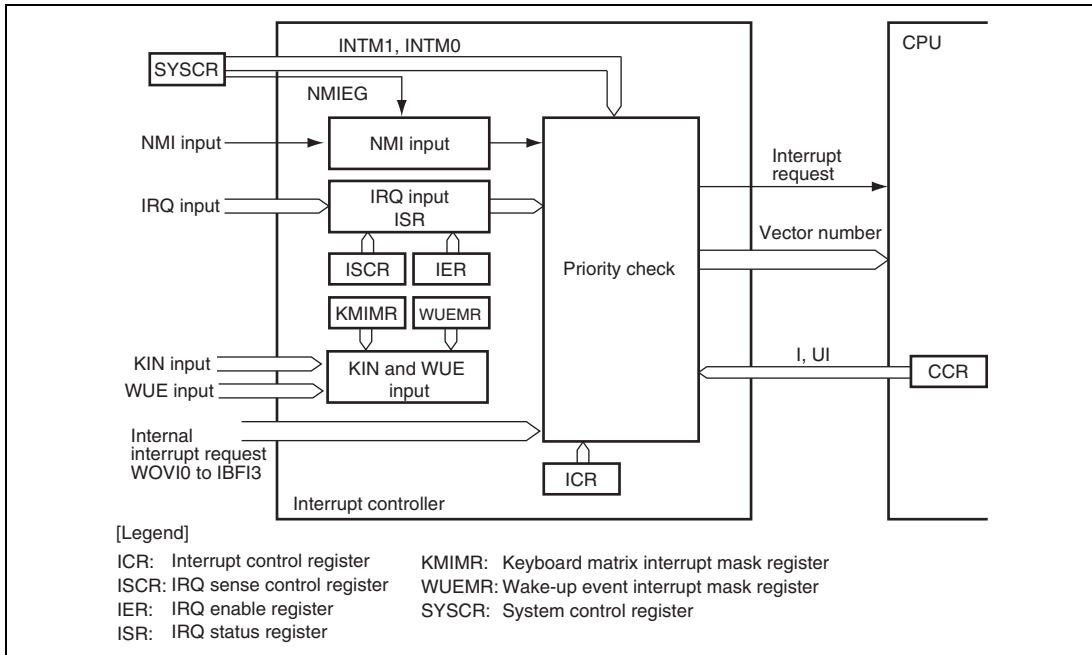

Figure 5.1 Block Diagram of Interrupt Controller

5.2 Input/Output Pins

Table 5.1 summarizes the pins of the interrupt controller.

Table 5.1 Pin Configuration

Symbol	I/O	Function
NMI	Input	Nonmaskable external interrupt Rising edge or falling edge can be selected
IRQ7 to IRQ0	Input	Maskable external interrupts Rising edge, falling edge, both edges, or level sensing, can be selected individually for each pin.
KIN15 to KIN0	Input	Maskable external interrupts Falling edge or level sensing can be selected.
WUE7 to WUE0	Input	Maskable external interrupts Falling edge or level sensing can be selected.

5.3 Register Descriptions

The interrupt controller has the following registers. For details on the system control register (SYSCR), refer to section 3.2.2, System Control Register (SYSCR).

- Interrupt control registers A to C (ICRA to ICRC)
- Address break control register (ABRKCR)
- Break address registers A to C (BARA to BARC)
- IRQ sense control registers (ISCRH, ISCRL)
- IRQ enable register (IER)
- IRQ status register (ISR)
- Keyboard matrix interrupt mask registers (KMIMRA, KMIMR)
- Wake-up event interrupt mask register (WUEMRB)

5.3.1 Interrupt Control Registers A to C (ICRA to ICRC)

The ICR registers set interrupt control levels for interrupts other than NMI and address breaks.

The correspondence between interrupt sources and ICRA to ICRC settings is shown in table 5.2.

Bit	Bit Name	Initial Value	R/W	Description
7 to 0	ICRn7 to IRCn0	All 0	R/W	Interrupt Control Level 0: Corresponding interrupt source is interrupt control level 0 (no priority) 1: Corresponding interrupt source is interrupt control level 1 (priority)

[Legend]

n: A to C

Table 5.2 Correspondence between Interrupt Source and ICR

Bit	Bit Name	Register		
		ICRA	ICRB	ICRC
7	ICRn7	IRQ0	—	—
6	ICRn6	IRQ1	FRT	SCI_1
5	ICRn5	IRQ2, IRQ3	—	—
4	ICRn4	IRQ4, IRQ5	—	IIC_0
3	ICRn3	IRQ6, IRQ7	TMR_0	IIC_1
2	ICRn2	—	TMR_1	TMR_A, TMR_B
1	ICRn1	WDT_0	TMR_X, TMR_Y	LPC
0	ICRn0	WDT_1	Keyboard buffer controller	—

[Legend]

n: A to C

—: Reserved. The write value should always be 0.

5.3.2 Address Break Control Register (ABRKCR)

ABRKCR controls the address breaks. When both the CMF flag and BIE flag are set to 1, an address break is requested.

Bit	Bit Name	Initial Value	R/W	Description
7	CMF	0	R	Condition Match Flag Address break source flag. Indicates that an address specified by BARA to BARC is prefetched. [Setting condition] When an address specified by BARA to BARC is prefetched while the BIE flag is set to 1. [Clearing condition] When an exception handling is executed for an address break interrupt.
6 to 1	—	All 0	R	Reserved These bits are always read as 0 and cannot be modified.
0	BIE	0	R/W	Break Interrupt Enable Enables or disables address break. 0: Disabled 1: Enabled

5.3.3 Break Address Registers A to C (BARA to BARC)

The BAR registers specify an address that is to be a break address. An address in which the first byte of an instruction exists should be set as a break address. In normal mode, addresses A23 to A16 are not compared.

- BARA

Bit	Bit Name	Initial Value	R/W	Description
7 to 0	A23 to A16	All 0	R/W	Addresses 23 to 16 The A23 to A16 bits are compared with A23 to A16 in the internal address bus.

- BARB

Bit	Bit Name	Initial Value	R/W	Description
7 to 0	A15 to A8	All 0	R/W	Addresses 15 to 8 The A15 to A8 bits are compared with A15 to A8 in the internal address bus.

- BARC

Bit	Bit Name	Initial Value	R/W	Description
7 to 1	A7 to A1	All 0	R/W	Addresses 7 to 1 The A7 to A1 bits are compared with A7 to A1 in the internal address bus.
0	—	0	R	Reserved This bit is always read as 0 and cannot be modified.

5.3.4 IRQ Sense Control Registers (ISCRH, ISCRL)

The ISCR registers select the source that generates an interrupt request at pins $\overline{\text{IRQ7}}$ to $\overline{\text{IRQ0}}$.

- ISCRH

Bit	Bit Name	Initial Value	R/W	Description
7	IRQ7SCB	0	R/W	IRQn Sense Control B
6	IRQ7SCA	0	R/W	IRQn Sense Control A
5	IRQ6SCB	0	R/W	00: Interrupt request generated at low level of $\overline{\text{IRQn}}$ input
4	IRQ6SCA	0	R/W	01: Interrupt request generated at falling edge of $\overline{\text{IRQn}}$ input
3	IRQ5SCB	0	R/W	10: Interrupt request generated at rising edge of $\overline{\text{IRQn}}$ input
2	IRQ5SCA	0	R/W	11: Interrupt request generated at both falling and rising edges of $\overline{\text{IRQn}}$ input
1	IRQ4SCB	0	R/W	
0	IRQ4SCA	0	R/W	

(n = 7 to 4)

- ISCRL

Bit	Bit Name	Initial Value	R/W	Description
7	IRQ3SCB	0	R/W	IRQn Sense Control B
6	IRQ3SCA	0	R/W	IRQn Sense Control A
5	IRQ2SCB	0	R/W	00: Interrupt request generated at low level of $\overline{\text{IRQn}}$ input
4	IRQ2SCA	0	R/W	01: Interrupt request generated at falling edge of $\overline{\text{IRQn}}$ input
3	IRQ1SCB	0	R/W	10: Interrupt request generated at rising edge of $\overline{\text{IRQn}}$ input
2	IRQ1SCA	0	R/W	11: Interrupt request generated at both falling and rising edges of $\overline{\text{IRQn}}$ input
1	IRQ0SCB	0	R/W	
0	IRQ0SCA	0	R/W	

(n = 3 to 0)

5.3.5 IRQ Enable Register (IER)

IER controls the enabling and disabling of interrupt requests IRQ7 to IRQ0.

Bit	Bit Name	Initial Value	R/W	Description
7	IRQ7E	0	R/W	IRQn Enable (n = 7 to 0)
6	IRQ6E	0	R/W	The IRQn interrupt request is enabled when this bit is 1.
5	IRQ5E	0	R/W	
4	IRQ4E	0	R/W	
3	IRQ3E	0	R/W	
2	IRQ2E	0	R/W	
1	IRQ1E	0	R/W	
0	IRQ0E	0	R/W	

5.3.6 IRQ Status Register (ISR)

The ISR register is a flag register that indicates the status of IRQ7 to IRQ0 interrupt requests.

Bit	Bit Name	Initial Value	R/W	Description
7	IRQ7F	0	R/(W)*	[Setting condition]
6	IRQ6F	0	R/(W)*	When the interrupt source selected by the ISCR registers occurs
5	IRQ5F	0	R/(W)*	
4	IRQ4F	0	R/(W)*	[Clearing conditions]
3	IRQ3F	0	R/(W)*	When reading IRQnF flag when IRQnF = 1, then writing 0 to IRQnF flag
2	IRQ2F	0	R/(W)*	
1	IRQ1F	0	R/(W)*	When interrupt exception handling is executed when low-level detection is set and $\overline{\text{IRQn}}$ input is high (n = 7 to 0)
0	IRQ0F	0	R/(W)*	

When IRQn interrupt exception handling is executed when falling-edge, rising-edge, or both-edge detection is set

Note: * Only 0 can be written, for flag clearing.

5.3.7 Keyboard Matrix Interrupt Mask Registers (KMIMRA, KMIMR) Wake-Up Event Interrupt Mask Register (WUEMRB)

The KMIMRA, KMIMR, and WUEMRB registers enable or disable key-sensing interrupt inputs ($\overline{\text{KIN15}}$ to $\overline{\text{KIN0}}$), and wake-up event interrupt inputs ($\overline{\text{WUE7}}$ to $\overline{\text{WUE0}}$).

- KMIMRA

Bit	Bit Name	Initial Value	R/W	Description
7	KMIMR15	1	R/W	Keyboard Matrix Interrupt Mask 15 to 8
6	KMIMR14	1	R/W	These bits enable or disable a key-sensing input interrupt request (KIN15 to KIN8).
5	KMIMR13	1	R/W	
4	KMIMR12	1	R/W	0: Enables a key-sensing input interrupt request
3	KMIMR11	1	R/W	1: Disables a key-sensing input interrupt request
2	KMIMR10	1	R/W	
1	KMIMR9	1	R/W	
0	KMIMR8	1	R/W	

- KMIMR

Bit	Bit Name	Initial Value	R/W	Description
7	KMIMR7	1	R/W	Keyboard Matrix Interrupt Mask 7 to 0
6	KMIMR6	0	R/W	These bits enable or disable a key-sensing input interrupt request (KIN7 to KIN0).
5	KMIMR5	1	R/W	
4	KMIMR4	1	R/W	KMIMR6 also performs interrupt request mask control for pin IRQ6.
3	KMIMR3	1	R/W	0: Enables a key-sensing input interrupt request 1: Disables a key-sensing input interrupt request
2	KMIMR2	1	R/W	
1	KMIMR1	1	R/W	
0	KMIMR0	1	R/W	

- WUEMRB

Bit	Bit Name	Initial Value	R/W	Description
7	WUEMR7	1	R/W	Wake-Up Event Interrupt Mask 7 to 0
6	WUEMR6	1	R/W	These bits enable or disable a wake-up event input interrupt request (WUE7 to WUE0).
5	WUEMR5	1	R/W	
4	WUEMR4	1	R/W	0: Enables a wake-up event input interrupt request
3	WUEMR3	1	R/W	1: Disables a wake-up event input interrupt request
2	WUEMR2	1	R/W	
1	WUEMR1	1	R/W	
0	WUEMR0	1	R/W	

Figure 5.2 shows the relationship between interrupts $\overline{\text{IRQ7}}$ and $\overline{\text{IRQ6}}$, interrupts KIN15 to KIN0 , interrupts WUE7 to WUE0 , and registers KMIMRA , KMIMR , and WUEMRB .

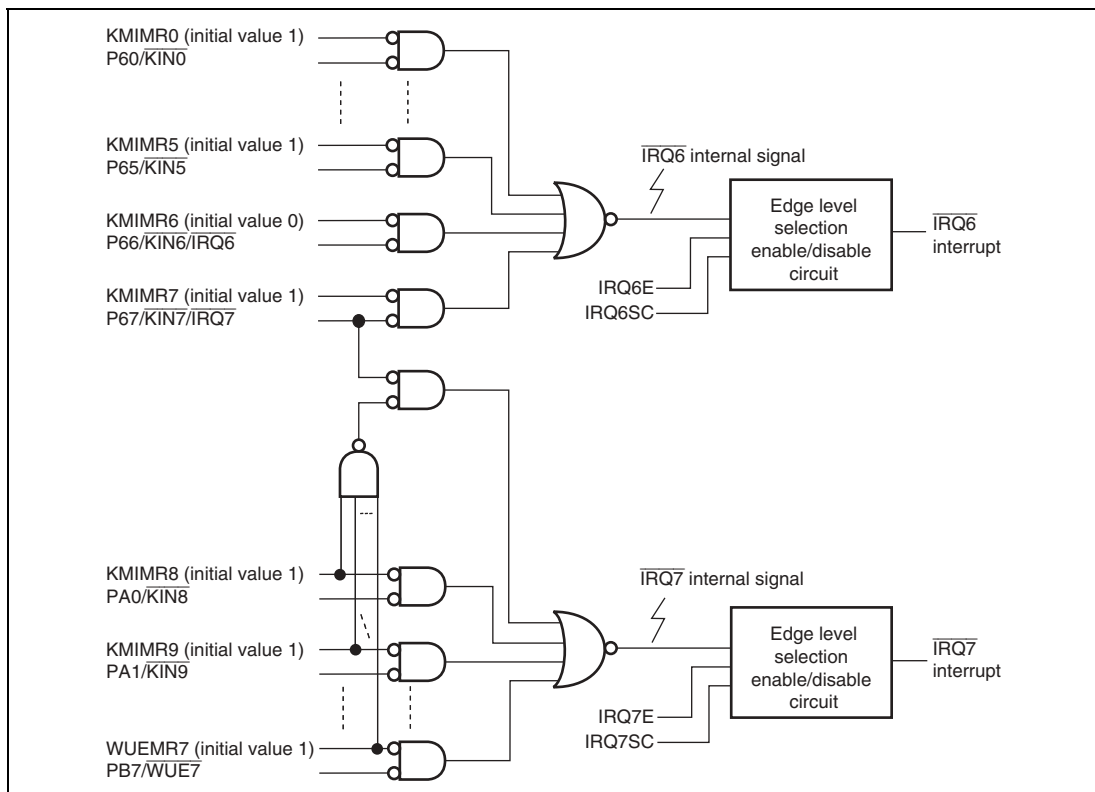

Figure 5.2 Relationship between Interrupts $\overline{\text{IRQ7}}$ and $\overline{\text{IRQ6}}$, Interrupts KIN15 to KIN0 , Interrupts WUE7 to WUE0 , and Registers KMIMR , KMIMRA , and WUEMRB

If any of bits KMIMR15 to KMIMR8 or WUEMRB7 to WUEMRB0 is cleared to 0, interrupt input from the $\overline{\text{IRQ7}}$ pin will be ignored. When pins $\overline{\text{KIN7}}$ to $\overline{\text{KIN0}}$, $\overline{\text{KIN15}}$ to $\overline{\text{KIN8}}$, or $\overline{\text{WUE7}}$ to $\overline{\text{WUE0}}$ are used as key-sense interrupt input pins or wakeup event interrupt input pins, either low-level sensing or falling-edge sensing must be designated as the interrupt sense condition for the corresponding interrupt source ($\overline{\text{IRQ6}}$ or $\overline{\text{IRQ7}}$).

5.4 Interrupt Sources

5.4.1 External Interrupts

There are four types of external interrupts: NMI, IRQ7 to IRQ0, KIN15 to KIN0 and WUE7 to WUE0. WUE7 to WUE0 and KIN15 to KIN8 share the IRQ7 interrupt source, and KIN7 to KIN0 share the IRQ6 interrupt source. Of these, NMI, IRQ7, IRQ6, and IRQ2 to IRQ0 can be used to restore this LSI from software standby mode.

NMI Interrupt: NMI is the highest-priority interrupt, and is always accepted by the CPU regardless of the interrupt control mode or the status of the CPU interrupt mask bits. The NMIEG bit in SYSCR can be used to select whether an interrupt is requested at a rising edge or a falling edge on the NMI pin.

IRQ7 to IRQ0 Interrupts: Interrupts IRQ7 to IRQ0 are requested by an input signal at pins $\overline{\text{IRQ7}}$ to $\overline{\text{IRQ0}}$. Interrupts IRQ7 to IRQ0 have the following features:

- The interrupt exception handling for interrupt requests IRQ7 to IRQ0 can be started at an independent vector address.
- Using ISCR, it is possible to select whether an interrupt is generated by a low level, falling edge, rising edge, or both edges, at pins $\overline{\text{IRQ7}}$ to $\overline{\text{IRQ0}}$.
- Enabling or disabling of interrupt requests IRQ7 to IRQ0 can be selected with IER.
- Interrupt control levels can be specified by the ICR settings.
- The status of interrupt requests IRQ7 to IRQ0 is indicated in ISR. ISR flags can be cleared to 0 by software.

The detection of IRQ7 to IRQ0 interrupts does not depend on whether the relevant pin has been set for input or output. However, when a pin is used as an external interrupt input pin, do not clear the corresponding DDR to 0 to use the pin as an I/O pin for another function.

A block diagram of interrupts IRQ7 to IRQ0 is shown in figure 5.3.

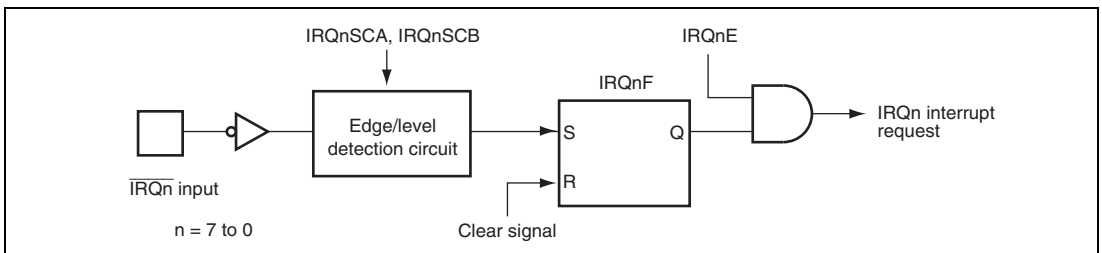

Figure 5.3 Block Diagram of Interrupts IRQ7 to IRQ0

When pin $\overline{\text{IRQ6}}$ is used as an IRQ6 interrupt input pin, clear the KMIMR6 bit to 0.

When pin $\overline{\text{IRQ7}}$ is used as an IRQ7 interrupt pin, set all of bits KMIMR15 to KMIMR8 and WUEMR7 to WUEMR0 to 1. If any of these bits is cleared to 0, IRQ7 interrupt input from the $\overline{\text{IRQ7}}$ pin will be ignored.

Since interrupt request flags IRQ7F to IRQ0F are set each time the setting condition is satisfied, regardless of the IER setting, refer to a needed flag only.

KIN15 to KIN0 Interrupts, WUE7 to WUE0 Interrupts: Interrupts KIN15 to KIN0 and WUE7 to WUE0 are requested by an input signal at pins $\overline{\text{KIN15}}$ to $\overline{\text{KIN0}}$ and $\overline{\text{WUE7}}$ to $\overline{\text{WUE0}}$. When pins $\overline{\text{KIN15}}$ to $\overline{\text{KIN0}}$ and $\overline{\text{WUE7}}$ to $\overline{\text{WUE0}}$ are used for key-sense input or wakeup event, clear the corresponding KMIMR and WUEMR bits to 0 in order to enable their key-sense input and wakeup event interrupts. Remaining unused KMIMR and WUEMR bits for key-sense input should be set to 1 in order to disable interrupts. Interrupts WUE7 to WUE0 and KIN15 to KIN8 generate IRQ7 interrupts, and interrupts KIN7 to KIN0 generate IRQ6 interrupts. The pin conditions for interrupt request generation, enable of interrupt requests, settings of interrupt control levels, and status display of interrupt requests depend on each setting and display of the IRQ7 or IRQ6 interrupt.

When pins $\overline{\text{KIN7}}$ to $\overline{\text{KIN0}}$, $\overline{\text{KIN15}}$ to $\overline{\text{KIN8}}$, or $\overline{\text{WUE7}}$ to $\overline{\text{WUE0}}$ are used as key-sense interrupt input pins or wakeup event interrupt input pins, either low-level sensing or falling-edge sensing must be designated as the interrupt sense condition for the corresponding interrupt source (IRQ6 or IRQ7).

5.4.2 Internal Interrupts

Internal interrupts issued from the on-chip peripheral modules have the following features:

1. For each on-chip peripheral module there are flags that indicate the interrupt request status, and enable bits that individually select enabling or disabling of these interrupts. When the enable bit for a particular interrupt source is set to 1, an interrupt request is sent to the interrupt controller.
2. The control level for each interrupt can be set by ICR.

5.5 Interrupt Exception Handling Vector Table

Table 5.3 lists interrupt exception handling sources, vector addresses, and interrupt priorities. For default priorities, the lower the vector number, the higher the priority. Modules set at the same priority will conform to their default priorities. Priorities within a module are fixed.

An interrupt control level can be specified for a module to which an ICR bit is assigned. Interrupt requests from modules that are set to control level 1 (priority) by the ICR bit setting and the I and UI bits in CCR are given priority and processed before interrupt requests from modules that are set to control level 0 (no priority).

Table 5.3 Interrupt Sources, Vector Addresses, and Interrupt Priorities

Origin of Interrupt Source	Name	Vector Address			ICR	Priority
		Vector Number	Normal Mode	Advanced Mode		
External pin	NMI	7	H'000E	H'00001C	—	High ↑
	IRQ0	16	H'0020	H'000040	ICRA7	
	IRQ1	17	H'0022	H'000044	ICRA6	
	IRQ2	18	H'0024	H'000048	ICRA5	
	IRQ3	19	H'0026	H'00004C		
	IRQ4	20	H'0028	H'000050	ICRA4	
	IRQ5	21	H'002A	H'000054		
	IRQ6, KIN7 to KIN0 IRQ7, KIN15 to KIN8, WUE7 to WUE0	22 23	H'002C H'002E	H'000058 H'00005C	ICRA3	
—	Reserved for system use	24	H'0030	H'000060	—	
WDT_0	WOVI0 (Interval timer)	25	H'0032	H'000064	ICRA1	
WDT_1	WOVI1 (Interval timer)	26	H'0034	H'000068	ICRA0	
—	Address break	27	H'0036	H'00006C	—	
—	Reserved for system use	28 to 47	H'0038 to H'005E	H'000070 to H'0000BC	—	
FRT	ICIA (Input capture A)	48	H'0060	H'0000C0	ICRB6	
	ICIB (Input capture B)	49	H'0062	H'0000C4		
	ICIC (Input capture C)	50	H'0064	H'0000C8		
	ICID (Input capture D)	51	H'0066	H'0000CC		
	OCIA (Output compare A)	52	H'0068	H'0000D0		
	OCIB (Output compare B)	53	H'006A	H'0000D4		
	FOV1 (Overflow)	54	H'006C	H'0000D8		
	Reserved for system use	55	H'006E	H'0000DC		
—	Reserved for system use	56 to 63	H'0070 to H'007E	H'0000E0 to H'0000FC	—	
						Low

Origin of Interrupt Source	Name	Vector Address			ICR	Priority
		Vector Number	Normal Mode	Advanced Mode		
TMR_0	CMIA0 (Compare match A)	64	H'0080	H'000100	ICRB3	High ↑
	CMIB0 (Compare match A)	65	H'0082	H'000104		
	OVI0 (Overflow)	66	H'0084	H'000108		
	Reserved for system use	67	H'0086	H'00010C		
TMR_1	CMIA1 (Compare match A)	68	H'0088	H'000110	ICRB2	
	CMIB1 (Compare match B)	69	H'008A	H'000114		
	OVI1 (Overflow)	70	H'008C	H'000118		
	Reserved for system use	71	H'008E	H'00011C		
TMR_X, TMR_Y	CMIA Y (Compare match A)	72	H'0090	H'000120	ICRB1	
	CMIB Y (Compare match B)	73	H'0092	H'000124		
	OVI Y (Overflow)	74	H'0094	H'000128		
	ICIX (Input capture X)	75	H'0096	H'00012C		
—	Reserved for system use	76	H'0098	H'000130	—	
		to	to	to		
		83	H'00A6	H'00014C		
SCI_1	ERI1 (Reception error 1)	84	H'00A8	H'000150	ICRC6	
	RX11 (Reception completion 1)	85	H'00AA	H'000154		
	TX11 (Transmission data empty 1)	86	H'00AC	H'000158		
	TEI1 (Transmission end 1)	87	H'00AE	H'00015C		
—	Reserved for system use	88	H'00B0	H'000160	—	
		to	to	to		
		91	H'00B6	H'00016C		
IIC_0	IIC10 (1-byte transmission/ reception completion)	92	H'00B8	H'000170	ICRC4	
	Reserved for system use	93	H'00BA	H'000174		
IIC_1	IIC11 (1-byte transmission/ reception completion)	94	H'00BC	H'000178	ICRC3	
	Reserved for system use	95	H'00BE	H'00017C		
Keyboard buffer controller	KBIA (Reception completion A)	96	H'00C0	H'000180	ICRB0	
	KBIB (Reception completion B)	97	H'00C2	H'000184		
	KBIC (Reception completion C)	98	H'00C4	H'000188		
	Reserved for system use	99	H'00C6	H'00018C		
TMR_A, TMR_B	CMIAAB (Compare match A)	100	H'00C8	H'000190	ICRC2	
	CMIBAB (Compare match B)	101	H'00CA	H'000194		
	OVIAB (Overflow)	102	H'00CC	H'000198		
	ICIA (Input capture A)	103	H'00CE	H'00019C		
—	Reserved for system use	104	H'00D0	H'0001A0	—	
		to	to	to		
		107	H'00D6	H'0001AC		
LPC	ERR1 (Transfer error)	108	H'00D8	H'0001B0	ICRC1	
	IBF1 (IDR1 reception completion)	109	H'00DA	H'0001B4		
	IBF2 (IDR2 reception completion)	110	H'00DC	H'0001B8		
	IBF3 (IDR3 reception completion)	111	H'00DE	H'0001BC		

5.6 Interrupt Control Modes and Interrupt Operation

The interrupt controller has two modes: Interrupt control mode 0 and interrupt control mode 1. Interrupt operations differ depending on the interrupt control mode. NMI interrupts and address break interrupts are always accepted except for in reset state or in hardware standby mode. The interrupt control mode is selected by SYSCR. Table 5.4 shows the interrupt control modes.

Table 5.4 Interrupt Control Modes

Interrupt Control Mode	SYSCR		Priority Setting Registers	Interrupt Mask Bits	Description
	INTM1	INTM0			
0	0	0	ICR	I	Interrupt mask control is performed by the I bit. Priority levels can be set with ICR.
1		1	ICR	I, UI	3-level interrupt mask control is performed by the I bit. Priority levels can be set with ICR.

5.6.1 Interrupt Control Mode 0

In interrupt control mode 0, interrupt requests other than NMI and address breaks are masked by ICR and the I bit of the CCR in the CPU. Figure 5.4 shows a flowchart of the interrupt acceptance operation.

1. If an interrupt source occurs when the corresponding interrupt enable bit is set to 1, an interrupt request is sent to the interrupt controller.
2. According to the interrupt control level specified in ICR, the interrupt controller only accepts an interrupt request with interrupt control level 1 (priority), and holds pending an interrupt request with interrupt control level 0 (no priority). If several interrupt requests are issued, an interrupt request with the highest priority is accepted according to the priority order, an interrupt handling is requested to the CPU, and other interrupt requests are held pending.
3. If the I bit in CCR is set to 1, only NMI and address break interrupts are accepted by the interrupt controller, and other interrupt requests are held pending. If the I bit is cleared to 0, any interrupt request is accepted.
4. When the CPU accepts an interrupt request, it starts interrupt exception handling after execution of the current instruction has been completed.
5. The PC and CCR are saved to the stack area by interrupt exception handling. The PC saved on the stack shows the address of the first instruction to be executed after returning from the interrupt handling routine.
6. Next, the I bit in CCR is set to 1. This masks all interrupts except for NMI and address break interrupts.

7. The CPU generates a vector address for the accepted interrupt and starts execution of the interrupt handling routine at the address indicated by the contents of the vector address in the vector table.

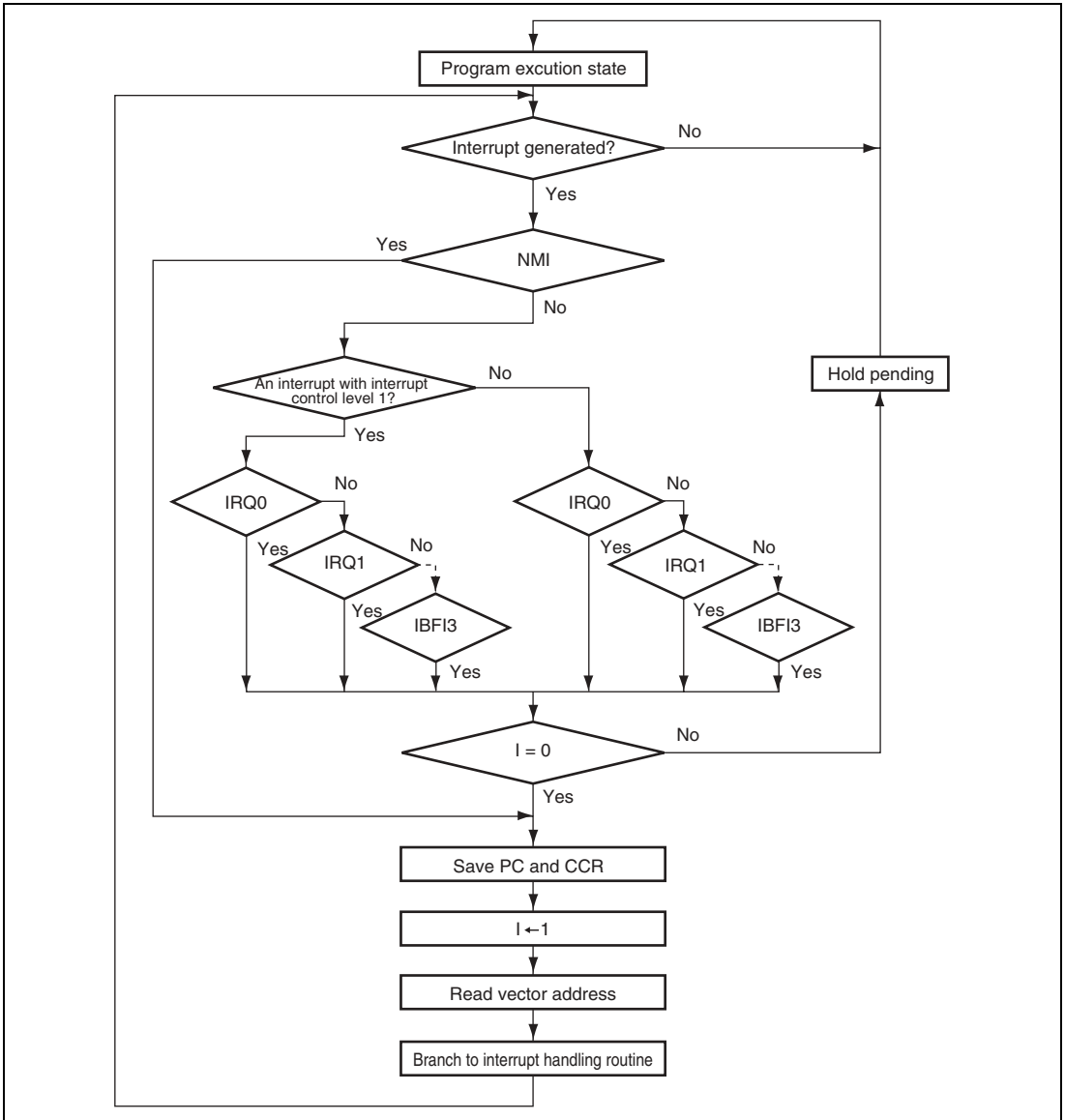

Figure 5.4 Flowchart of Procedure up to Interrupt Acceptance in Interrupt Control Mode 0

5.6.2 Interrupt Control Mode 1

In interrupt control mode 1, mask control is applied to three levels for IRQ and on-chip peripheral module interrupt requests by comparing the I and UI bits in CCR in the CPU, and the ICR setting.

- An interrupt request with interrupt control level 0 is accepted when the I bit in CCR is cleared to 0. When the I bit is set to 1, the interrupt request is held pending
- An interrupt request with interrupt control level 1 is accepted when the I bit or UI bit in CCR is cleared to 0. When both I and UI bits are set to 1, the interrupt request is held pending.

For instance, the state transition when the interrupt enable bit corresponding to each interrupt is set to 1, and ICRA to ICRC are set to H'20, H'00, and H'00, respectively (IRQ2 and IRQ3 interrupts are set to control level 1, and other interrupts are set to control level 0) is shown below. Figure 5.5 shows a state transition diagram.

- All interrupt requests are accepted when $I = 0$. (Priority order: NMI > IRQ2 > IRQ3 > address break > IRQ0 > IRQ1 ...)
- Only NMI, IRQ2, IRQ3 and address break interrupt requests are accepted when $I = 1$ and $UI = 0$.
- Only an NMI and address break interrupt request is accepted when $I = 1$ and $UI = 1$.

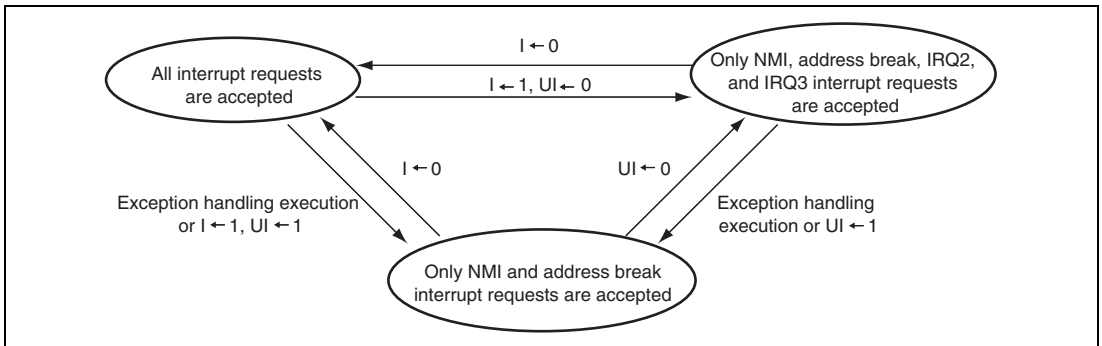

Figure 5.5 State Transition in Interrupt Control Mode 1

Figure 5.6 shows a flowchart of the interrupt acceptance operation.

1. If an interrupt source occurs when the corresponding interrupt enable bit is set to 1, an interrupt request is sent to the interrupt controller.
2. According to the interrupt control level specified in ICR, the interrupt controller only accepts an interrupt request with interrupt control level 1 (priority), and holds pending an interrupt request with interrupt control level 0 (no priority). If several interrupt requests are issued, an interrupt request with the highest priority is accepted according to the priority order, an interrupt handling is requested to the CPU, and other interrupt requests are held pending.
3. An interrupt request with interrupt control level 1 is accepted when the I bit is cleared to 0, or when the I bit is set to 1 while the UI bit is cleared to 0.
An interrupt request with interrupt control level 0 is accepted when the I bit is cleared to 0.
When the I bit is set to 1, only an NMI or address break interrupt request is accepted, and other interrupts are held pending.
When both the I and UI bits are set to 1, only an NMI or address break interrupt request is accepted, and other interrupts are held pending.
When the I bit is cleared to 0, the UI bit is not affected.
4. When the CPU accepts an interrupt request, it starts interrupt exception handling after execution of the current instruction has been completed.
5. The PC and CCR are saved to the stack area by interrupt exception handling. The PC saved on the stack shows the address of the first instruction to be executed after returning from the interrupt handling routine.
6. The I and UI bits in CCR are set to 1. This masks all interrupts except for an NMI or address break interrupt.
7. The CPU generates a vector address for the accepted interrupt and starts execution of the interrupt handling routine at the address indicated by the contents of the vector address in the vector table.

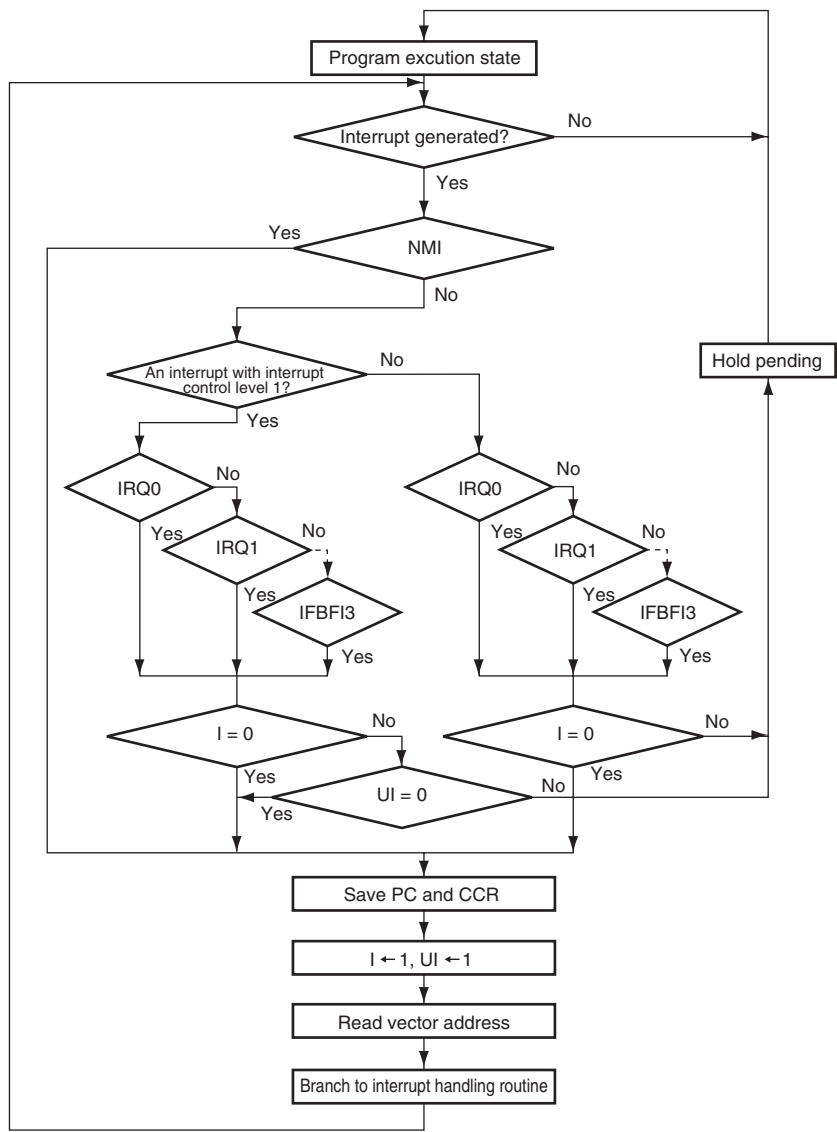

Figure 5.6 Flowchart of Procedure Up to Interrupt Acceptance in Interrupt Control Mode 1

5.6.3 Interrupt Exception Handling Sequence

Figure 5.7 shows the interrupt exception handling sequence. The example shown is for the case where interrupt control mode 0 is set in advanced mode, and the program area and stack area are in on-chip memory.

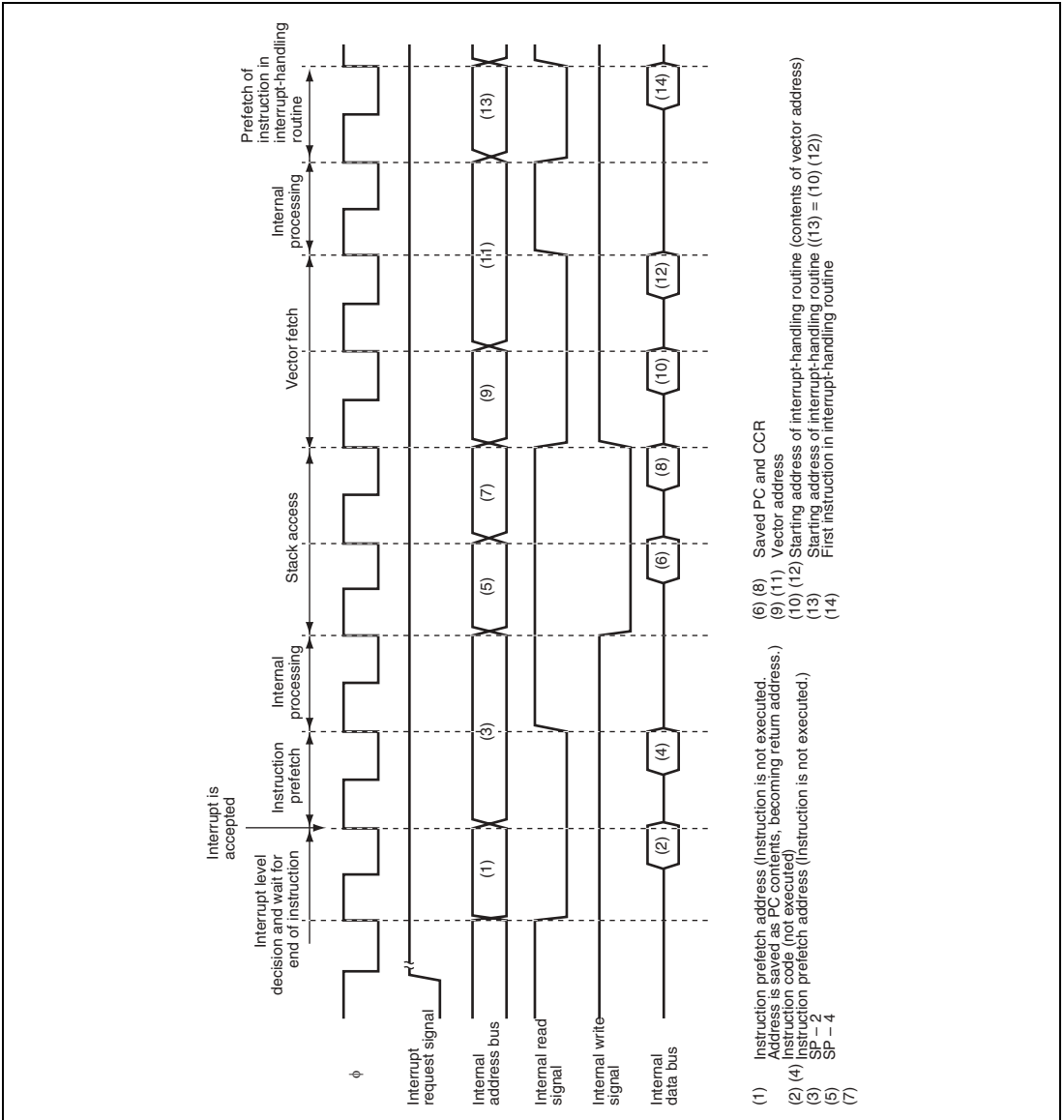

Figure 5.7 Interrupt Exception Handling

5.6.4 Interrupt Response Times

Table 5.5 shows interrupt response times – the intervals between generation of an interrupt request and execution of the first instruction in the interrupt handling routine. The execution status symbols used in table 5.5 are explained in table 5.6.

Table 5.5 Interrupt Response Times

No.	Execution Status	Normal Mode	Advanced Mode
1	Interrupt priority determination* ¹		3
2	Number of wait states until executing instruction ends* ²		1 to (19 + 2·S _I)
3	PC, CCR stack save	2·S _K	2·S _K
4	Vector fetch	S _I	2·S _I
5	Instruction fetch* ³		2·S _I
6	Internal processing* ⁴		2
	Total (using on-chip memory)	11 to 31	12 to 32

- Notes: 1. Two states in case of internal interrupt.
 2. Refers to MULXS and DIVXS instructions.
 3. Prefetch after interrupt acceptance and prefetch of interrupt handling routine.
 4. Internal processing after interrupt acceptance and internal processing after vector fetch.

Table 5.6 Number of States in Interrupt Handling Routine Execution Status

Symbol	Object of Access
	Internal Memory
Instruction fetch S _I	1
Branch address read S _J	
Stack manipulation S _K	

5.7 Address Break

5.7.1 Features

This LSI can determine the specific address prefetch by the CPU to generate an address break interrupt by setting ABRKCR and BAR. If an address break interrupt is generated, the address break interrupt exception handling is performed.

With this function, the execution start point of a program containing a bug is detected and execution is branched to the correcting program.

5.7.2 Block Diagram

Figure 5.8 shows a block diagram of the address break.

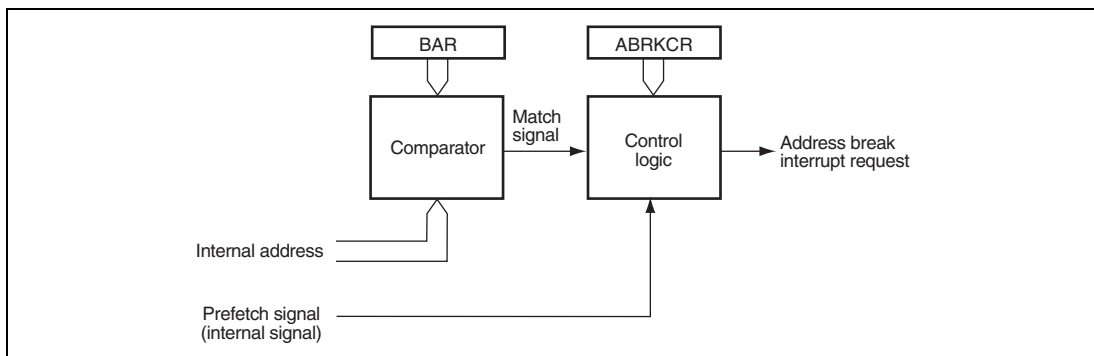

Figure 5.8 Address Break Block Diagram

5.7.3 Operation

If the CPU prefetches an address specified in BAR by setting ABRKCR and BAR, an address break interrupt can be generated. This address break function generates an interrupt request to the interrupt controller at prefetch, and determines the priority by the interrupt controller. When an interrupt is accepted, an interrupt exception handling is activated after the current instruction has been completed. Note that the interrupt mask control according to the I and UI bits in CCR of the CPU is invalid to an address break interrupt.

To use the address break function, set each register as follows:

1. Set a break address in the A23 to A1 bits in BAR.
2. Set the BIE bit in ABRKCR to 1 to enable the address break.
When the BIE bit is cleared to 0, an address break is not requested.

When the setting conditions are satisfied, the CMF flag in ABRKCR is set to 1 to request an interrupt. The interrupt source should be determined by the interrupt handling routine if necessary.

5.7.4 Usage Notes

1. In an address break, the break address should be an address where the first byte of the instruction exists. Otherwise, a break condition will not be satisfied.
2. In normal mode, addresses A23 to A16 are not compared.
3. When the branch instructions (Bcc, BSR), jump instructions (JMP, JSR), RST instruction, and RTE instruction are placed immediately prior to the address specified by BAR, a prefetch signal to the address may be output to request an address break by executing these instruction. It is necessary to take countermeasures: do not set a break address to an address immediately after these instructions, or determine whether interrupt handling is performed by satisfaction of a normal condition.
4. An address break interrupt is generated by combining the internal prefetch signal and an address. Therefore, the timing to enter the interrupt exception handling differs according to the instructions at the specified and at prior addresses and execution cycles.

Figure 5.9 shows an example of address timing.

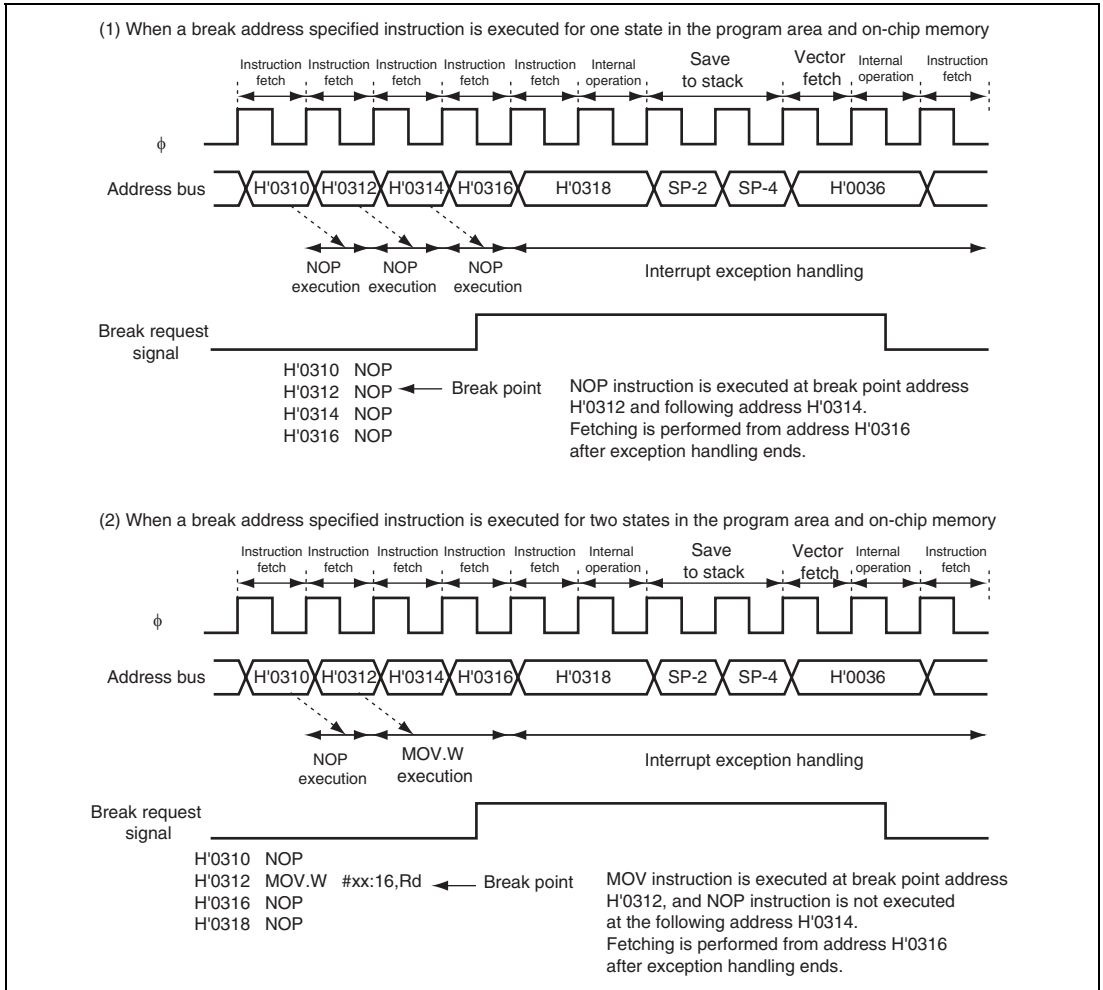

Figure 5.9 Address Break Timing Example

5.8 Usage Notes

5.8.1 Conflict between Interrupt Generation and Disabling

When an interrupt enable bit is cleared to 0 to disable interrupt requests, the disabling becomes effective after execution of the instruction. When an interrupt enable bit is cleared to 0 by an instruction such as BCLR or MOV, and if an interrupt is generated during execution of the instruction, the interrupt concerned will still be enabled on completion of the instruction, so interrupt exception handling for that interrupt will be executed on completion of the instruction. However, if there is an interrupt request of higher priority than that interrupt, interrupt exception handling will be executed for the higher-priority interrupt, and the lower-priority interrupt will be ignored. The same rule is also applied when an interrupt source flag is cleared to 0. Figure 5.10 shows an example in which the CMIEA bit in the TMR's TCR register is cleared to 0.

The above conflict will not occur if an enable bit or interrupt source flag is cleared to 0 while the interrupt is masked.

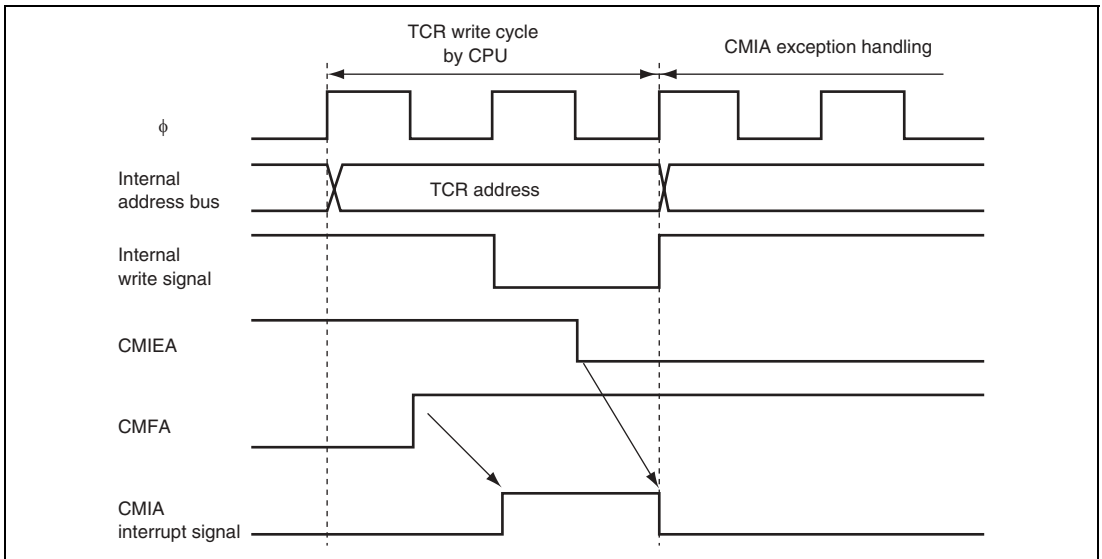

Figure 5.10 Conflict between Interrupt Generation and Disabling

5.8.2 Instructions that Disable Interrupts

The instructions that disable interrupts are LDC, ANDC, ORC, and XORC. After any of these instructions are executed, all interrupts including NMI are disabled and the next instruction is always executed. When the I bit or UI bit is set by one of these instructions, the new value becomes valid two states after execution of the instruction ends.

5.8.3 Interrupts during Execution of EEPMOV Instruction

Interrupt operation differs between the EEPMOV.B instruction and the EEPMOV.W instruction.

With the EEPMOV.B instruction, an interrupt request (including NMI) issued during the transfer is not accepted until the move is completed.

With the EEPMOV.W instruction, if an interrupt request is issued during the transfer, interrupt exception handling starts at a break in the transfer cycle. The PC value saved on the stack in this case is the address of the next instruction. Therefore, if an interrupt is generated during execution of an EEPMOV.W instruction, the following coding should be used.

```
L1:      EEPMOV.W
        MOV.W    R4, R4
        BNE     L1
```

5.8.4 IRQ Status Register (ISR)

According to the pin status after a reset, IRQnF may be set to 1, so ISR should be read after a reset to write 0. (n = 7 to 0)

Section 6 Bus Controller (BSC)

Since this LSI does not have an externally extended function, it does not have an on-chip bus controller (BSC). Considering the software compatibility with similar products, you must be careful to set appropriate values to the control registers for the bus controller.

6.1 Register Descriptions

The bus controller has the following registers.

- Bus control register (BCR)
- Wait state control register (WSCR)

6.1.1 Bus Control Register (BCR)

Bit	Bit Name	Initial Value	R/W	Description
7	—	1	R/W	Reserved The initial value should not be changed.
6	ICIS0	1	R/W	Idle Cycle Insertion The initial value should not be changed.
5	BRSTRM	0	R/W	Burst ROM Enable The initial value should not be changed.
4	BRSTS1	1	R/W	Burst Cycle Select 1 The initial value should not be changed.
3	BRSTS0	0	R/W	Burst Cycle Select 0 The initial value should not be changed.
2	—	0	R/W	Reserved The initial value should not be changed.
1	IOS1	1	R/W	IOS Select 1, 0
0	IOS0	1	R/W	The initial value should not be changed.

6.1.2 Wait State Control Register (WSCR)

Bit	Bit Name	Initial Value	R/W	Description
7	—	0	R/W	Reserved
6	—	0	R/W	The initial value should not be changed.
5	ABW	1	R/W	Bus Width Control The initial value should not be changed.
4	AST	1	R/W	Access State Control The initial value should not be changed.
3	WMS1	0	R/W	Wait Mode Select 1, 0
2	WMS0	0	R/W	The initial value should not be changed.
1	WC1	1	R/W	Wait Count 1, 0
0	WC0	1	R/W	The initial value should not be changed.

Section 7 I/O Ports

This LSI has fifteen I/O ports (ports 1 to 6, 8, 9, and A to G), and one input-only port (port 7).

Table 7.1 is a summary of the port functions. The pins of each port also have other functions.

Each port includes a data direction register (DDR) that controls input/output (not provided for the input-only port) and data registers (DR, ODR) that store output data.

Ports 1 to 3, 6, and A to F have on-chip input pull-up MOSs. For ports A to F, the on/off state of the input pull-up MOS is controlled by DDR and ODR. Ports 1 to 3 and 6 have DDR and an input pull-up MOS control register (PCR) to control the on/off state of the input pull-up MOS.

Ports 1 to 6, 8, 9, and A to F can drive a single TTL load and 30-pF capacitive load. All the I/O ports can drive a Darlington transistor when in output mode. Ports 1, 2, and 3 can drive an LED (10 mA sink current).

V_{ccB} , which is independent of the V_{cc} power supply, is supplied to Port A input/output. When the V_{ccB} voltage is 5 V, the pins on port A will be 5-V tolerant.

PA4 to PA7 of port A have bus-buffer drive capability.

P52 in port 5, P97 in port 9, P86 in port 8, P42 in port 4, and PG0 to PG 7 in port G are NMOS push-pull outputs. P52, P97, P86, P42, and PG0 to PG 7 are thus 5-V tolerant with DC characteristics dependent on the V_{cc} voltage.

For the P42, P52/ExSCK1, P86/SCK1, P97 outputs, and PG0 to PG7, connect pull-up resistors to pins to raise output-high-level voltage.

Table 7.1 Port Functions

Port	Description	Mode 2 and Mode 3	I/O Status
Port 1	General I/O port also functioning as PWM output pins	P17/PW7 P16/PW6 P15/PW5 P14/PW4 P13/PW3 P12/PW2 P11/PW1 P10/PW0	On-chip input pull-up MOSs
Port 2	General I/O port	P27 P26 P25 P24 P23 P22 P21 P20	On-chip input pull-up MOSs
Port 3	General I/O port also functioning as LPC input/output pins	P37/SERIRQ P36/LCLK P35/LRESET P34/LFRAME P33/LAD3 P32/LAD2 P31/LAD1 P30/LAD0	On-chip input pull-up MOSs
Port 4	General I/O port also functioning as TMR_0 and TMR_1 input/output, and IIC_1 input/output pins	P47 P46 P45/TMRI1 P44/TMO1 P43/TMCI1 P42/TMRI0/SDA1 P41/TMO0 P40/TMCI0	
Port 5	General I/O port also functioning as SCI_1 input/output and IIC_0 input/output pins	P52/ExSCK1*/SCL0 P51/ExRxD1* P50/ExTxD1*	

Port	Description	Mode 2 and Mode 3	I/O Status
Port 6	General I/O port also functioning as interrupt input, FRT input/output, TMR_X and TMR_Y input/output, and key-sense interrupt input	P67/TMOX/KIN7/IRQ7 P66/FTOB/KIN6/IRQ6 P65/FTID/KIN5 P64/FTIC/KIN4 P63/FTIB/KIN3 P62/FTIA/KIN2/TMIY P61/FTOA/KIN1 P60/FTCI/KIN0/TMIX	On-chip input pull-up MOSs
Port 7	General input port also functioning as A/D converter analog input	P77 P76 P75/AN5 P74/AN4 P73/AN3 P72/AN2 P71/AN1 P70/AN0	
Port 8	General I/O port also functioning as interrupt input, SCI_1 input/output, LPC input/output, and IIC_1 input/output pins	P86/IRQ5/SCK1/SCL1 P85/IRQ4/RxD1 P84/IRQ3/TxD1 P83/LPCPD P82/CLKRUN P81/GA20 P80/PME	
Port 9	General I/O port also functioning as IIC_0 input/output, subclock input, ϕ output, interrupt input, and A/D converter external trigger input pins	P97/SDA0 P96/ ϕ /EXCL P95 P94 P93 P92/IRQ0 P91/IRQ1 P90/IRQ2/ADTRG	

Port	Description	Mode 2 and Mode 3	I/O Status
Port A	General I/O port also functioning as key-sense interrupt input and keyboard buffer controller input/output pins	PA7/ $\overline{\text{KIN15}}$ /PS2CD PA6/ $\overline{\text{KIN14}}$ /PS2CC PA5/ $\overline{\text{KIN13}}$ /PS2BD PA4/ $\overline{\text{KIN12}}$ /PS2BC PA3/ $\overline{\text{KIN11}}$ /PS2AD PA2/ $\overline{\text{KIN10}}$ /PS2AC PA1/ $\overline{\text{KIN9}}$ PA0/ $\overline{\text{KIN8}}$	On-chip input pull-up MOSs
Port B	General I/O port also functioning as wakeup event interrupt input and LPC input/output pins	PB7/ $\overline{\text{WUE7}}$ PB6/ $\overline{\text{WUE6}}$ PB5/ $\overline{\text{WUE5}}$ PB4/ $\overline{\text{WUE4}}$ PB3/ $\overline{\text{WUE3}}$ PB2/ $\overline{\text{WUE2}}$ PB1/ $\overline{\text{WUE1}}$ /LSCI PB0/ $\overline{\text{WUE0}}$ /LSMI	On-chip input pull-up MOSs
Port C	General I/O port	PC7 PC6 PC5 PC4 PC3 PC2 PC1 PC0	On-chip input pull-up MOSs
Port D	General I/O port	PD7 PD6 PD5 PD4 PD3 PD2 PD1 PD0	On-chip input pull-up MOSs

Port	Description	Mode 2 and Mode 3	I/O Status
Port E	General I/O port	PE7 PE6 PE5 PE4 PE3 PE2 PE1 PE0	On-chip input pull-up MOSs
Port F	General I/O port also functioning as TMR_X, TMR_Y, TMR_A, and TMR_B input/output pins	PF7/TMOY* PF6/ExTMOX* PF5/ExTMIY* PF4/ExTMIX* PF3/TMOB PF2/TMOA PF1/TMIB PF0/TMIA	On-chip input pull-up MOSs
Port G	General I/O port also functioning as IIC_1 and IIC_0 input/output pins	PG7/ExSCLB* PG6/ExSDAB* PG5/ExSCLA* PG4/ExSDAA* PG3 PG2 PG1 PG0	

Note: * The program development tool (emulator) does not support this function.

7.1 Port 1

Port 1 is an 8-bit I/O port. Port 1 pins also function as PWM output pins. Port 1 has the following registers.

- Port 1 data direction register (P1DDR)
- Port 1 data register (P1DR)
- Port 1 pull-up MOS control register (P1PCR)

7.1.1 Port 1 Data Direction Register (P1DDR)

P1DDR specifies input or output for the pins of port 1 on a bit-by-bit basis.

Bit	Bit Name	Initial Value	R/W	Description
7	P17DDR	0	W	The corresponding port 1 pins are output ports when the P1DDR bits are set to 1, and input ports when the P1DDR bits are cleared to 0.
6	P16DDR	0	W	
5	P15DDR	0	W	
4	P14DDR	0	W	
3	P13DDR	0	W	
2	P12DDR	0	W	
1	P11DDR	0	W	
0	P10DDR	0	W	

7.1.2 Port 1 Data Register (P1DR)

P1DR stores output data for the port 1 pins.

Bit	Bit Name	Initial Value	R/W	Description
7	P17DR	0	R/W	If a port 1 read is performed while the P1DDR bits are set to 1, the P1DR values are read. If a port 1 read is performed while the P1DDR bits are cleared to 0, the pin states are read.
6	P16DR	0	R/W	
5	P15DR	0	R/W	
4	P14DR	0	R/W	
3	P13DR	0	R/W	
2	P12DR	0	R/W	
1	P11DR	0	R/W	
0	P10DR	0	R/W	

7.1.3 Port 1 Pull-Up MOS Control Register (P1PCR)

P1PCR controls the on/off state of the port 1 on-chip input pull-up MOSs.

Bit	Bit Name	Initial Value	R/W	Description
7	P17PCR	0	R/W	When a P1PCR bit is set to 1 with the input port setting, the input pull-up MOS is turned on.
6	P16PCR	0	R/W	
5	P15PCR	0	R/W	
4	P14PCR	0	R/W	
3	P13PCR	0	R/W	
2	P12PCR	0	R/W	
1	P11PCR	0	R/W	
0	P10PCR	0	R/W	

7.1.4 Pin Functions

- P17/PW7 to P10/PW0

The pin function is switched as shown below according to the combination of the OEn bit in PWOERA of PWM and the P1nDDR bit.

P1nDDR	0	1	
OEn	—	0	1
Pin Function	P17 to P10 input pins	P17 to P10 output pins	PW7 to PW0 output pins

[Legend]

n = 7 to 0

7.1.5 Port 1 Input Pull-Up MOS

Port 1 has an on-chip input pull-up MOS function that can be controlled by software. This input pull-up MOS function can be specified as on or off on a bit-by-bit basis.

Table 7.2 summarizes the input pull-up MOS states.

Table 7.2 Input Pull-Up MOS States (Port 1)

Reset	Hardware Standby Mode	Software Standby Mode In Other Operations	
Off	Off	On/Off	On/Off

[Legend]

Off: Input pull-up MOS is always off.

On/Off: On when the pin is in the input state, P1DDR = 0, and P1PCR = 1: otherwise off.

7.2 Port 2

Port 2 is an 8-bit I/O port. Port 2 has an on-chip input pull-up MOS function that can be controlled by software. Port 2 has the following registers.

- Port 2 data direction register (P2DDR)
- Port 2 data register (P2DR)
- Port 2 pull-up MOS control register (P2PCR)

7.2.1 Port 2 Data Direction Register (P2DDR)

P2DDR specifies input or output for the pins of port 2 on a bit-by-bit basis.

Bit	Bit Name	Initial Value	R/W	Description
7	P27DDR	0	W	The corresponding port 2 pins are output ports when P2DDR bits are set to 1, and input ports when P2DDR bits are cleared to 0.
6	P26DDR	0	W	
5	P25DDR	0	W	
4	P24DDR	0	W	
3	P23DDR	0	W	
2	P22DDR	0	W	
1	P21DDR	0	W	
0	P20DDR	0	W	

7.2.2 Port 2 Data Register (P2DR)

P2DR stores output data for port 2.

Bit	Bit Name	Initial Value	R/W	Description
7	P27DR	0	R/W	If a port 2 read is performed while P2DDR bits are set to 1, the P2DR values are read directly, regardless of the actual pin states. If a port 2 read is performed while P2DDR bits are cleared to 0, the pin states are read.
6	P26DR	0	R/W	
5	P25DR	0	R/W	
4	P24DR	0	R/W	
3	P23DR	0	R/W	
2	P22DR	0	R/W	
1	P21DR	0	R/W	
0	P20DR	0	R/W	

7.2.3 Port 2 Pull-Up MOS Control Register (P2PCR)

P2PCR controls the port 2 on-chip input pull-up MOSs.

Bit	Bit Name	Initial Value	R/W	Description
7	P27PCR	0	R/W	The input pull-up MOS is turned on when a P2PCR bit is set to 1 in the input port state.
6	P26PCR	0	R/W	
5	P25PCR	0	R/W	
4	P24PCR	0	R/W	
3	P23PCR	0	R/W	
2	P22PCR	0	R/W	
1	P21PCR	0	R/W	
0	P20PCR	0	R/W	

7.2.4 Pin Functions

- P27, P26, P25, P24, P23, P22, P21, P20

The pin function is switched as shown below according to the state of the P2nDDR bit.

P2nDDR	0	1
Pin Function	P27 to P20 input pins	P27 to P20 output pins

[Legend]

n = 7 to 0

7.2.5 Port 2 Input Pull-Up MOS

Port 2 has an on-chip input pull-up MOS function that can be controlled by software. This input pull-up MOS function can be specified as on or off on a bit-by-bit basis.

Table 7.3 summarizes the input pull-up MOS states.

Table 7.3 Input Pull-Up MOS States (Port 2)

Reset	Hardware Standby Mode	Software Standby Mode	In Other Operations
Off	Off	On/Off	On/Off

[Legend]

Off: Input pull-up MOS is always off.

On/Off: On when the pin is in the input state, P2DDR = 0, and P2PCR = 1; otherwise off.

7.3 Port 3

Port 3 is an 8-bit I/O port. Port 3 pins also function as LPC input/output pins. Port 3 has the following registers.

- Port 3 data direction register (P3DDR)
- Port 3 data register (P3DR)
- Port 3 pull-up MOS control register (P3PCR)

7.3.1 Port 3 Data Direction Register (P3DDR)

P3DDR specifies input or output for the pins of port 3 on a bit-by-bit basis.

Bit	Bit Name	Initial Value	R/W	Description
7	P37DDR	0	W	The corresponding port 3 pins are output ports when P3DDR bits are set to 1, and input ports when P3DDR bits are cleared to 0.
6	P36DDR	0	W	
5	P35DDR	0	W	
4	P34DDR	0	W	
3	P33DDR	0	W	
2	P32DDR	0	W	
1	P31DDR	0	W	
0	P30DDR	0	W	

7.3.2 Port 3 Data Register (P3DR)

P3DR stores output data of port 3.

Bit	Bit Name	Initial Value	R/W	Description
7	P37DR	0	R/W	If a port 3 read is performed while P3DDR bits are set to 1, the P3DR values are read directly, regardless of the actual pin states. If a port 3 read is performed while P3DDR bits are cleared to 0, the pin states are read.
6	P36DR	0	R/W	
5	P35DR	0	R/W	
4	P34DR	0	R/W	
3	P33DR	0	R/W	
2	P32DR	0	R/W	
1	P31DR	0	R/W	
0	P30DR	0	R/W	

7.3.3 Port 3 Pull-Up MOS Control Register (P3PCR)

P3PCR controls the port 3 on-chip input pull-up MOSs on a bit-by-bit basis.

Bit	Bit Name	Initial Value	R/W	Description
7	P37PCR	0	R/W	The input pull-up MOS is turned on when a P3PCR bit is set to 1 in the input port state.
6	P36PCR	0	R/W	
5	P35PCR	0	R/W	The input pull-up MOS function cannot be used when the host interface is enabled.
4	P34PCR	0	R/W	
3	P33PCR	0	R/W	
2	P32PCR	0	R/W	
1	P31PCR	0	R/W	
0	P30PCR	0	R/W	

7.3.4 Pin Functions

- P37/SERIRQ, P36/LCLK, P35/ $\overline{\text{LRESET}}$, P34/ $\overline{\text{LFRAME}}$, P33/LAD3, P32/LAD2, P31/LAD1, P30/LAD0

The pin function is switched as shown below according to the combination of the LPC3E to LPC1E bits in HICR0 of the host interface (LPC) and the P3nDDR bit.

LPCmE	All 0		Not all 0
P3nDDR	0	1	0
Pin Function	P37 to P30 input pins	P37 to P30 output pins	LPC input/output pins

Note: The combination of bits not described in the above table must not be used.

m = 3 to 1: LPC input/output pins (SERIRQ, LCLK, $\overline{\text{LRESET}}$, $\overline{\text{LFRAME}}$, LAD3 to LAD0) when at least one of LPC3E to LPC1E is set to 1.

n = 7 to 0

7.3.5 Port 3 Input Pull-Up MOS

Port 3 has an on-chip input pull-up MOS function that can be controlled by software. This input pull-up MOS function can be specified as on or off on a bit-by-bit basis.

Table 7.4 summarizes the input pull-up MOS states.

Table 7.4 Input Pull-Up MOS States (Port 3)

Reset	Hardware Standby Mode	Software Standby Mode	In Other Operations
Off	Off	On/Off	On/Off

[Legend]

Off: Input pull-up MOS is always off.

On/Off: On when the pin is in the input state, P3DDR = 0, and P3PCR = 1; otherwise off.

7.4 Port 4

Port 4 is an 8-bit I/O port. Port 4 pins also function as TMR_0 and TMR_1 I/O pins, and the IIC_1 I/O pin. The output type of P42 is NMOS push-pull output. The output type of SDA1 is NMOS open-drain output. Port 4 has the following registers.

- Port 4 data direction register (P4DDR)
- Port 4 data register (P4DR)

7.4.1 Port 4 Data Direction Register (P4DDR)

P4DDR specifies input or output for the pins of port 4 on a bit-by-bit basis.

Bit	Bit Name	Initial Value	R/W	Description
7	P47DDR	0	W	When a bit in P4DDR is set to 1, the corresponding pin functions as an output port, and when cleared to 0, as an input port.
6	P46DDR	0	W	
5	P45DDR	0	W	
4	P44DDR	0	W	
3	P43DDR	0	W	
2	P42DDR	0	W	
1	P41DDR	0	W	
0	P40DDR	0	W	

7.4.2 Port 4 Data Register (P4DR)

P4DR stores output data for port 4.

Bit	Bit Name	Initial Value	R/W	Description
7	P47DR	0	R/W	If a port 4 read is performed while P4DDR bits are set to 1, the P4DR values are read directly, regardless of the actual pin states. If a port 4 read is performed while P4DDR bits are cleared to 0, the pin states are read.
6	P46DR	0	R/W	
5	P45DR	0	R/W	
4	P44DR	0	R/W	
3	P43DR	0	R/W	
2	P42DR	0	R/W	
1	P41DR	0	R/W	
0	P40DR	0	R/W	

7.4.3 Pin Functions

- P47

The pin function is switched as shown below according to the combination of the P47DDR bit.

P47DDR	0	1
Pin Function	P47 input pin	P47 output pin

- P46

The pin function is switched as shown below according to the combination of the P46DDR bit.

P46DDR	0	1
Pin Function	P46 input pin	P46 output pin

- P45/TMRI1

The pin function is switched as shown below according to the combination of the P45DDR bit.

P45DDR	0	1
Pin Function	P45 input pin	P45 output pin
	TMRI1 input pin	

Note: * When bits CCLR1 and CCLR0 in TCR1 of TMR_1 are set to 1, this pin is used as the TMRI1 input pin.

- P44/TMO1

The pin function is switched as shown below according to the combination of the OS3 to OS0 bits in TCSR of TMR_1 and the P44DDR bit.

OS3 to OS0	All 0		Not all 0
P44DDR	0	1	—
Pin Function	P44 input pin	P44 output pin	TMO1 output pin

- P43/TMCI1

The pin function is switched as shown below according to the state of the P43DDR bit.

P43DDR	0	1
Pin Function	P43 input pin	P43 output pin
	TMCI1 input pin*	

Note: * When the external clock is selected by the bits CKS2 to CKS0 in TCR1 of TMR_1, this pin is used as the TMCI1 input pin.

- P42/TMRI0/SDA1

The pin function is switched as shown below according to the combination of the ICE bit in ICCR of IIC_1, the IIC1AS and the IIC1BS bits in PGCTL*², and the P42DDR bit.

$$P42ICE = ICE \cdot (\overline{IIC1AS} + \overline{IIC1BS})^{*2}$$

P42ICE* ²	0	1	
P42DDR	0	1	—
Pin Function	P42 input pin	P42 output pin	SDA1 I/O pin
	TMRI0 input pin* ¹		

- Note:
1. SDA1 is an NMOS-only output, and has direct bus drive capability.
When bits CCLR1 and CCLR0 in TCR0 of TMR_0 are set to 1, this pin is used as the TMRI0 input pin. When the P42 output pin is set, the output type is NMOS push-pull output.
 2. The program development tool (emulator) does not support the function of PGCTL.
Thus P42ICE is treated as ICE.

- P41/TMO0

The pin function is switched as shown below according to the combination of the OS3 to OS0 bits in TCSR of TMR_0 and the P41DDR bit.

OS3 to OS0	All 0		Not all 0
P41DDR	0	1	—
Pin Function	P41 input pin	P41 output pin	TMO0 output pin

- P40/TMCI0

The pin function is switched as shown below according to the state of the P40DDR bit.

P40DDR	0	1
Pin Function	P40 input pin	P40 output pin
	TMCI0 input pin*	

Note: * When an external clock is selected with bits CKS2 to CKS0 in TCR0 of TMR_0, this pin is used as the TMCI0 input pin.

7.5 Port 5

Port 5 is a 3-bit I/O port. Port 5 pins also function as SCI_1 extended I/O pins, and the IIC_0 I/O pin. P52 and ExSCK1 are NMOS push-pull outputs, and SCL0 is an NMOS open-drain output. Port 5 has the following registers.

- Port 5 data direction register (P5DDR)
- Port 5 data register (P5DR)

7.5.1 Port 5 Data Direction Register (P5DDR)

P5DDR specifies input or output for the pins of port 5 on a bit-by-bit basis.

Bit	Bit Name	Initial Value	R/W	Description
7 to 3	—	All 1	—	Reserved The initial value should not be changed.
2	P52DDR	0	W	The corresponding port 5 pins are output ports when P5DDR bits are set to 1, and input ports when cleared to 0. As SCI_1 is initialized in software standby mode, the pin states are determined by the specifications of ICCR, PGCTL, P5DDR, and P5DR in IIC_0.
1	P51DDR	0	W	
0	P50DDR	0	W	

7.5.2 Port 5 Data Register (P5DR)

P5DR stores output data for port 5 pins.

Bit	Bit Name	Initial Value	R/W	Description
7 to 3	—	All 1	—	Reserved The initial value should not be changed.
2	P52DR	0	R/W	If a port 5 read is performed while P5DDR bits are set to 1, the P5DR values are read directly, regardless of the actual pin states. If a port 5 read is performed while P5DDR bits are cleared to 0, the pin states are read.
1	P51DR	0	R/W	
0	P50DR	0	R/W	

7.5.3 Pin Functions

- P52/ExSCK1*/SCL0

The pin function is switched as shown below according to the combination of the $\overline{C/\overline{A}}$ bit in SMR of SCI_1, the CKE0 and CKE1 bits in SCR, the SPS1 bit*¹ in SPSR, the ICE bit in ICCR of IIC_0, the IIC0AS and the IIC0BS bits in PGCTL*², and the P52DDR bit.

$$P52ICE = ICE \cdot (\overline{IIC0AS+IIC0BS})^{*2}$$

SPS1* ¹	0			1					
P52ICE* ²	0		1	0					1
CKE1	—	—	—	0			1	0	
C/ \overline{A}	—	—	—	0			1	—	0
CKE0	—	—	—	0		1	—	—	0
P52DDR	0	1	—	0	1	—	—	—	—
Pin Function	P52 input pin	P52 output pin	SCL0 I/O pin	P52 input pin	P52 output pin	ExSCK1* ¹ output pin	ExSCK1* ¹ output pin	ExSCK1* ¹ input pin	SCL0 I/O pin

- Note:
1. When this pin is used as the SCL0 I/O pin by setting 1 to the SPS1 bit of SPSR, the bits CKE1 and CKE0 in SCR of SCI_1 and the C/ \overline{A} bit in SMR must all be cleared to 0. SCL0 is an NMOS open-drain output. When set as the P52 output pin or ExSCK1 output pin, this pin is an NMOS push-pull output.
 2. The program development tool (emulator) does not support the function of PGCTL. Thus P52ICE is treated as ICE.

- P51/ExRxD1

The pin function is switched as shown below according to the combination of the RE bit in SCR of SCI_1, the SPS1 bit* in SPSR, and the P51DDR bit.

SPS1*	0		1		
RE	—		0		1
P51DDR	0	1	0	1	—
Pin Function	P51 input pin	P51 output pin	P51 input pin	P51 output pin	ExRxD1 input pin*

- Note: * The program development tool (emulator) does not support this function.

- P50/ExTxD1

The pin function is switched as shown below according to the combination of the TE bit in SCR of SCI_1, the SPS1 bit* in SPSR, and the P50DDR bit.

SPS1*	0		1		
TE	—		0		1
P50DDR	0	1	0	1	—
Pin Function	P50 input pin	P50 output pin	P50 input pin	P50 output pin	ExTxD1 output pin*

Note: * The program development tool (emulator) does not support this function.

7.6 Port 6

Port 6 is an 8-bit I/O port. Port 6 pins also function as the FRT I/O pins, TMR_X I/O pins, TMR_Y input pin, key-sense interrupt input pins, and interrupt input pins. Port 6 has the following registers.

- Port 6 data direction register (P6DDR)
- Port 6 data register (P6DR)
- Port 6 pull-up MOS control register (KMPCR)
- System control register 2 (SYSCR2)

7.6.1 Port 6 Data Direction Register (P6DDR)

P6DDR specifies input or output for the pins of port 6 on a bit-by-bit basis.

Bit	Bit Name	Initial Value	R/W	Description
7	P67DDR	0	W	The corresponding port 6 pins are output ports when P6DDR bits are set to 1, and input ports when cleared to 0.
6	P66DDR	0	W	
5	P65DDR	0	W	
4	P64DDR	0	W	
3	P63DDR	0	W	
2	P62DDR	0	W	
1	P61DDR	0	W	
0	P60DDR	0	W	

7.6.2 Port 6 Data Register (P6DR)

P6DR stores output data for port 6.

Bit	Bit Name	Initial Value	R/W	Description
7	P67DR	0	R/W	If a port 6 read is performed while P6DDR bits are set to 1, the P6DR values are read directly, regardless of the actual pin states. If a port 6 read is performed while P6DDR bits are cleared to 0, the pin states are read.
6	P66DR	0	R/W	
5	P65DR	0	R/W	
4	P64DR	0	R/W	
3	P63DR	0	R/W	
2	P62DR	0	R/W	
1	P61DR	0	R/W	
0	P60DR	0	R/W	

7.6.3 Port 6 Pull-Up MOS Control Register (KMPCR)

KMPCR controls the port 6 on-chip input pull-up MOSs on a bit-by-bit basis.

Bit	Bit Name	Initial Value	R/W	Description
7	KM7PCR	0	R/W	The input pull-up MOS is turned on when a KMPCR bit is set to 1 with the input port setting.
6	KM6PCR	0	R/W	
5	KM5PCR	0	R/W	
4	KM4PCR	0	R/W	
3	KM3PCR	0	R/W	
2	KM2PCR	0	R/W	
1	KM1PCR	0	R/W	
0	KM0PCR	0	R/W	

7.6.4 System Control Register 2 (SYSCR2)

SYSCR2 is not available in this LSI although originally designed to control the port 6 operations.

Bit	Bit Name	Initial Value	R/W	Description
7 to 0	—	All 0	R/W	Reserved The initial value should not be changed.

7.6.5 Pin Functions

- P67/TMOX/ $\overline{\text{KIN7}}$ / $\overline{\text{IRQ7}}$

The pin function is switched as shown below according to the combination of the OS3 to OS0 bits in TCSR of TMR_X, the IOSX bit*² in TCRXY, and the P67DDR bit.

IOSX* ²	0			1	
	All 0		Not all 0	—	
P67DDR	0	1	—	0	1
Pin Function	P67 input pin	P67 output pin	TMOX output pin	P67 input pin	P67 output pin
	$\overline{\text{IRQ7}}$ input pin, $\overline{\text{KIN7}}$ input pin* ¹				

- Notes: 1. This pin is used as the $\overline{\text{IRQ7}}$ input pin when bit $\overline{\text{IRQ7E}}$ is set to 1 in IER. It can always be used as the $\overline{\text{KIN7}}$ input pin.
2. The program development tool (emulator) does not support this function.

- P66/FTOB/ $\overline{\text{KIN6}}$ / $\overline{\text{IRQ6}}$

The pin function is switched as shown below according to the combination of the OEB bit in TOCR of the FRT and the P66DDR bit.

OEB	0		1
P66DDR	0	1	—
Pin Function	P66 input pin	P66 output pin	FTOB output pin
	IRQ6 input pin, $\overline{\text{KIN6}}$ input pin*		

Note: * This pin is used as the IRQ6 input pin when bit IRQ6E is set to 1 in IER while the KMIMR6 bit in KMIMR is 0. It can always be used as the $\overline{\text{KIN6}}$ input pin.

- P65/FTID/ $\overline{\text{KIN5}}$

P65DDR	0		1
Pin Function	P65 input pin		P65 output pin
	FTID input pin, $\overline{\text{KIN5}}$ input pin*		

Note: * This pin can always be used as the FTID or $\overline{\text{KIN5}}$ input pin.

- P64/FTIC/ $\overline{\text{KIN4}}$

The pin function is switched as shown below according to the state of the P64DDR bit.

P64DDR	0		1
Pin Function	P64 input pin		P64 output pin
	FTIC input pin, $\overline{\text{KIN4}}$ input pin*		

Note: * This pin can always be used as the FTIC or $\overline{\text{KIN4}}$ input pin.

- P63/FTIB/ $\overline{\text{KIN3}}$

P63DDR	0		1
Pin Function	P63 input pin		P63 output pin
	FTIB input pin, $\overline{\text{KIN3}}$ input pin*		

Note: * This pin can always be used as the FTIB or $\overline{\text{KIN3}}$ input pin.

- P62/FTIA/ $\overline{\text{KIN2}}$ /TMIY

P62DDR	0		1
Pin Function	P62 input pin		P62 output pin
	FTIA input pin, TMIY input pin, $\overline{\text{KIN2}}$ input pin*		

Note: * This pin can always be used as the FTIA or $\overline{\text{KIN2}}$ input pin. When the IOSY bit in TCRXY of TMR_Y is set to 0, this pin can be used as the TMIY input pin.

- P61/FTOA/ $\overline{\text{KIN1}}$

The pin function is switched as shown below according to the combination of the OEA bit in TOCR of the FRT, and the P61DDR bit.

OEA	0		1
P61DDR	0	1	—
Pin Function	P61 input pin	P61 output pin	FTOA input pin
	KIN1 input pin*		

Note: * This pin can always be used as the KIN1 input pin.

- P60/FTCI/ $\overline{\text{KIN0}}$ /TMIX

P60DDR	0	1
Pin Function	P60 input pin	P60 output pin
	FTCI input pin, TMIX input pin, $\overline{\text{KIN0}}$ input pin*	

Note: * This pin is used as the FTCl input pin when an external clock is selected with bits CKS1 and CKS0 in TCR of the FRT. It can always be used as the KIN0 input pin. When the IOSX bit in TCRXY of TMR_X is set to 0, this pin can be used as the TMIX input pin.

7.6.6 Port 6 Input Pull-Up MOS

Port 6 has an on-chip input pull-up MOS function that can be controlled by software. This input pull-up MOS function can be specified as on or off on a bit-by-bit basis.

When a pin is designated as an on-chip peripheral module output pin, the input pull-up MOS is always off.

Table 7.5 summarizes the input pull-up MOS states.

Table 7.5 Input Pull-Up MOS States (Port 6)

Reset	Hardware Standby Mode	Software Standby Mode	In Other Operations
Off	Off	On/Off	On/Off

[Legend]

Off: Input pull-up MOS is always off.

On/Off: On when the pin is in the input state, P6DDR = 0, and KMPCR = 1; otherwise off.

7.7 Port 7

Port 7 is an 8-bit input only port. Port 7 pins also function as the A/D converter analog input pins. Port 7 has the following register.

- Port 7 input data register (P7PIN)

7.7.1 Port 7 Input Data Register (P7PIN)

P7PIN reflects the pin states of port 7.

Bit	Bit Name	Initial Value	R/W	Description
7	P77PIN	Undefined*	R	When a P7PIN read is performed, the pin states are always read. P7PIN has the same address as PBDDR; if a write is performed, data will be written into PBDDR and the port B setting will be changed.
6	P76PIN	Undefined*	R	
5	P75PIN	Undefined*	R	
4	P74PIN	Undefined*	R	
3	P73PIN	Undefined*	R	
2	P72PIN	Undefined*	R	
1	P71PIN	Undefined*	R	
0	P70PIN	Undefined*	R	

Note: * Determined by the pin states of P77 to P70.

7.7.2 Pin Functions

- P77, P76

Pin Function	P77, P76 input pins
--------------	---------------------

- P75/AN5, P74/AN4, P73/AN3, P72/AN2, P71/AN1, P70/AN0

Pin Function	P75 to P70 input pins
	AN5 to AN0 input pins*

Note: * These pins can always be used as the AN5 to AN0 input pins respectively.

7.8 Port 8

Port 8 is an 8-bit I/O port. Port 8 pins also function as SCI_1 I/O pins, the IIC_1 I/O pins, LPC I/O pins, and interrupt input pins. The output type of P86 and SCK1 is NMOS push-pull output. The output type of SCL1 is NMOS open-drain output and direct bus driving is enabled. Port 8 has the following registers.

- Port 8 data direction register (P8DDR)
- Port 8 data register (P8DR)

7.8.1 Port 8 Data Direction Register (P8DDR)

P8DDR specifies input or output for the pins of port 8 on a bit-by-bit basis.

Bit	Bit Name	Initial Value	R/W	Description
7	—	1	—	Reserved The initial value should not be changed.
6	P86DDR	0	W	P8DDR has the same address as PBPIN, and if read, the port B state will be returned.
5	P85DDR	0	W	
4	P84DDR	0	W	The corresponding port 8 pins are output ports when P8DDR bits are set to 1, and input ports when cleared to 0.
3	P83DDR	0	W	
2	P82DDR	0	W	
1	P81DDR	0	W	
0	P80DDR	0	W	

7.8.2 Port 8 Data Register (P8DR)

P8DR stores output data for the port 8 pins (P86 to P80).

Bit	Bit Name	Initial Value	R/W	Description
7	—	1	—	Reserved The initial value should not be changed.
6	P86DR	0	R/W	If a port 8 read is performed while P8DDR bits are set to 1, the P8DR values are read directly, regardless of the actual pin states. If a port 8 read is performed while P8DDR bits are cleared to 0, the pin states are read.
5	P85DR	0	R/W	
4	P84DR	0	R/W	
3	P83DR	0	R/W	
2	P82DR	0	R/W	
1	P81DR	0	R/W	
0	P80DR	0	R/W	

7.8.3 Pin Functions

- P86/ $\overline{\text{IRQ5}}$ /SCK1/SCL1

The pin function is switched as shown below according to the combination of the $\overline{\text{C/A}}$ bit in SMR of SCI_1, the CKE0 and CKE1 bits in SCR, the SPS1 bit*² in SPSR, the ICE bit in ICCR of IIC_1, the IIC1AS and the IIC1BS bits in PGCTL*³, and the 86DDR bit.

$$\text{P86ICE} = \text{ICE} \bullet (\overline{\text{IIC1AS} + \text{IIC1BS}})^{*3}$$

SPS1* ²	0					1			
P86ICE* ³	0				1	0			1
CKE1	0			1	0	—	—	—	
C/A	0			1	—	0	—	—	
CKE0	0		1	—	—	0	—	—	
P86DDR	0	1	—	—	—	—	0	1	
Pin Function	P86 input pin	P86 output pin	SCK1 output pin	SCK1 output pin	SCK1 input pin	SCL1 I/O pin	P86 input pin	P86 output pin	SCL1 I/O pin
	$\overline{\text{IRQ5}}$ input pin* ¹								

- Notes:
1. When the IRQ5E bit in IER is set to 1, this pin is used as the $\overline{\text{IRQ5}}$ input pin. When this pin is used as the SCL1 I/O pin, bits CKE1 and CKE0 in SCR of SCI_1 and bit C/A in SMR of SCI_1 must all be cleared to 0. When the P86 output pin and SCK1 output pin are set, the output type is NMOS push-pull output. SCL1 is an NMOS-only output, and has direct bus drive capability.
 2. The program development tool (emulator) does not support this function.
 3. The program development tool (emulator) does not support the function of PGCTL. Thus P86ICE is treated as ICE.

- P85/ $\overline{\text{IRQ4}}$ /RxD1

The pin function is switched as shown below according to the combination of the RE bit in SCR of SCI_1, the SPS1 bit*² in SPSR, and the P85DDR bit.

SPS1* ²	0			1	
RE	0		1	—	
P85DDR	0	1	—	0	1
Pin Function	P85 input pin	P85 output pin	RxD1 input pin	P85 input pin	P85 output pin
	$\overline{\text{IRQ4}}$ input pin* ¹				

- Notes:
1. When the IRQ4E bit in IER is set to 1, this pin is used as the $\overline{\text{IRQ4}}$ input pin.
 2. The program development tool (emulator) does not support this function.

- P84/ $\overline{\text{IRQ3}}$ /TxD1

The pin function is switched as shown below according to the combination of the TE bit in SCR of SCI_1, the SPS1 bit*² in SPSR, and the P84DDR bit.

SPS1* ²	0			1	
TE	0		1	—	
P84DDR	0	1	—	0	1
Pin Function	P84 input pin	P84 output pin	TxD1 output pin	P84 input pin	P84 output pin
	$\overline{\text{IRQ3}}$ input pin* ¹				

- Notes: 1. When the IRQ3E bit in IER is set to 1, this pin is used as the $\overline{\text{IRQ3}}$ input pin.
 2. The program development tool (emulator) does not support this function.

- P83/ $\overline{\text{LPCPD}}$

The pin function is switched as shown below according to the state of the P83DDR bit.

P83DDR	0	1
Pin Function	P83 input pin	P83 output pin
	$\overline{\text{LPCPD}}$ input pin*	

Note: * When at least one of bits LPC3E to LPC1E is set to 1 in HICR0, this pin is used as the $\overline{\text{LPCPD}}$ input pin.

- P82/ $\overline{\text{CLKRUN}}$

The pin function is switched as shown below according to the combination of the LPC3E to LPC1E bits in HICR0, and the P82DDR bit.

LPC3E to LPC1E	All 0		Not all 0
P82DDR	0	1	0*
Pin Function	P82 input pin	P82 output pin	$\overline{\text{CLKRUN}}$ I/O pin

Note: * When at least one of bits LPC3E to LPC1E is set to 1 in HICR0, the P82DDR should be cleared to 0.

- P81/GA20

The pin function is switched as shown below according to the combination of the FGA20E bit in HICR0 and the P81DDR bit.

FGA20E	0		1
P81DDR	0	1	0*
Pin Function	P81 input pin	P81 output pin	GA20 output pin
	GA20 input pin		

Note: * When bit FGA20E is set to 1 in HICR0, the P81DDR bit should be cleared to 0.

- P80/ $\overline{\text{PME}}$

The pin function is switched as shown below according to the combination of the PMEE bit in HICR0 and the P80DDR bit.

PMEE	0		1
P80DDR	0	1	0*
Pin Function	P80 input pin	P80 output pin	$\overline{\text{PME}}$ output pin
	$\overline{\text{PME}}$ input pin		

Note: * When bit PMEE is set to 1 in HICR0, the P80DDR bit should be cleared to 0.

7.9 Port 9

Port 9 is an 8-bit I/O port. Port 9 pins also function as the interrupt input pins, IIC_0 I/O pin, subclock input pin, and system clock (ϕ) output pin. P97 is an NMOS push-pull output. SDA0 is an NMOS open-drain output, and has direct bus drive capability. Port 9 has the following registers.

- Port 9 data direction register (P9DDR)
- Port 9 data register (P9DR)

7.9.1 Port 9 Data Direction Register (P9DDR)

P9DDR specifies input or output for the pins of port 9 on a bit-by-bit basis.

Bit	Bit Name	Initial Value	R/W	Description
7	P97DDR	0	W	When the corresponding P9DDR bits are set to 1, pin P96 functions as the ϕ output pin and pins P97 and P95 to P90 become output ports. When P9DDR bits are cleared to 0, the corresponding pins become input ports.
6	P96DDR	0	W	
5	P95DDR	0	W	
4	P94DDR	0	W	
3	P93DDR	0	W	
2	P92DDR	0	W	
1	P91DDR	0	W	
0	P90DDR	0	W	

7.9.2 Port 9 Data Register (P9DR)

P9DR stores output data for the port 9 pins.

Bit	Bit Name	Initial Value	R/W	Description	
7	P97DR	0	R/W	With the exception of P96, if a port 9 read is performed while P9DDR bits are set to 1, the P9DR values are read directly, regardless of the actual pin states. If a port 9 read is performed while P9DDR bits are cleared to 0, the pin states are read.	
6	P96DR	Undefined*	R		
5	P95DR	0	R/W		
4	P94DR	0	R/W		
3	P93DR	0	R/W		For P96, the pin state is always read.
2	P92DR	0	R/W		
1	P91DR	0	R/W		
0	P90DR	0	R/W		

Note: * The initial value of bit 6 is determined according to the P96 pin state.

7.9.3 Pin Functions

- P97/SDA0

The pin function is switched as shown below according to the combination of the ICE bit in ICCR of IIC_0, the IIC0AS and the IIC0BS bits in PGCTL*, and the P97DDR bit.

$$P97ICE = ICE \cdot \overline{(IIC0AS + IIC0BS)}^*$$

P97ICE*	0		1
P97DDR	0	1	—
Pin Function	P97 input pin	P97 output pin	SDA0 I/O pin

Note: When this pin is set as the P97 output pin, it is an NMOS push-pull output. SDA0 is an NMOS open-drain output, and has direct bus drive capability.

* The program development tool (emulator) does not support the function of PGCTL. Thus P97ICE is treated as ICE.

- P96/ ϕ /EXCL

The pin function is switched as shown below according to the combination of the EXCLE bit in LPWRCR and the P96DDR bit.

P96DDR	0		1
EXCLE	0	1	0
Pin Function	P96 input pin	EXCL input pin	ϕ output pin

Note: * When this pin is used as the EXCL input pin, P96DDR should be cleared to 0.

- P95

The pin function is switched as shown below according to the state of the P95DDR bit.

P95DDR	0	1
Pin Function	P95 input pin	P95 output pin

- P94

The pin function is switched as shown below according to the state of the P94DDR bit.

P94DDR	0	1
Pin Function	P94 input pin	P94 output pin

- P93

The pin function is switched as shown below according to the state of the P93DDR bit.

P93DDR	0	1
Pin Function	P93 input pin	P93 output pin

- P92/ $\overline{\text{IRQ0}}$

The pin function is switched as shown below according to the state of the P92DDR bit.

P92DDR	0	1
Pin Function	P92 input pin	P92 output pin
	$\overline{\text{IRQ0}}$ input pin*	

Note: * When bit IRQ0E in IER is set to 1, this pin is used as the $\overline{\text{IRQ0}}$ input pin.

- P91/ $\overline{\text{IRQ1}}$

The pin function is switched as shown below according to the state of the P91DDR bit.

P91DDR	0	1
Pin Function	P91 input pin	P91 output pin
	$\overline{\text{IRQ1}}$ input pin*	

Note: * When bit IRQ1E in IER is set to 1, this pin is used as the $\overline{\text{IRQ1}}$ input pin.

- P90/ $\overline{\text{IRQ2}}$ / $\overline{\text{ADTRG}}$

The pin function is switched as shown below according to the state of the P90DDR bit.

P90DDR	0	1
Pin Function	P90 input pin	P90 output pin
	$\overline{\text{IRQ2}}$ input pin, $\overline{\text{ADTRG}}$ input pin*	

Note: * When the IRQ2E bit in IER is set to 1, this pin is used as the $\overline{\text{IRQ2}}$ input pin. When both bits TRGS1 and TRGS0 in ADCR of the A/D converter are set to 1, this pin is used as the $\overline{\text{ADTRG}}$ input pin.

7.10 Port A

Port A is an 8-bit I/O port. Port A pins also function as keyboard buffer controller I/O pins, and key-sense interrupt input pins. Port A input/output operates by VccB power independent from the Vcc power. Up to 5 V can be applied to port A pins if VccB power is 5 V. Port A has the following registers. PADDR and PAPIN have the same address.

- Port A data direction register (PADDR)
- Port A output data register (PAODR)
- Port A input data register (PAPIN)

7.10.1 Port A Data Direction Register (PADDR)

PADDR specifies input or output for the pins of port A on a bit-by-bit basis.

Bit	Bit Name	Initial Value	R/W	Description
7	PA7DDR	0	W	The corresponding port A pins are output ports when PADDR bits are set to 1, and input ports when cleared to 0.
6	PA6DDR	0	W	
5	PA5DDR	0	W	PA7 to PA2 pins are used as the keyboard buffer controller I/O pins by setting the KBIOE bit to 1, while the I/O direction according to PA7DDR to PA2DDR is ignored.
4	PA4DDR	0	W	
3	PA3DDR	0	W	
2	PA2DDR	0	W	PADDR has the same address as PAPIN, if read, port A state is returned.
1	PA1DDR	0	W	
0	PA0DDR	0	W	

7.10.2 Port A Output Data Register (PAODR)

PAODR stores output data for port A.

Bit	Bit Name	Initial Value	R/W	Description
7	PA7ODR	0	R/W	PAODR can always be read or written to, regardless of the contents of PADDR.
6	PA6ODR	0	R/W	
5	PA5ODR	0	R/W	
4	PA4ODR	0	R/W	
3	PA3ODR	0	R/W	
2	PA2ODR	0	R/W	
1	PA1ODR	0	R/W	
0	PA0ODR	0	R/W	

7.10.3 Port A Input Data Register (PAPIN)

PAPIN indicates the port A state.

Bit	Bit Name	Initial Value	R/W	Description
7	PA7PIN	Undefined*	R	Reading PAPIN always returns the pin states. PAPIN has the same address as PADDR. If a write is performed, the port A settings will change.
6	PA6PIN	Undefined*	R	
5	PA5PIN	Undefined*	R	
4	PA4PIN	Undefined*	R	
3	PA3PIN	Undefined*	R	
2	PA2PIN	Undefined*	R	
1	PA1PIN	Undefined*	R	
0	PA0PIN	Undefined*	R	

Note: * The initial value is determined according to the PA7 to PA0 pin states.

7.10.4 Pin Functions

- PA7/ $\overline{\text{KIN15}}$ /PS2CD

The pin function is switched as shown below according to the combination of the KBIOE bit in KBCRH_2 of the keyboard buffer controller, and the PA7DDR bit.

KBIOE	0		1
PA7DDR	0	1	—
Pin Function	PA7 input pin	PA7 output pin	PS2CD output pin
	KIN15 input pin, PS2CD input pin*		

Note: * When the KBIOE bit is set to 1 or the IICS bit in STCR is set to 1, this pin is an NMOS open-drain output, and has direct bus drive capability. This pin can always be used as the PS2CD or KIN15 input pin.

- PA6/ $\overline{\text{KIN14}}$ /PS2CC

The pin function is switched as shown below according to the combination of the KBIOE bit in KBCRH_2 of the keyboard buffer controller, and the PA6DDR bit.

KBIOE	0		1
PA6DDR	0	1	—
Pin Function	PA6 input pin	PA6 output pin	PS2CC output pin
	KIN14 input pin, PS2CC input pin*		

Note: * When the KBIOE bit is set to 1 or the IICS bit in STCR is set to 1, this pin is an NMOS open-drain output, and has direct bus drive capability. This pin can always be used as the PS2CC or $\overline{\text{KIN14}}$ input pin.

- PA5/ $\overline{\text{KIN13}}$ /PS2BD

The pin function is switched as shown below according to the combination of the KBIOE bit in KBCRH_1 of the keyboard buffer controller, and the PA5DDR bit.

KBIOE	0		1
PA5DDR	0	1	—
Pin Function	PA5 input pin	PA5 output pin	PS2BD output pin
	KIN13 input pin, PS2BD input pin*		

Note: * When the KBIOE bit is set to 1 or the IICS bit in STCR is set to 1, this pin is an NMOS open-drain output, and has direct bus drive capability. This pin can always be used as the PS2BD or KIN13 input pin.

- PA4/ $\overline{\text{KIN12}}$ /PS2BC

The pin function is switched as shown below according to the combination of the KBIOE bit in KBCRH_1 of the keyboard buffer controller, and the PA4DDR bit.

KBIOE	0		1
PA4DDR	0	1	—
Pin Function	PA4 input pin	PA4 output pin	PS2BC output pin
	KIN12 input pin, PS2BC input pin*		

Note: * When the KBIOE bit is set to 1 or the IICS bit in STCR is set to 1, this pin is an NMOS open-drain output, and has direct bus drive capability. This pin can always be used as the PS2BC or KIN12 input pin.

- PA3/ $\overline{\text{KIN11}}$ /PS2AD

The pin function is switched as shown below according to the combination of the KBIOE bit in KBCRH_0 of the keyboard buffer controller, and the PA3DDR bit.

KBIOE	0		1
PA3DDR	0	1	—
Pin Function	PA3 input pin	PA3 output pin	PS2AD output pin
	KIN11 input pin, PS2AD input pin*		

Note: * When the KBIOE bit is set to 1, this pin is an NMOS open-drain output, and has direct bus drive capability. This pin can always be used as the PS2AD or KIN11 input pin.

- PA2/ $\overline{\text{KIN10}}$ /PS2AC

The pin function is switched as shown below according to the combination of the KBIOE bit in KBCRH_0 of the keyboard buffer controller, and the PA2DDR bit.

KBIOE	0		1
PA2DDR	0	1	—
Pin Function	PA2 input pin	PA2 output pin	PS2AC output pin
	KIN10 input pin, PS2AC input pin*		

Note: * When the KBIOE bit is set to 1, this pin is an NMOS open-drain output, and has direct bus drive capability. This pin can always be used as the PS2AC or KIN10 input pin.

- PA1/ $\overline{\text{KIN9}}$, PA0/ $\overline{\text{KIN8}}$

The pin function is switched as shown below according to the state of the PAnDDR bit.

PAnDDR	0	1
Pin Function	PAn input pin	PAn output pin
	KINm input pin*	

Note: * This pin can always be used as the KINm input pin. (n = 1 or 0, m = 9 or 8)

7.10.5 Port A Input Pull-Up MOS

Port A has an on-chip input pull-up MOS function that can be controlled by software. This input pull-up MOS function can be specified as on or off on a bit-by-bit basis.

The input pull-up MOS for pins PA7 to PA4 is always off when IICS is set to 1. When the keyboard buffer control pin function is selected for pins PA7 to PA2, the input pull-up MOS is always off.

Table 7.6 summarizes the input pull-up MOS states.

Table 7.6 Input Pull-Up MOS States (Port A)

Reset	Hardware Standby Mode	Software Standby Mode	In Other Operations
Off	Off	On/Off	On/Off

[Legend]

Off: Input pull-up MOS is always off.

On/Off: On when the pin is in the input state, PADDR = 0, and PAODR = 1; otherwise off.

7.11 Port B

Port B is an 8-bit I/O port. Port B pins also have LPC input/output pins, and wakeup event interrupt input pins function. Port B has the following registers.

- Port B data direction register (PBDDR)
- Port B output data register (PBODR)
- Port B input data register (PBPIN)

7.11.1 Port B Data Direction Register (PBDDR)

PBDDR specifies input or output for the pins of port B on a bit-by-bit basis.

Bit	Bit Name	Initial Value	R/W	Description
7	PB7DDR	0	W	PBDDR has the same address as P7PIN, and if read, the port 7 pin states will be returned.
6	PB6DDR	0	W	
5	PB5DDR	0	W	A port B pin becomes an output port if the corresponding PBDDR bit is set to 1, and an input port if the bit is cleared to 0.
4	PB4DDR	0	W	
3	PB3DDR	0	W	
2	PB2DDR	0	W	
1	PB1DDR	0	W	
0	PB0DDR	0	W	

7.11.2 Port B Output Data Register (PBODR)

PBODR stores output data for port B.

Bit	Bit Name	Initial Value	R/W	Description
7	PB7ODR	0	R/W	PBODR can always be read or written to, regardless of the contents of PBDDR.
6	PB6ODR	0	R/W	
5	PB5ODR	0	R/W	
4	PB4ODR	0	R/W	
3	PB3ODR	0	R/W	
2	PB2ODR	0	R/W	
1	PB1ODR	0	R/W	
0	PB0ODR	0	R/W	

7.11.3 Port B Input Data Register (PBPIN)

PBPIN indicates the port B state.

Bit	Bit Name	Initial Value	R/W	Description
7	PB7PIN	Undefined*	R	Reading PBPIN always returns the pin states. PBPIN has the same address as P8DDR. If a write is performed, data will be written to P8DDR and the port 8 settings will change.
6	PB6PIN	Undefined*	R	
5	PB5PIN	Undefined*	R	
4	PB4PIN	Undefined*	R	
3	PB3PIN	Undefined*	R	
2	PB2PIN	Undefined*	R	
1	PB1PIN	Undefined*	R	
0	PB0PIN	Undefined*	R	

Note: * The initial value is determined according to the PB7 to PB0 pin states.

7.11.4 Pin Functions

- $\overline{PB7}/\overline{WUE7}$, $\overline{PB6}/\overline{WUE6}$, $\overline{PB5}/\overline{WUE5}$, $\overline{PB4}/\overline{WUE4}$, $\overline{PB3}/\overline{WUE3}$, $\overline{PB2}/\overline{WUE2}$

The pin function is switched as shown below according to the state of the $PBnDDR$ bit.

$PBnDDR$	0	1
Pin Function	PBn input pin	PBn output pin
	$\overline{WUE}n$ input pin*	

Note: * This pin can always be used as the $\overline{WUE}n$ input pin. (n = 7 to 2)

- $\overline{PB1}/\overline{WUE1}/LSCI$

The pin function is switched as shown below according to the combination of the LSCIE bit in HICR0 of the host interface (LPC) and the $PB1DDR$ bit.

LSCIE	0		1
$PB1DDR$	0	1	0^{*1}
Pin Function	$PB1$ input pin	$PB1$ output pin	LSCI output pin
	$\overline{WUE1}$ input pin* ² , LSCI input pin* ²		

Notes: 1. When the LSCIE bit in HICR0 is set to 1, the $PB1DDR$ bit should be cleared to 0.

2. This pin can always be used as the $\overline{WUE1}$ or LSCI input pin.

- $\overline{\text{PB0}}/\overline{\text{WUE0}}/\overline{\text{LSMI}}$

The pin function is switched as shown below according to the combination of the LSMIE bit in HICR0 of the host interface (LPC) and the PB0DDR bit.

LSMIE	0		1
PB0DDR	0	1	0^{*1}
Pin Function	PB0 input pin	PB0 output pin	$\overline{\text{LSMI}}$ output pin
	$\overline{\text{WUE0}}$ input pin ^{*2} , $\overline{\text{LSMI}}$ input pin ^{*2}		

Notes: 1. When the LSMIE bit in HICR0 is set to 1, the PB0DDR bit should be cleared to 0.

2. This pin can always be used as the $\overline{\text{WUE0}}$ or $\overline{\text{LSMI}}$ input pin.

7.11.5 Port B Input Pull-Up MOS

Port B has an on-chip input pull-up MOS function that can be controlled by software. This input pull-up MOS function can be specified as on or off on a bit-by-bit basis.

When a pin is designated as an on-chip peripheral module output pin, the input pull-up MOS is always off.

Table 7.7 summarizes the input pull-up MOS states.

Table 7.7 Input Pull-Up MOS States (Port B)

Reset	Hardware Standby Mode	Software Standby Mode	In Other Operations
Off	Off	On/Off	On/Off

[Legend]

Off: Input pull-up MOS is always off.

On/Off: On when the pin is in the input state, PBDDR = 0, and PBODR = 1; otherwise off.

7.12 Ports C, D

Port C and port D are two sets of 8-bit I/O ports. Port C and port D have the following registers.

- Port C data direction register (PCDDR)
- Port C output data register (PCODR)
- Port C input data register (PCPIN)
- Port C Nch-OD control register (PCNOCR)
- Port D data direction register (PDDDR)
- Port D output data register (PDODR)
- Port D input data register (PDPIN)
- Port D Nch-OD control register (PDNOCR)

7.12.1 Port C and Port D Data Direction Registers (PCDDR, PDDDR)

PCDDR and PDDDR select input or output for the pins of port C and port D on a bit-by-bit basis.

Bit	Bit Name	Initial Value	R/W	Description
7	PC7DDR	0	W	0: Port C pin is an input pin
6	PC6DDR	0	W	1: Port C pin is an output pin
5	PC5DDR	0	W	PCDDR has the same address as PCPIN, and if read, the port C pin states will be returned.
4	PC4DDR	0	W	
3	PC3DDR	0	W	
2	PC2DDR	0	W	
1	PC1DDR	0	W	
0	PC0DDR	0	W	

Bit	Bit Name	Initial Value	R/W	Description
7	PD7DDR	0	W	0: Port D pin is an input pin
6	PD6DDR	0	W	1: Port D pin is an output pin
5	PD5DDR	0	W	PDDDR has the same address as PDPIN, and if read, the port D pin states will be returned.
4	PD4DDR	0	W	
3	PD3DDR	0	W	
2	PD2DDR	0	W	
1	PD1DDR	0	W	
0	PD0DDR	0	W	

7.12.2 Port C and Port D Output Data Registers (PCODR, PDODR)

PCODR and PDODR store output data for the pins on ports C and D.

Bit	Bit Name	Initial Value	R/W	Description
7	PC7ODR	0	R/W	PCODR can always be read or written to, regardless of the contents of PCDDR.
6	PC6ODR	0	R/W	
5	PC5ODR	0	R/W	
4	PC4ODR	0	R/W	
3	PC3ODR	0	R/W	
2	PC2ODR	0	R/W	
1	PC1ODR	0	R/W	
0	PC0ODR	0	R/W	

Bit	Bit Name	Initial Value	R/W	Description
7	PD7ODR	0	R/W	PDODR can always be read or written to, regardless of the contents of PDDDR.
6	PD6ODR	0	R/W	
5	PD5ODR	0	R/W	
4	PD4ODR	0	R/W	
3	PD3ODR	0	R/W	
2	PD2ODR	0	R/W	
1	PD1ODR	0	R/W	
0	PD0ODR	0	R/W	

7.12.3 Port C and Port D Input Data Registers (PCPIN, PDPIN)

Reading PCPIN and PDPIN always returns the pin states.

Bit	Bit Name	Initial Value	R/W	Description
7	PC7PIN	Undefined*	R	PCPIN indicates the port C state. PCPIN has the same address as PCDDR. If a write is performed, the port C settings will change.
6	PC6PIN	Undefined*	R	
5	PC5PIN	Undefined*	R	
4	PC4PIN	Undefined*	R	
3	PC3PIN	Undefined*	R	
2	PC2PIN	Undefined*	R	
1	PC1PIN	Undefined*	R	
0	PC0PIN	Undefined*	R	

Note: * The initial value is determined according to the PC7 to PC0 pin states.

Bit	Bit Name	Initial Value	R/W	Description
7	PD7PIN	Undefined*	R	PDPIN indicates the port D state. PDPIN has the same address as PDDDR. If a write is performed, the port D settings will change.
6	PD6PIN	Undefined*	R	
5	PD5PIN	Undefined*	R	
4	PD4PIN	Undefined*	R	
3	PD3PIN	Undefined*	R	
2	PD2PIN	Undefined*	R	
1	PD1PIN	Undefined*	R	
0	PD0PIN	Undefined*	R	

Note: * The initial value is determined according to the PD7 to PD0 pin states.

7.12.4 Port C and Port D Nch-OD Control Register (PCNOCR, PDNOCR)

PCNOCR and PDNOCR specify the output driver type for pins on ports C and D which are configured as outputs on a bit-by-bit basis.

Bit	Bit Name	Initial Value	R/W	Description
7	PC7NOCR	0	R/W	0: CMOS (p-channel driver enabled)
6	PC6NOCR	0	R/W	1: N-channel open drain (p-channel driver disabled)
5	PC5NOCR	0	R/W	
4	PC4NOCR	0	R/W	
3	PC3NOCR	0	R/W	
2	PC2NOCR	0	R/W	
1	PC1NOCR	0	R/W	
0	PC0NOCR	0	R/W	

Bit	Bit Name	Initial Value	R/W	Description
7	PD7NOCR	0	R/W	0: CMOS (p-channel driver enabled)
6	PD6NOCR	0	R/W	1: N-channel open drain (p-channel driver disabled)
5	PD5NOCR	0	R/W	
4	PD4NOCR	0	R/W	
3	PD3NOCR	0	R/W	
2	PD2NOCR	0	R/W	
1	PD1NOCR	0	R/W	
0	PD0NOCR	0	R/W	

7.12.5 Pin Functions

DDR	0		1			
NOCR	—		0		1	
ODR	0	1	0	1	0	1
N-ch. driver	OFF		ON	OFF	ON	OFF
P-ch. driver	OFF		OFF	ON	OFF	
Input pull-up MOS	OFF	ON	OFF			
Pin function	Input pin		Output pin			

7.12.6 Input Pull-Up MOS in Ports C and D

Port C and port D have an on-chip input pull-up MOS function that can be controlled by software. This input pull-up MOS function can be switched on or off on a bit-by-bit basis.

Table 7.8 is a summary of the input pull-up MOS states.

Table 7.8 Input Pull-Up MOS States (Port C and port D)

Reset	Hardware Standby Mode	Software Standby Mode	Other Operations
Off	Off	On/Off	On/Off

[Legend]

Off: Input pull-up MOS is always off.

On/Off: On when PCDDR = 0 and PCODR = 1 (PDDDR = 0 and PDODR = 1); otherwise off.

7.13 Ports E, F

Ports E and F are two sets of 8-bit I/O ports. Port F also functions as I/O pins for TMR_X*, TMR_Y*, TMR_A, and TMR_B. Ports E and F have the following registers.

- Port E data direction register (PEDDR)
- Port E output data register (PEODR)
- Port E input data register (PEPIN)
- Port E Nch-OD control register (PENOCR)
- Port F data direction register (PFDDR)
- Port F output data register (PFODR)
- Port F input data register (PFPIN)
- Port F Nch-OD control register (PFNOCR)

Note: * The program development tool (emulator) does not support this function.

7.13.1 Port E and Port F Data Direction Registers (PEDDR, PFDDR)

PEDDR and PFDDR select input or output for the pins of port E and port F on a bit-by-bit basis.

Bit	Bit Name	Initial Value	R/W	Description
7	PE7DDR	0	W	0: Port E pin is an input pin
6	PE6DDR	0	W	1: Port E pin is an output pin
5	PE5DDR	0	W	PEDDR has the same address as PEPIN, and if read, the port E pin states will be returned.
4	PE4DDR	0	W	
3	PE3DDR	0	W	
2	PE2DDR	0	W	
1	PE1DDR	0	W	
0	PE0DDR	0	W	

Bit	Bit Name	Initial Value	R/W	Description
7	PF7DDR	0	W	0: Port F pin is an input pin
6	PF6DDR	0	W	1: Port F pin is an output pin
5	PF5DDR	0	W	PFDDR has the same address as PFPIN, and if read, the port F pin states will be returned.
4	PF4DDR	0	W	
3	PF3DDR	0	W	
2	PF2DDR	0	W	
1	PF1DDR	0	W	
0	PF0DDR	0	W	

7.13.2 Port E and Port F Output Data Registers (PEODR, PFODR)

PEODR and PFODR store output data for the pins on ports E and F.

Bit	Bit Name	Initial Value	R/W	Description
7	PE7ODR	0	R/W	PEODR can always be read or written to, regardless of the contents of PEDDR.
6	PE6ODR	0	R/W	
5	PE5ODR	0	R/W	
4	PE4ODR	0	R/W	
3	PE3ODR	0	R/W	
2	PE2ODR	0	R/W	
1	PE1ODR	0	R/W	
0	PE0ODR	0	R/W	

Bit	Bit Name	Initial Value	R/W	Description
7	PF7ODR	0	R/W	PFODR can always be read or written to, regardless of the contents of PFDDR.
6	PF6ODR	0	R/W	
5	PF5ODR	0	R/W	
4	PF4ODR	0	R/W	
3	PF3ODR	0	R/W	
2	PF2ODR	0	R/W	
1	PF1ODR	0	R/W	
0	PF0ODR	0	R/W	

7.13.3 Port E and Port F Input Data Registers (PEPIN, PFPIN)

Reading PEPIN and PFPIN always returns the pin states.

Bit	Bit Name	Initial Value	R/W	Description
7	PE7PIN	Undefined*	R	PEPIN indicates the port E state. PEPIN has the same address as PEDDR. If a write is performed, the port E settings will change.
6	PE6PIN	Undefined*	R	
5	PE5PIN	Undefined*	R	
4	PE4PIN	Undefined*	R	
3	PE3PIN	Undefined*	R	
2	PE2PIN	Undefined*	R	
1	PE1PIN	Undefined*	R	
0	PE0PIN	Undefined*	R	

Note: * The initial value is determined according to the PE7 to PE0 pin states.

Bit	Bit Name	Initial Value	R/W	Description
7	PF7PIN	Undefined*	R	PFPIN indicates the port F state. PFPIN has the same address as PFDDR. If a write is performed, the port F settings will change.
6	PF6PIN	Undefined*	R	
5	PF5PIN	Undefined*	R	
4	PF4PIN	Undefined*	R	
3	PF3PIN	Undefined*	R	
2	PF2PIN	Undefined*	R	
1	PF1PIN	Undefined*	R	
0	PF0PIN	Undefined*	R	

Note: * The initial value is determined according to the PF7 to PF0 pin states.

7.13.4 Pin Functions

- PF7/TMOY

The pin function is switched as shown below according to the combination of the IOSY bit* in TCRXY of TMT_Y, the OS3 to OS0 bits in TCSR_Y, and the PF7DDR bit.

IOSY*	0		1		
	—		All 0		Not all 0
PF7DDR	0	1	0	1	—
Pin Function	PF7 input pin	PF7 output pin	PF7 input pin	PF7 output pin	TMOY output pin*

Notes: * The program development tool (emulator) does not support this function.

- PF6/ExTMOX

The pin function is switched as shown below according to the combination of the IOSX bit* in TCRXY of TMR_X, the OS3 to OS0 bits in TCSR_X, and the PF6DDR bit.

IOSX*	0		1		
OS3 to OS0	—		All 0		Not all 0
PF6DDR	0	1	0	1	—
Pin Function	PF6 input pin	PF6 output pin	PF6 input pin	PF6 output pin	ExTMOX output pin*

Notes: * The program development tool (emulator) does not support this function.

- PF5/ExTMIY

The pin function is switched as shown below according to the state of the PF5DDR bit.

PF5DDR	0		1	
Pin Function	PF5 input pin		PF5 output pin	
	ExTMIY input pin *			

Note: * The program development tool (emulator) does not support this function. When the IOSY bit is set to 1, this pin can be used as the ExTMIY input pin.

- PF4/ExTMIX

The pin function is switched as shown below according to the state of the PF4DDR bit.

PF4DDR	0		1	
Pin Function	PF4 input pin		PF4 output pin	
	ExTMIX input pin*			

Note: * The program development tool (emulator) does not support this function. When the IOSX bit is set to 1, this pin can be used as the ExTMIX input pin.

- PF3/TMOB

The pin function is switched as shown below according to the combination of the OS3 to OS0 bits in TCSR_B of TMR_B and the PF3DDR bit.

OS3 to OS0	All 0		Not all 0	
PF3DDR	0	1	—	
Pin Function	PF3 input pin	PF3 output pin	TMOB output pin	

- PF2/TMOA

The pin function is switched as shown below according to the combination of the OS3 to OS0 bits in TCSR_A of TMR_A and the PF2DDR bit.

OS3 to OS0	All 0		Not all 0
PF3DDR	0	1	—
Pin Function	PF2 input pin	PF2 output pin	TMOA output pin

- PF1/TMIB

The pin function is switched as shown below according to the state of the PF1DDR bit.

PF1DDR	0	1
Pin Function	PF1 input pin	PF1 output pin
	TMIB input pin*	

Note: * This pin can always be used as the TMIB input pin.

- PF0/TMIA

The pin function is switched as shown below according to the state of the PF0DDR bit.

PF0DDR	0	1
Pin Function	PF0 input pin	PF0 output pin
	TMIA input pin*	

Note: * This pin can always be used as the TMIA input pin.

7.13.5 Port E and Port F Nch-OD Control Register (PENOCR, PFNOCR)

PENOCR and PFNOCR specify the output driver type for pins on ports E and F which are configured as outputs on a bit-by-bit basis.

Bit	Bit Name	Initial Value	R/W	Description
7	PE7NOCR	0	R/W	0: CMOS (p-channel driver enabled)
6	PE6NOCR	0	R/W	1: N-channel open drain (p-channel driver disabled)
5	PE5NOCR	0	R/W	
4	PE4NOCR	0	R/W	
3	PE3NOCR	0	R/W	
2	PE2NOCR	0	R/W	
1	PE1NOCR	0	R/W	
0	PE0NOCR	0	R/W	

Bit	Bit Name	Initial Value	R/W	Description
7	PF7NOCR	0	R/W	0: CMOS (p-channel driver enabled)
6	PF6NOCR	0	R/W	1: N-channel open drain (p-channel driver disabled)
5	PF5NOCR	0	R/W	
4	PF4NOCR	0	R/W	
3	PF3NOCR	0	R/W	
2	PF2NOCR	0	R/W	
1	PF1NOCR	0	R/W	
0	PF0NOCR	0	R/W	

7.13.6 Pin Functions

DDR	0		1			
NOCR	—		0		1	
ODR	0	1	0	1	0	1
N-ch. driver	OFF		ON	OFF	ON	OFF
P-ch. driver	OFF		OFF	ON	OFF	
Input pull-up MOS	OFF	ON	OFF			
Pin function	Input pin		Output pin*			

Note: * Includes when set as the timer output pin.

7.13.7 Input Pull-Up MOS in Ports E and F

Port E and port F have an on-chip input pull-up MOS function that can be controlled by software. This input pull-up MOS function can be switched on or off on a bit-by-bit basis.

Table 7.9 is a summary of the input pull-up MOS states.

Table 7.9 Input Pull-Up MOS States (Port E and port F)

Reset	Hardware Standby Mode	Software Standby Mode	Other Operations
Off	Off	On/Off	On/Off

[Legend]

Off: Input pull-up MOS is always off.

On/Off: On when PEDDR = 0 and PEODR = 1 (PFDDR = 0 and PFODR = 1) with the pin in input state; otherwise off.

7.14 Port G

Port G is an 8-bit I/O port. Port G pins also function as IIC_0 and IIC_1 I/O pins. The output type of port G is NMOS push-pull output. The output type of ExSCLB*, ExSDAB*, ExSCLA*, and ExSDAA* is NMOS open-drain output and the pins can directly drive the bus. Port G has the following registers. For details of PGCTL, see section 13.3.9, Port G Control Register (PGCTL).

- Port G data direction register (PGDDR)
- Port G output data register (PGODR)
- Port G input data register (PGPIN)
- Port G Nch-OD control register (PGNOCR)
- Port G control register (PGCTL)*

Note: * The program development tool (emulator) does not support this function.

7.14.1 Port G Data Direction Register (PGDDR)

PGDDR selects input or output for the pins of port G on a bit-by-bit basis.

Bit	Bit Name	Initial Value	R/W	Description
7	PG7DDR	0	W	0: Port G pin is an input pin
6	PG6DDR	0	W	1: Port G pin is an output pin
5	PG5DDR	0	W	PGDDR has the same address as PGPIN, and if read, the port G pin states will be returned.
4	PG4DDR	0	W	
3	PG3DDR	0	W	
2	PG2DDR	0	W	
1	PG1DDR	0	W	
0	PG0DDR	0	W	

7.14.2 Port G Output Data Register (PGODR)

PGODR stores output data for the pins on port G.

Bit	Bit Name	Initial Value	R/W	Description
7	PG7ODR	0	R/W	PGODR can always be read or written to, regardless of the contents of PGDDR.
6	PG6ODR	0	R/W	
5	PG5ODR	0	R/W	
4	PG4ODR	0	R/W	
3	PG3ODR	0	R/W	
2	PG2ODR	0	R/W	
1	PG1ODR	0	R/W	
0	PG0ODR	0	R/W	

7.14.3 Port G Input Data Register (PGPIN)

Reading PGPIN always returns the pin states.

Bit	Bit Name	Initial Value	R/W	Description
7	PG7PIN	Undefined*	R	PGPIN indicates the port G state. PGPIN has the same address as PGDDR. If a write is performed, the port G settings will change.
6	PG6PIN	Undefined*	R	
5	PG5PIN	Undefined*	R	
4	PG4PIN	Undefined*	R	
3	PG3PIN	Undefined*	R	
2	PG2PIN	Undefined*	R	
1	PG1PIN	Undefined*	R	
0	PG0PIN	Undefined*	R	

Note: * The initial value is determined according to the PG7 to PG0 pin states.

7.14.4 Pin Functions

- PG7/ExSCLB

The pin function is switched as shown below according to the combination of the IIC1BS and the IIC0BS bits in PGCTL of the IIC* and the PG7DDR bit.

IIC1BS and IIC0BS*	All 0		Not all 0
PG7DDR	0	1	—
Pin Function	PG7 input pin	PG7 output pin	ExSCLB I/O pin*

Note: * The program development tool (emulator) does not support this function. The output type of ExSCLB is NMOS open-drain output and this pin has direct bus drive capability.

- PG6/ExSDAB

The pin function is switched as shown below according to the combination of the IIC1BS and the IIC0BS bits in PGCTL of the IIC* and the PG6DDR bit.

IIC1BS and IIC0BS*	All 0		Not all 0
PG6DDR	0	1	—
Pin Function	PG6 input pin	PG6 output pin	ExSDAB I/O pin*

Note: * The program development tool (emulator) does not support this function. The output type of ExSDAB is NMOS open-drain output and this pin has direct bus drive capability.

- PG5/ExSCLA

The pin function is switched as shown below according to the combination of the IIC1AS and the IIC0AS bits in PGCTL of the IIC* and the PG5DDR bit.

IIC1AS and IIC0AS*	All 0		Not all 0
PG5DDR	0	1	—
Pin Function	PG5 input pin	PG5 output pin	ExSCLA I/O pin*

Note: * The program development tool (emulator) does not support this function. The output type of ExSCLA is NMOS open-drain output and this pin has direct bus drive capability.

- PG4/ExSDAA

The pin function is switched as shown below according to the combination of the IIC1AS and the IIC0AS bits in PGCTL of the IIC* and the PG4DDR bit.

IIC1AS and IIC0AS*	All 0		Not all 0
PG4DDR	0	1	—
Pin Function	PG4 input pin	PG4 output pin	ExSDAA I/O pin*

Note: * The program development tool (emulator) does not support this function. The output type of ExSDAA is NMOS open-drain output and this pin has direct bus drive capability.

- PG3, PG2, PG1, PG0

The pin function is switched as shown below according to the state of the PGnDDR bit.

PGnDDR	0	1
Pin Function	PGn input pin	PGn output pin

[Legend]

n = 3 to 0

7.14.5 Port G Nch-OD Control Register (PGNOCR)

PGNOCR specifies the output driver type for pins on port G which are configured as outputs on a bit-by-bit basis.

Bit	Bit Name	Initial Value	R/W	Description
7	PG7NOCR	0	R/W	0: NMOS push-pull (Vcc-side n-channel driver enabled)
6	PG6NOCR	0	R/W	1: Vss-side N-channel open drain (Vcc-side N-channel driver disabled)
5	PG5NOCR	0	R/W	
4	PG4NOCR	0	R/W	
3	PG3NOCR	0	R/W	
2	PG2NOCR	0	R/W	
1	PG1NOCR	0	R/W	
0	PG0NOCR	0	R/W	

7.14.6 Pin Functions

DDR	0		1			
NOCR	—		0		1	
ODR	0	1	0	1	0	1
V _{ss} -side N-ch. driver	OFF		ON	OFF	ON	OFF
V _{cc} -side N-ch. driver	OFF		OFF	ON	OFF	
Pin function	Input pin		Output pin*			

Note: * Except when set as IIC I/O pin.

Section 8 8-Bit PWM Timer (PWM)

This LSI has an on-chip pulse width modulation (PWM) timer with eight outputs. Eight output waveforms are generated from a common time base, enabling PWM output with a high carrier frequency to be produced using pulse division. Connecting a low pass filter externally to the LSI enables the PWM to function as an 8-bit D/A converter.

8.1 Features

- Operable at a maximum carrier frequency of 625 kHz using pulse division (at 10 MHz operation)
- Duty cycles from 0 to 100% with 1/256 resolution (100% duty realized by port output)
- Direct or inverted PWM output, and PWM output enable/disable control

Figure 8.1 shows a block diagram of the PWM timer.

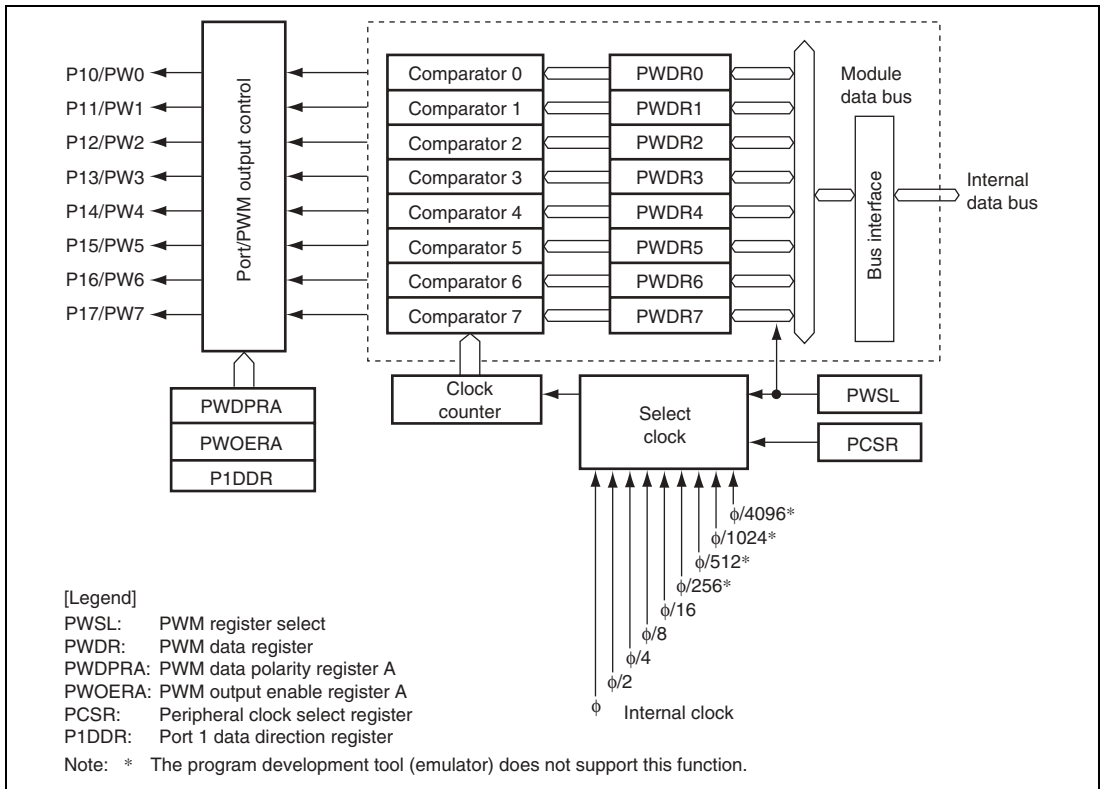

Figure 8.1 Block Diagram of PWM Timer

8.2 Input/Output Pins

Table 8.1 shows the PWM output pins.

Table 8.1 Pin Configuration

Name	Abbreviation	I/O	Function
PWM output 7 to 0	PW7 to PW0	Output	PWM timer pulse output 7 to 0

8.3 Register Descriptions

The PWM has the following registers. To access PCSR, the FLSHE bit in the serial timer control register (STCR) must be cleared to 0. For details on the serial timer control register (STCR), see section 3.2.3, Serial Timer Control Register (STCR).

- PWM register select (PWSL)
- PWM data registers 7 to 0 (PWDR7 to PWDR0)
- PWM data polarity register A (PWPRA)
- PWM output enable register A (PWOERA)
- Peripheral clock select register (PCSR)

8.3.1 PWM Register Select (PWSL)

PWSL is used to select the input clock and the PWM data register.

Bit	Bit Name	Initial Value	R/W	Description
7	PWCKE	0	R/W	PWM Clock Enable
6	PWCKS	0	R/W	PWM Clock Select These bits, together with bits PWCKC, PWCKB and PWCKA in PCSR, select the internal clock input to TCNT in the PWM. For details, see table 8.2. The resolution, PWM conversion period, and carrier frequency depend on the selected internal clock, and can be obtained from the following equations. Resolution (minimum pulse width) = 1/internal clock frequency PWM conversion period = resolution × 256 Carrier frequency = 16/PWM conversion period With a 10 MHz system clock (ϕ), the resolution, PWM conversion period, and carrier frequency are as shown in table 8.3.
5	—	1	R	Reserved Always read as 1 and cannot be modified.
4	—	0	R	Reserved Always read as 0 and cannot be modified.
3	RS3	0	R/W	Register Select
2	RS2	0	R/W	These bits select the PWM data register.
1	RS1	0	R/W	0000: PWDR0 selected
0	RS0	0	R/W	0001: PWDR1 selected 0010: PWDR2 selected 0011: PWDR3 selected 0100: PWDR4 selected 0101: PWDR5 selected 0110: PWDR6 selected 0111: PWDR7 selected 1xxx: No effect on operation

[Legend]

x: Don't care.

Table 8.2 Internal Clock Selection

PWSL		PCSR			Description
PWCKE	PWCKS	PWCKC	PWCKB	PWCKA	
0	—	—	—	—	Clock input is disabled (Initial value)
1	0	—	—	—	ϕ (system clock) is selected
	1	0	0	0	$\phi/2$ is selected
		0	0	1	$\phi/4$ is selected
		0	1	0	$\phi/8$ is selected
		0	1	1	$\phi/16$ is selected
		1	0	0	$\phi/256$ is selected*
		1	0	1	$\phi/512$ is selected*
		1	1	0	$\phi/1024$ is selected*
		1	1	1	$\phi/4096$ is selected*

Note: * The program development tool (emulator) does not support this function.

Table 8.3 Resolution, PWM Conversion Period, and Carrier Frequency when $\phi = 10$ MHz

Internal Clock Frequency	Resolution	PWM Conversion Period	Carrier Frequency
ϕ	100 ns	25.6 μ s	625 kHz
$\phi/2$	200 ns	51.2 μ s	312.5 kHz
$\phi/4$	400 ns	102 μ s	156.3 kHz
$\phi/8$	800 ns	205 μ s	78.1 kHz
$\phi/16$	1.6 μ s	410 μ s	39.1 kHz
$\phi/256^*$	25.6 μ s	6.55 ms	2.4 kHz
$\phi/512^*$	51.2 μ s	13.1 ms	1.2 kHz
$\phi/1024^*$	102 μ s	26.2 ms	610 kHz
$\phi/4096^*$	410 μ s	105 ms	152 kHz

Note: * The program development tool (emulator) does not support this function.

8.3.2 PWM Data Registers 7 to 0 (PWDR7 to PWD0)

PWDR are 8-bit readable/writable registers. The PWM has eight PWM data registers. Each PWDR specifies the duty cycle of the basic pulse to be output, and the number of additional pulses. The value set in PWDR corresponds to a 0 or 1 ratio in the conversion period. The upper four bits specify the duty cycle of the basic pulse as 0/16 to 15/16 with a resolution of 1/16. The lower four bits specify how many extra pulses are to be added within the conversion period comprising 16 basic pulses. Thus, a specification of 0/256 to 255/256 is possible for 0/1 ratios within the conversion period. For 256/256 (100%) output, port output should be used.

8.3.3 PWM Data Polarity Register A (PWDPRA)

PWDPRA selects the PWM output phase.

Bit	Bit Name	Initial Value	R/W	Description
7	OS7	0	R/W	Output Select 7 to 0
6	OS6	0	R/W	These bits select the PWM output phase. Bits OS7 to OS0 correspond to outputs PW7 to PW0.
5	OS5	0	R/W	
4	OS4	0	R/W	0: PWM direct output (PWDR value corresponds to high width of output) 1: PWM inverted output (PWDR value corresponds to low width of output)
3	OS3	0	R/W	
2	OS2	0	R/W	
1	OS1	0	R/W	
0	OS0	0	R/W	

8.3.4 PWM Output Enable Register A (PWOERA)

PWOERA switches between PWM output and port output.

Bit	Bit Name	Initial Value	R/W	Description
7	OE7	0	R/W	Output Enable 7 to 0
6	OE6	0	R/W	These bits, together with P1DDR, specify the P1n/PWn pin state. Bits OE7 to OE0 correspond to outputs PW7 to PW0.
5	OE5	0	R/W	
4	OE4	0	R/W	P1nDDR OEn: Pin state 0 x: Port input
3	OE3	0	R/W	
2	OE2	0	R/W	1 0: Port output or PWM 256/256 output 1 1: PWM output (0 to 255/256 output)
1	OE1	0	R/W	
0	OE0	0	R/W	

[Legend]

x: Don't care

Note: n = 7 to 0

To perform PWM 256/256 output when DDR = 1 and OE = 0, the corresponding pin should be set to port output.

DR data is output when the corresponding pin is used as port output. A value corresponding to PWM 256/256 output is determined by the OS bit, so the value should have been set to DR beforehand.

8.3.5 Peripheral Clock Select Register (PCSR)

PCSR selects the PWM input clock.

Bit	Bit Name	Initial Value	R/W	Description
7 to 4	—	All 0	R/W	Reserved These bits cannot be modified.
3	PWCKC*	0	R/W	PWM Clock Select C, B, A
2	PWCKB	0	R/W	Together with bits PWCKE and PWCKS in PWSL, these bits select the internal clock input to the clock counter in the PWM. For details, see table 8.2.
1	PWCKA	0	R/W	
0	—	0	R/W	Reserved These bits cannot be modified.

Note: The program development tool (emulator) does not support this function.

8.4 Operation

The upper four bits of PWDR specify the duty cycle of the basic pulse as 0/16 to 15/16 with a resolution of 1/16. Table 8.4 shows the duty cycles of the basic pulse.

Table 8.4 Duty Cycle of Basic Pulse

Upper 4 Bits	Basic Pulse Waveform (Internal)
B'0000	H: 0 1 2 3 4 5 6 7 8 9 A B C D E F 0 L: _____
B'0001	
B'0010	
B'0011	
B'0100	
B'0101	
B'0110	
B'0111	
B'1000	
B'1001	
B'1010	
B'1011	
B'1100	
B'1101	
B'1110	
B'1111	

The lower four bits of PWDR specify the position of pulses added to the 16 basic pulses. An additional pulse adds a high period (when OS = 0) with a width equal to the resolution before the rising edge of a basic pulse. When the upper four bits of PWDR are B'0000, there is no rising edge of the basic pulse, but the timing for adding pulses is the same. Table 8.5 shows the positions of the additional pulses added to the basic pulses, and figure 8.2 shows an example of additional pulse timing.

Table 8.5 Position of Pulses Added to Basic Pulses

Lower 4 Bits	Basic Pulse No.															
	0	1	2	3	4	5	6	7	8	9	10	11	12	13	14	15
B'0000																
B'0001																Yes
B'0010								Yes								Yes
B'0011								Yes			Yes					Yes
B'0100				Yes				Yes			Yes					Yes
B'0101				Yes				Yes			Yes		Yes			Yes
B'0110				Yes	Yes			Yes			Yes		Yes			Yes
B'0111				Yes	Yes	Yes		Yes	Yes		Yes		Yes	Yes		Yes
B'1000		Yes	Yes	Yes	Yes	Yes	Yes	Yes	Yes	Yes	Yes	Yes	Yes	Yes	Yes	Yes
B'1001		Yes	Yes	Yes	Yes	Yes	Yes	Yes	Yes	Yes	Yes	Yes	Yes	Yes	Yes	Yes
B'1010		Yes	Yes	Yes	Yes	Yes	Yes	Yes	Yes	Yes	Yes	Yes	Yes	Yes	Yes	Yes
B'1011		Yes	Yes	Yes	Yes	Yes	Yes	Yes	Yes	Yes	Yes	Yes	Yes	Yes	Yes	Yes
B'1100		Yes	Yes	Yes	Yes	Yes	Yes	Yes	Yes	Yes	Yes	Yes	Yes	Yes	Yes	Yes
B'1101		Yes	Yes	Yes	Yes	Yes	Yes	Yes	Yes	Yes	Yes	Yes	Yes	Yes	Yes	Yes
B'1110		Yes	Yes	Yes	Yes	Yes	Yes	Yes	Yes	Yes	Yes	Yes	Yes	Yes	Yes	Yes
B'1111		Yes	Yes	Yes	Yes	Yes	Yes	Yes	Yes	Yes	Yes	Yes	Yes	Yes	Yes	Yes

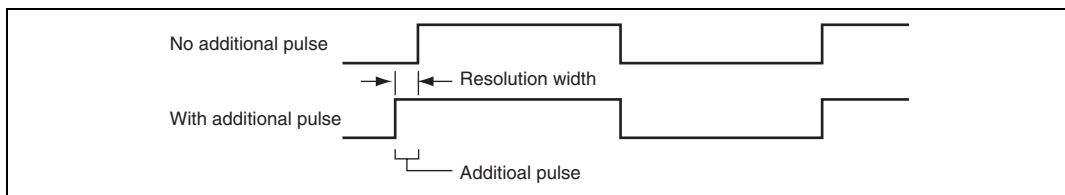

Figure 8.2 Example of Additional Pulse Timing (When Upper 4 Bits of PWDR = B'1000)

8.4.1 PWM Setting Example

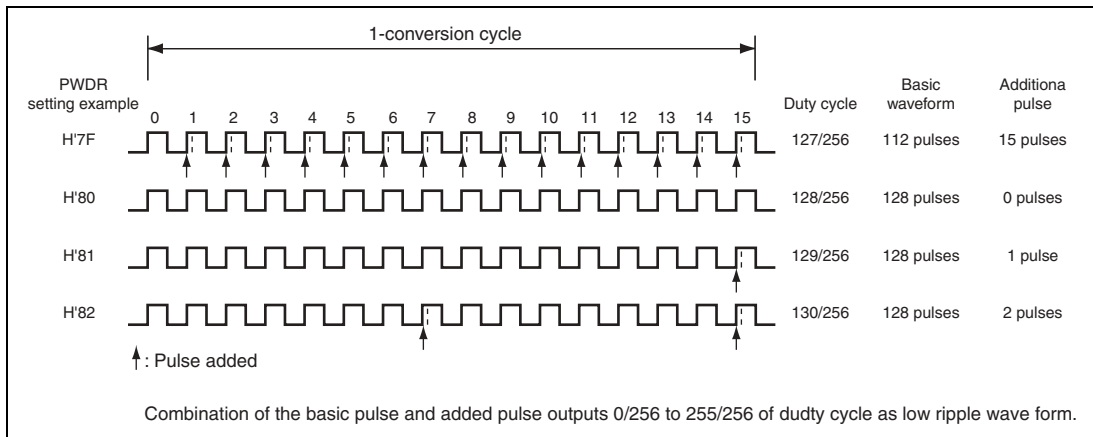

Figure 8.3 Example of PWM Setting

8.4.2 Diagram of PWM Used as D/A Converter

Figure 8.4 shows the diagram example when using the PWM pulse as the D/A converter. Analog signal with low ripple can be generated by connecting the low pass filter.

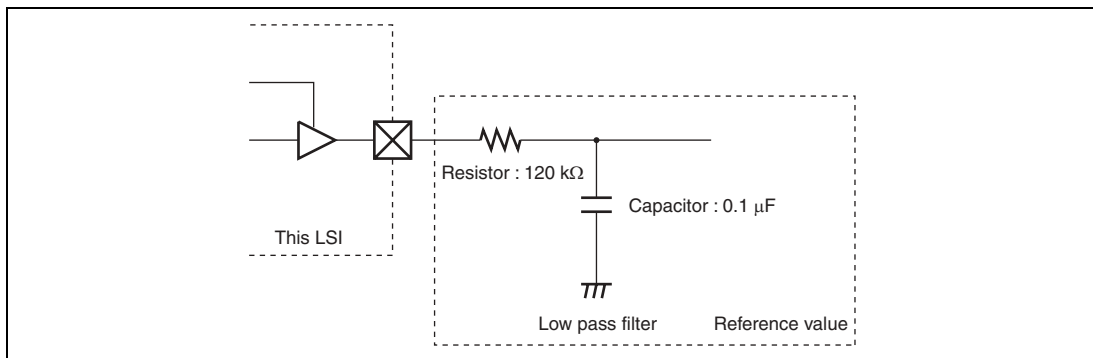

Figure 8.4 Example when PWM is Used as D/A Converter

8.5 Usage Notes

8.5.1 Module Stop Mode Setting

PWM operation can be enabled or disabled by the module stop control register. In the initial state, PWM operation is disabled. Access to PWM registers is enabled when module stop mode is cancelled. For details, see section 20, Power-Down Modes.

Section 9 16-Bit Free-Running Timer (FRT)

This LSI has an on-chip 16-bit free-running timer (FRT). The FRT operates on the basis of the 16-bit free-running counter (FRC), and outputs two independent waveforms, and measures the input pulse width and external clock periods.

9.1 Features

- Selection of four clock sources
One of the three internal clocks ($\phi/2$, $\phi/8$, or $\phi/32$), or an external clock input can be selected (enabling use as an external event counter).
- Two independent comparators
Two independent waveforms can be output.
- Four independent input capture channels
The rising or falling edge can be selected.
Buffer modes can be specified.
- Counter clearing
The free-running counters can be cleared on compare-match A.
- Seven independent interrupts
Two compare-match interrupts, four input capture interrupts, and one overflow interrupt can be requested independently.
- Special functions provided by automatic addition function
The contents of OCRAR and OCRAF can be added to the contents of OCRA automatically, enabling a periodic waveform to be generated without software intervention. The contents of ICRD can be added automatically to the contents of OCRDM $\times 2$, enabling input capture operations in this interval to be restricted.

Figure 9.1 shows a block diagram of the FRT.

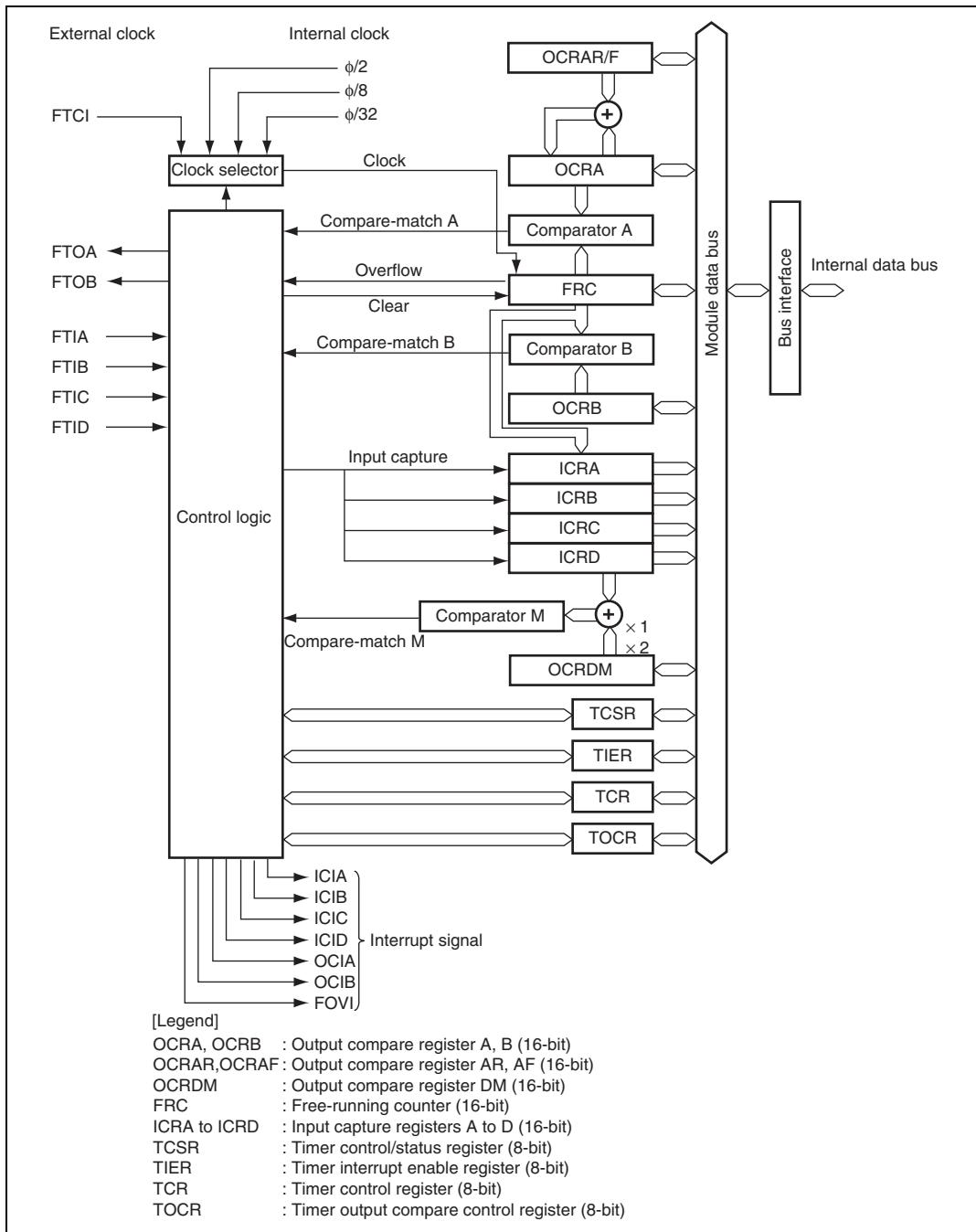

Figure 9.1 Block Diagram of 16-Bit Free-Running Timer

9.2 Input/Output Pins

Table 9.1 lists the FRT input and output pins.

Table 9.1 Pin Configuration

Name	Abbreviation	I/O	Function
Counter clock input pin	FTCI	Input	FRC counter clock input
Output compare A output pin	FTOA	Output	Output compare A output
Output compare B output pin	FTOB	Output	Output compare B output
Input capture A input pin	FTIA	Input	Input capture A input
Input capture B input pin	FTIB	Input	Input capture B input
Input capture C input pin	FTIC	Input	Input capture C input
Input capture D input pin	FTID	Input	Input capture D input

9.3 Register Descriptions

The FRT has the following registers.

- Free-running counter (FRC)
- Output compare register A (OCRA)
- Output compare register B (OCRB)
- Input capture register A (ICRA)
- Input capture register B (ICRB)
- Input capture register C (ICRC)
- Input capture register D (ICRD)
- Output compare register AR (OCRAR)
- Output compare register AF (OCRAF)
- Output compare register DM (OCRDM)
- Timer interrupt enable register (TIER)
- Timer control/status register (TCSR)
- Timer control register (TCR)
- Timer output compare control register (TOCR)

Note: OCRA and OCRB share the same address. Register selection is controlled by the OCRS bit in TOCR. ICRA, ICRB, and ICRC share the same addresses with OCRAR, OCRAF, and OCRDM. Register selection is controlled by the ICRS bit in TOCR.

9.3.1 Free-Running Counter (FRC)

FRC is a 16-bit readable/writable up-counter. The clock source is selected by bits CKS1 and CKS0 in TCR. FRC can be cleared by compare-match A. When FRC overflows from H'FFFF to H'0000, the overflow flag bit (OVF) in TCSR is set to 1. FRC should always be accessed in 16-bit units; cannot be accessed in 8-bit units. FRC is initialized to H'0000.

9.3.2 Output Compare Registers A and B (OCRA, OCRB)

The FRT has two output compare registers, OCRA and OCRB, each of which is a 16-bit readable/writable register whose contents are continually compared with the value in FRC. When a match is detected (compare-match), the corresponding output compare flag (OCFA or OCFB) is set to 1 in TCSR. If the OEA or OEB bit in TOCR is set to 1, when the OCR and FRC values match, the output level selected by the OLVLA or OLVLB bit in TOCR is output at the output compare output pin (FTOA or FTOB). Following a reset, the FTOA and FTOB output levels are 0 until the first compare-match. OCR should always be accessed in 16-bit units; cannot be accessed in 8-bit units. OCR is initialized to H'FFFF.

9.3.3 Input Capture Registers A to D (ICRA to ICRD)

The FRT has four input capture registers, ICRA to ICRD, each of which is a 16-bit read-only register. When the rising or falling edge of the signal at an input capture input pin (FTIA to FTID) is detected, the current FRC value is transferred to the corresponding input capture register (ICRA to ICRD). At the same time, the corresponding input capture flag (ICFA to ICFD) in TCSR is set to 1. The FRC contents are transferred to ICR regardless of the value of ICF. The input capture edge is selected by the input edge select bits (IEDGA to IEDGD) in TCR.

ICRC and ICRD can be used as ICRA and ICRB buffer registers, respectively, by means of buffer enable bits A and B (BUFEA and BUFEB) in TCR. For example, if an input capture occurs when ICRC is specified as the ICRA buffer register, the FRC contents are transferred to ICRA, and then transferred to the buffer register ICRC.

To ensure input capture, the input capture pulse width should be at least 1.5 system clocks (ϕ) for a single edge. When triggering is enabled on both edges, the input capture pulse width should be at least 2.5 system clocks (ϕ).

ICRA to ICRD should always be accessed in 16-bit units; cannot be accessed in 8-bit units. ICR is initialized to H'0000.

9.3.4 Output Compare Registers AR and AF (OCRAR, OCRAF)

OCRAR and OCRAF are 16-bit readable/writable registers. When the OCRAMS bit in TOCR is set to 1, the operation of OCRA is changed to include the use of OCRAR and OCRAF. The contents of OCRAR and OCRAF are automatically added alternately to OCRA, and the result is written to OCRA. The write operation is performed on the occurrence of compare-match A. In the 1st compare-match A after setting the OCRAMS bit to 1, OCRAF is added. The operation due to compare-match A varies according to whether the compare-match follows addition of OCRAR or OCRAF. The value of the OLVLA bit in TOCR is ignored, and 1 is output on a compare-match A following addition of OCRAF, while 0 is output on a compare-match A following addition of OCRAR.

When using the OCRA automatic addition function, do not select internal clock $\phi/2$ as the FRC input clock together with a set value of H'0001 or less for OCRAR (or OCRAF).

OCRAR and OCRAF should always be accessed in 16-bit units; cannot be accessed in 8-bit units. OCRAR and OCRAF are initialized to H'FFFF.

9.3.5 Output Compare Register DM (OCRDM)

OCRDM is a 16-bit readable/writable register in which the upper 8 bits are fixed at H'00. When the ICRDMS bit in TOCR is set to 1 and the contents of OCRDM are other than H'0000, the operation of ICRD is changed to include the use of OCRDM. The point at which input capture D occurs is taken as the start of a mask interval. Next, twice the contents of OCRDM is added to the contents of ICRD, and the result is compared with the FRC value. The point at which the values match is taken as the end of the mask interval. New input capture D events are disabled during the mask interval. A mask interval is not generated when the contents of OCRDM are H'0000 while the ICRDMS bit is set to 1.

OCRDM should always be accessed in 16-bit units; cannot be accessed in 8-bit units. OCRDM is initialized to H'0000.

9.3.6 Timer Interrupt Enable Register (TIER)

TIER enables and disables interrupt requests.

Bit	Bit Name	Initial Value	R/W	Description
7	ICIAE	0	R/W	<p>Input Capture Interrupt A Enable</p> <p>Selects whether to enable input capture interrupt A request (ICIA) when input capture flag A (ICFA) in TCSR is set to 1.</p> <p>0: ICIA requested by ICFA is disabled</p> <p>1: ICIA requested by ICFA is enabled</p>
6	ICIBE	0	R/W	<p>Input Capture Interrupt B Enable</p> <p>Selects whether to enable input capture interrupt B request (ICIB) when input capture flag B (ICFB) in TCSR is set to 1.</p> <p>0: ICIB requested by ICFB is disabled</p> <p>1: ICIB requested by ICFB is enabled</p>
5	ICICE	0	R/W	<p>Input Capture Interrupt C Enable</p> <p>Selects whether to enable input capture interrupt C request (ICIC) when input capture flag C (ICFC) in TCSR is set to 1.</p> <p>0: ICIC requested by ICFC is disabled</p> <p>1: ICIC requested by ICFC is enabled</p>
4	ICIDE	0	R/W	<p>Input Capture Interrupt D Enable</p> <p>Selects whether to enable input capture interrupt D request (ICID) when input capture flag D (ICFD) in TCSR is set to 1.</p> <p>0: ICID requested by ICFD is disabled</p> <p>1: ICID requested by ICFD is enabled</p>
3	OCIAE	0	R/W	<p>Output Compare Interrupt A Enable</p> <p>Selects whether to enable output compare interrupt A request (OCIA) when output compare flag A (OCFA) in TCSR is set to 1.</p> <p>0: OCIA requested by OCFA is disabled</p> <p>1: OCIA requested by OCFA is enabled</p>

Bit	Bit Name	Initial Value	R/W	Description
2	OCIBE	0	R/W	<p>Output Compare Interrupt B Enable</p> <p>Selects whether to enable output compare interrupt B request (OCIB) when output compare flag B (OCFB) in TCSR is set to 1.</p> <p>0: OCIB requested by OCFB is disabled 1: OCIB requested by OCFB is enabled</p>
1	OVIE	0	R/W	<p>Timer Overflow Interrupt Enable</p> <p>Selects whether to enable a free-running timer overflow request interrupt (FOVI) when the timer overflow flag (OVF) in TCSR is set to 1.</p> <p>0: FOVI requested by OVF is disabled 1: FOVI requested by OVF is enabled</p>
0	—	0	R	<p>Reserved</p> <p>This bit is always read as 1 and cannot be modified.</p>

9.3.7 Timer Control/Status Register (TCSR)

TCSR is used for counter clear selection and control of interrupt request signals.

Bit	Bit Name	Initial Value	R/W	Description
7	ICFA	0	R/(W)*	<p>Input Capture Flag A</p> <p>This status flag indicates that the FRC value has been transferred to ICRA by means of an input capture signal. When BUFEA = 1, ICFA indicates that the old ICRA value has been moved into ICRC and the new FRC value has been transferred to ICRA. Only 0 can be written to this bit to clear the flag.</p> <p>[Setting condition]</p> <p>When an input capture signal causes the FRC value to be transferred to ICRA</p> <p>[Clearing condition]</p> <p>Read ICFA when ICFA = 1, then write 0 to ICFA</p>

Bit	Bit Name	Initial Value	R/W	Description
6	ICFB	0	R/(W)*	<p>Input Capture Flag B</p> <p>This status flag indicates that the FRC value has been transferred to ICRB by means of an input capture signal. When BUFEB = 1, ICFB indicates that the old ICRB value has been moved into ICRD and the new FRC value has been transferred to ICRB. Only 0 can be written to this bit to clear the flag.</p> <p>[Setting condition]</p> <p>When an input capture signal causes the FRC value to be transferred to ICRB</p> <p>[Clearing condition]</p> <p>Read ICFB when ICFB = 1, then write 0 to ICFB</p>
5	ICFC	0	R/(W)*	<p>Input Capture Flag C</p> <p>This status flag indicates that the FRC value has been transferred to ICRC by means of an input capture signal. When BUFEA = 1, on occurrence of an input capture signal specified by the IEDGC bit at the FTIC input pin, ICFC is set but data is not transferred to ICRC. In buffer operation, ICFC can be used as an external interrupt signal by setting the ICICE bit to 1. Only 0 can be written to this bit to clear the flag.</p> <p>[Setting condition]</p> <p>When an input capture signal is received</p> <p>[Clearing condition]</p> <p>Read ICFC when ICFC = 1, then write 0 to ICFC</p>
4	ICFD	0	R/(W)*	<p>Input Capture Flag D</p> <p>This status flag indicates that the FRC value has been transferred to ICRD by means of an input capture signal. When BUFEB = 1, on occurrence of an input capture signal specified by the IEDGD bit at the FTID input pin, ICFD is set but data is not transferred to ICRD. In buffer operation, ICFD can be used as an external interrupt signal by setting the ICIDE bit to 1. Only 0 can be written to this bit to clear the flag.</p> <p>[Setting condition]</p> <p>When an input capture signal is received</p> <p>[Clearing condition]</p> <p>Read ICFD when ICFD = 1, then write 0 to ICFD</p>

Bit	Bit Name	Initial Value	R/W	Description
3	OCFA	0	R/(W)*	<p>Output Compare Flag A</p> <p>This status flag indicates that the FRC value matches the OCRA value. Only 0 can be written to this bit to clear the flag.</p> <p>[Setting condition] When FRC = OCRA</p> <p>[Clearing condition] Read OCFA when OCFA = 1, then write 0 to OCFA</p>
2	OCFB	0	R/(W)*	<p>Output Compare Flag B</p> <p>This status flag indicates that the FRC value matches the OCRB value. Only 0 can be written to this bit to clear the flag.</p> <p>[Setting condition] When FRC = OCRB</p> <p>[Clearing condition] Read OCFB when OCFB = 1, then write 0 to OCFB</p>
1	OVF	0	R/(W)*	<p>Timer Overflow</p> <p>This status flag indicates that the FRC has overflowed. Only 0 can be written to this bit to clear the flag.</p> <p>[Setting condition] When FRC overflows (changes from H'FFFF to H'0000)</p> <p>[Clearing condition] Read OVF when OVF = 1, then write 0 to OVF</p>
0	CCLRA	0	R/W	<p>Counter Clear A</p> <p>This bit selects whether the FRC is to be cleared at compare-match A (when the FRC and OCRA values match).</p> <p>0: FRC clearing is disabled 1: FRC is cleared at compare-match A</p>

Note: * Only 0 can be written to clear the flag.

9.3.8 Timer Control Register (TCR)

TCR selects the rising or falling edge of the input capture signals, enables the input capture buffer mode, and selects the FRC clock source.

Bit	Bit Name	Initial Value	R/W	Description
7	IEDGA	0	R/W	Input Edge Select A Selects the rising or falling edge of the input capture A signal (FTIA). 0: Capture on the falling edge of FTIA 1: Capture on the rising edge of FTIA
6	IEDGB	0	R/W	Input Edge Select B Selects the rising or falling edge of the input capture B signal (FTIB). 0: Capture on the falling edge of FTIB 1: Capture on the rising edge of FTIB
5	IEDGC	0	R/W	Input Edge Select C Selects the rising or falling edge of the input capture C signal (FTIC). 0: Capture on the falling edge of FTIC 1: Capture on the rising edge of FTIC
4	IEDGD	0	R/W	Input Edge Select D Selects the rising or falling edge of the input capture D signal (FTID). 0: Capture on the falling edge of FTID 1: Capture on the rising edge of FTID
3	BUFEA	0	R/W	Buffer Enable A Selects whether ICRC is to be used as a buffer register for ICRA. 0: ICRC is not used as a buffer register for ICRA 1: ICRC is used as a buffer register for ICRA
2	BUFEB	0	R/W	Buffer Enable B Selects whether ICRD is to be used as a buffer register for ICRB. 0: ICRD is not used as a buffer register for ICRB 1: ICRD is used as a buffer register for ICRB

Bit	Bit Name	Initial Value	R/W	Description
1	CKS1	0	R/W	Clock Select 1, 0
0	CKS0	0		Select clock source for FRC. 00: $\phi/2$ internal clock source 01: $\phi/8$ internal clock source 10: $\phi/32$ internal clock source 11: External clock source (counting at FTCl rising edge)

9.3.9 Timer Output Compare Control Register (TOCR)

TOCR enables output from the output compare pins, selects the output levels, switches access between output compare registers A and B, controls the ICRD and OCRA operating modes, and switches access to input capture registers A, B, and C.

Bit	Bit Name	Initial Value	R/W	Description
7	ICRDMS	0	R/W	Input Capture D Mode Select Specifies whether ICRD is used in the normal operating mode or in the operating mode using OCRDM. 0: The normal operating mode is specified for ICRD 1: The operating mode using OCRDM is specified for ICRD
6	OCRAMS	0	R/W	Output Compare A Mode Select Specifies whether OCRA is used in the normal operating mode or in the operating mode using OCRAR and OCRAF. 0: The normal operating mode is specified for OCRA 1: The operating mode using OCRAR and OCRAF is specified for OCRA
5	ICRS	0	R/W	Input Capture Register Select The same addresses are shared by ICRA and OCRAR, by ICRB and OCRAF, and by ICRC and OCRDM. The ICRS bit determines which registers are selected when the shared addresses are read from or written to. The operation of ICRA, ICRB, and ICRC is not affected. 0: ICRA, ICRB, and ICRC are selected 1: OCRAR, OCRAF, and OCRDM are selected

Bit	Bit Name	Initial Value	R/W	Description
4	OCRS	0	R/W	<p>Output Compare Register Select</p> <p>OCRA and OCRB share the same address. When this address is accessed, the OCRS bit selects which register is accessed. The operation of OCRA or OCRB is not affected.</p> <p>0: OCRA is selected</p> <p>1: OCRB is selected</p>
3	OEA	0	R/W	<p>Output Enable A</p> <p>Enables or disables output of the output compare A output pin (FTOA).</p> <p>0: Output compare A output is disabled</p> <p>1: Output compare A output is enabled</p>
2	OEB	0	R/W	<p>Output Enable B</p> <p>Enables or disables output of the output compare B output pin (FTOB).</p> <p>0: Output compare B output is disabled</p> <p>1: Output compare B output is enabled</p>
1	OLVLA	0	R/W	<p>Output Level A</p> <p>Selects the level to be output at the output compare A output pin (FTOA) in response to compare-match A (signal indicating a match between the FRC and OCRA values). When the OCRAMS bit is 1, this bit is ignored.</p> <p>0: 0 is output at compare-match A</p> <p>1: 1 is output at compare-match A</p>
0	OLVLB	0	R/W	<p>Output Level B</p> <p>Selects the level to be output at the output compare B output pin (FTOB) in response to compare-match B (signal indicating a match between the FRC and OCRB values).</p> <p>0: 0 is output at compare-match B</p> <p>1: 1 is output at compare-match B</p>

9.4 Operation

9.4.1 Pulse Output

Figure 9.2 shows an example of 50%-duty pulses output with an arbitrary phase difference. When a compare match occurs while the CCLRA bit in TCSR is set to 1, the OLVLA and OLVLB bits are inverted by software.

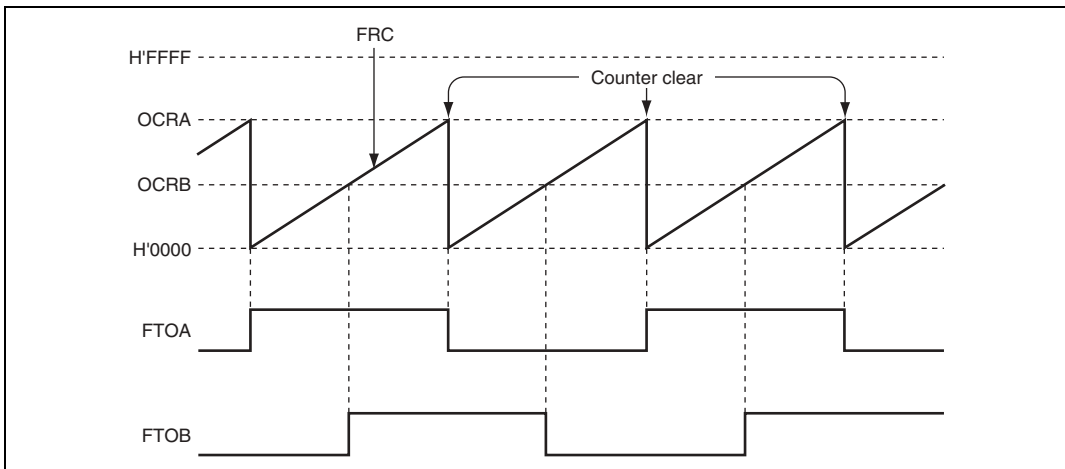

Figure 9.2 Example of Pulse Output

9.5 Operation Timing

9.5.1 FRC Increment Timing

Figure 9.3 shows the FRC increment timing with an internal clock source. Figure 9.4 shows the increment timing with an external clock source. The pulse width of the external clock signal must be at least 1.5 system clocks (ϕ). The counter will not increment correctly if the pulse width is shorter than 1.5 system clocks (ϕ).

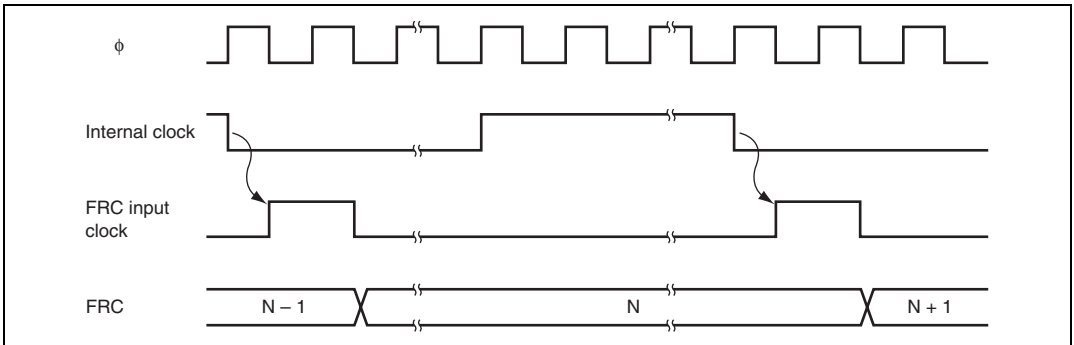

Figure 9.3 Increment Timing with Internal Clock Source

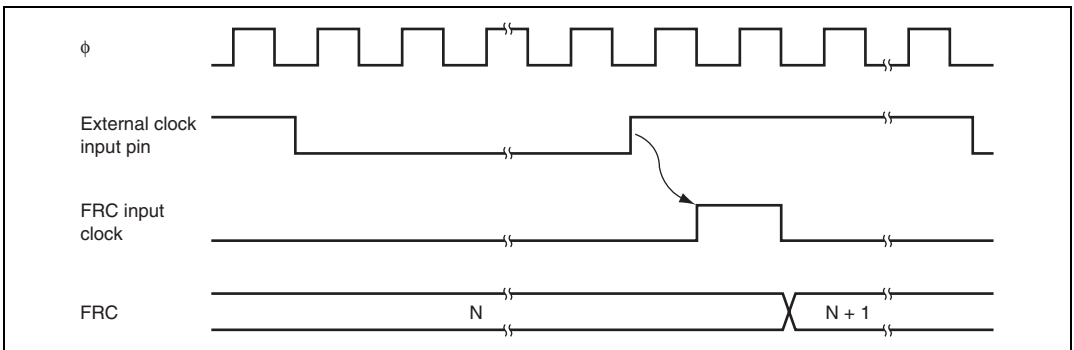

Figure 9.4 Increment Timing with External Clock Source

9.5.2 Output Compare Output Timing

A compare-match signal occurs at the last state when the FRC and OCR values match (at the timing when the FRC updates the counter value). When a compare-match signal occurs, the level selected by the OLVL bit in TOCR is output at the output compare pin (FTOA or FTOB). Figure 9.5 shows the timing of this operation for compare-match A.

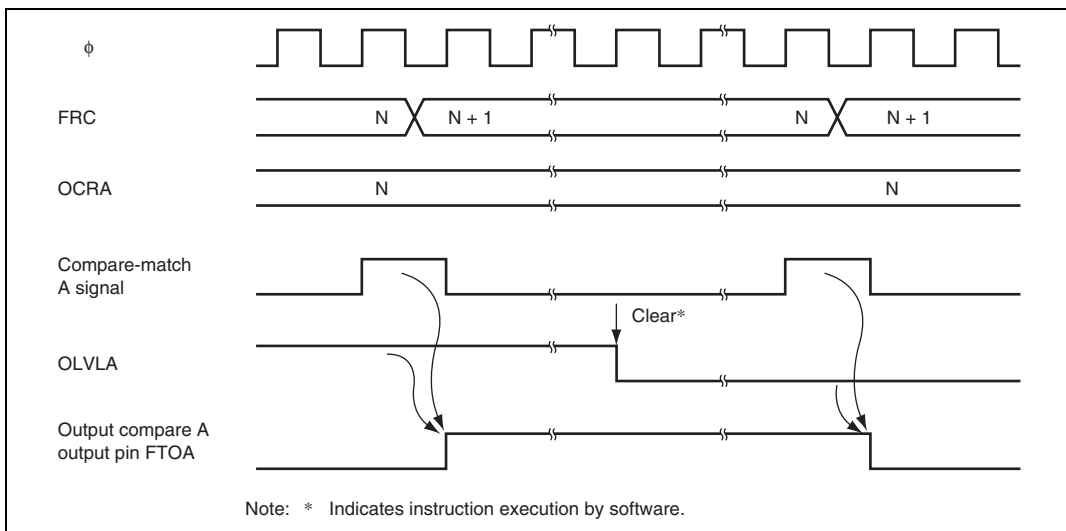

Figure 9.5 Timing of Output Compare A Output

9.5.3 FRC Clear Timing

FRC can be cleared when compare-match A occurs. Figure 9.6 shows the timing of this operation.

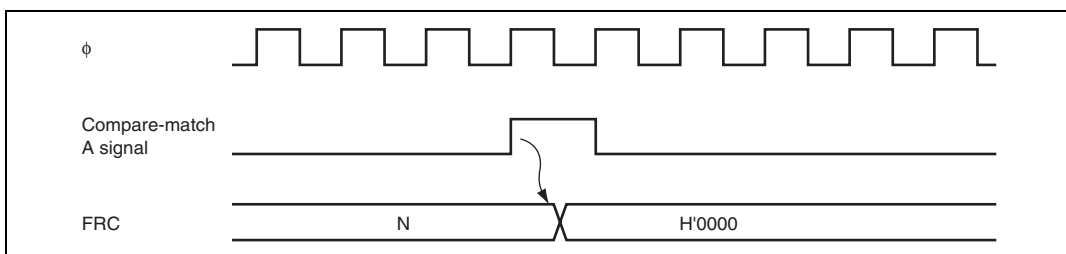

Figure 9.6 Clearing of FRC by Compare-Match A Signal

9.5.4 Input Capture Input Timing

The rising or falling edge can be selected for the input capture input timing by the IEDGA to IEDGD bits in TCR. Figure 9.7 shows the usual input capture timing when the rising edge is selected.

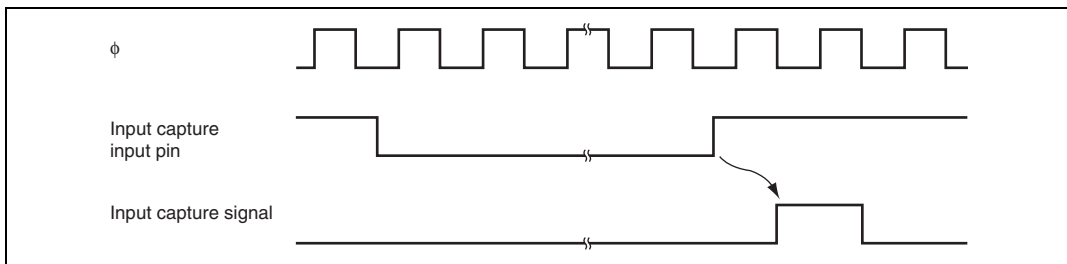

Figure 9.7 Input Capture Input Signal Timing (Usual Case)

If ICRA to ICRAD are read when the corresponding input capture signal arrives, the internal input capture signal is delayed by one system clock (ϕ). Figure 9.8 shows the timing for this case.

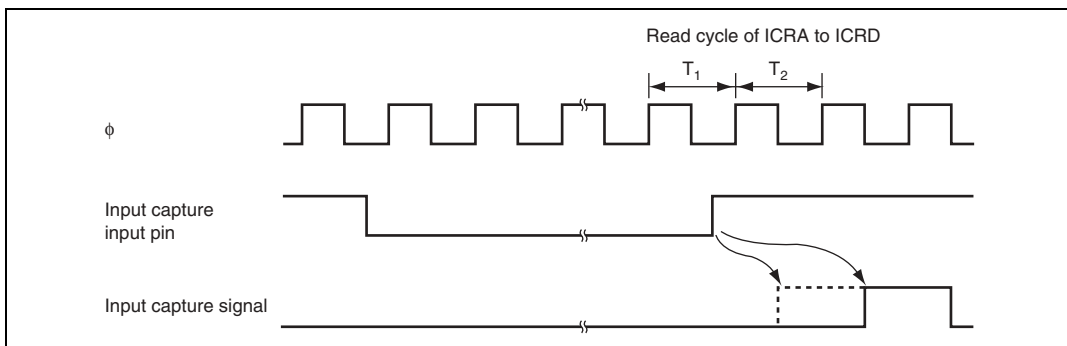

Figure 9.8 Input Capture Input Signal Timing (When ICRA to ICRD are Read)

9.5.5 Buffered Input Capture Input Timing

ICRC and ICRD can operate as buffers for ICRA and ICRB, respectively. Figure 9.9 shows how input capture operates when ICRC is used as ICRA's buffer register (BUFEA = 1) and IEDGA and IEDGC are set to different values (IEDGA = 0 and IEDGC = 1, or IEDGA = 1 and IEDGC = 0), so that input capture is performed on both the rising and falling edges of FTIA.

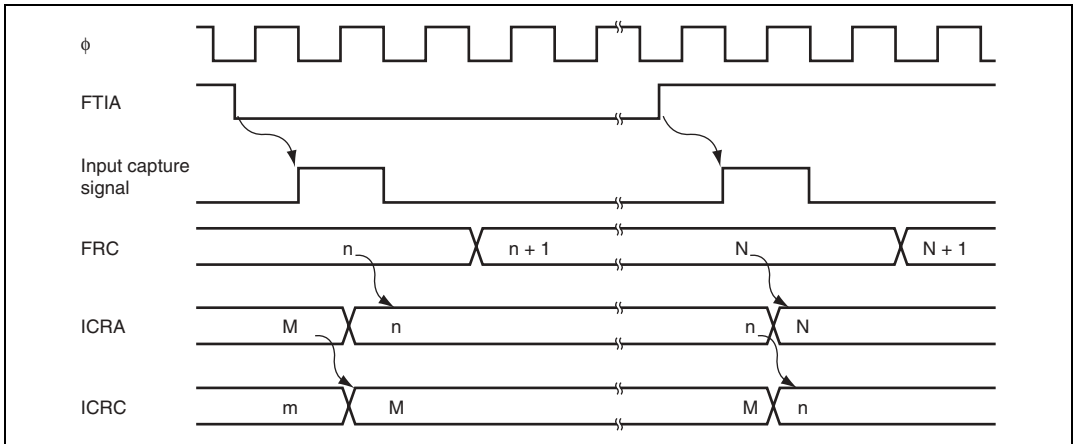

Figure 9.9 Buffered Input Capture Timing

Even when ICRC or ICRD is used as a buffer register, its input capture flag is set by the selected transition of its input capture signal. For example, if ICRC is used to buffer ICRA, when the edge transition selected by the IEDGC bit occurs on the FTIC input capture line, ICFC will be set, and if the ICICE bit is set at this time, an interrupt will be requested. The FRC value will not be transferred to ICRC, however. In buffered input capture, if either set of two registers to which data will be transferred (ICRA and ICRC, or ICRB and ICRD) is being read when the input capture input signal arrives, input capture is delayed by one system clock (ϕ). Figure 9.10 shows the timing when BUFEA = 1.

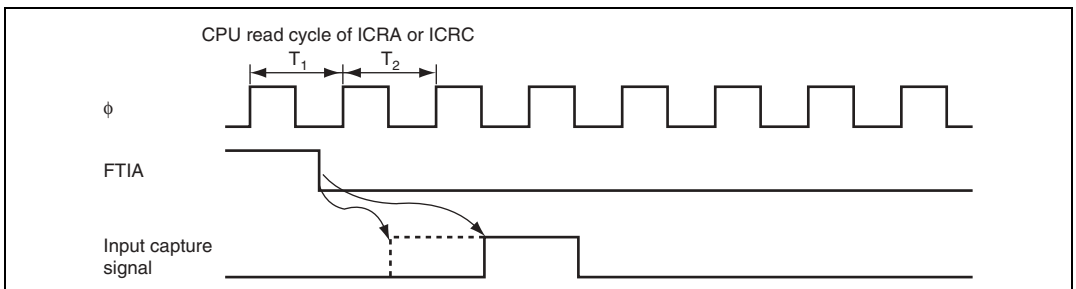

Figure 9.10 Buffered Input Capture Timing (BUFEA = 1)

9.5.6 Timing of Input Capture Flag (ICF) Setting

The input capture flag, ICFA, ICFB, ICFC, or ICFD, is set to 1 by the input capture signal. The FRC value is simultaneously transferred to the corresponding input capture register (ICRA, ICRB, ICRC, or ICRD). Figure 9.11 shows the timing of setting the ICFA to ICFD flag.

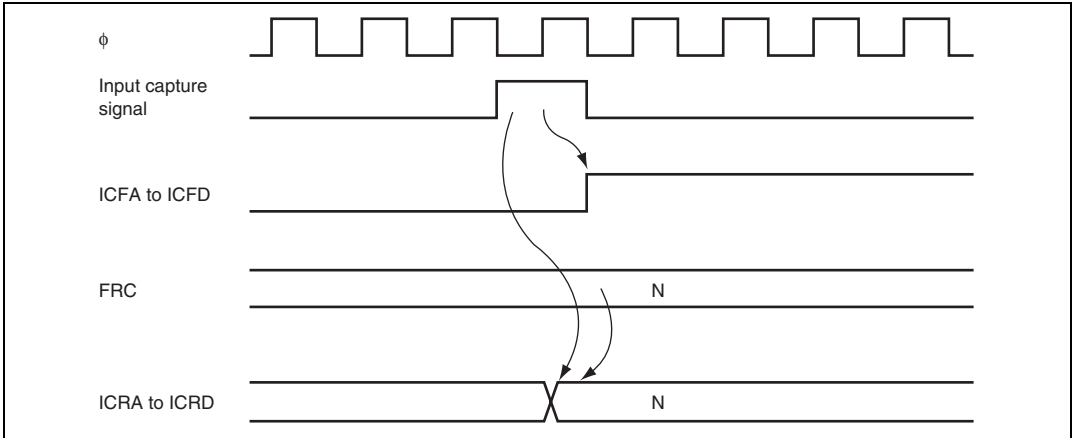

Figure 9.11 Timing of Input Capture Flag (ICFA, ICFB, ICFC, or ICFD) Setting

9.5.7 Timing of Output Compare Flag (OCF) setting

The output compare flag, OCFA or OCFB, is set to 1 by a compare-match signal generated when the FRC value matches the OCRA or OCRB value. This compare-match signal is generated at the last state in which the two values match, just before FRC increments to a new value. When the FRC and OCRA or OCRB value match, the compare-match signal is not generated until the next cycle of the clock source. Figure 9.12 shows the timing of setting the OCFA or OCFB flag.

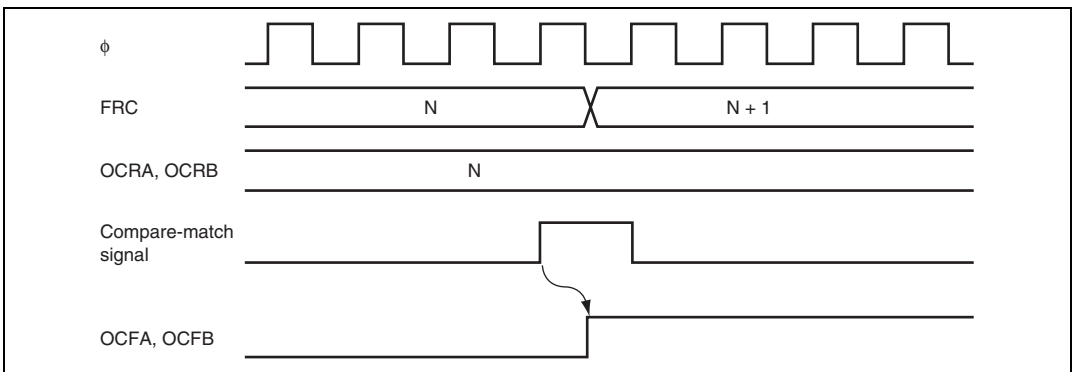

Figure 9.12 Timing of Output Compare Flag (OCFA or OCFB) Setting

9.5.8 Timing of FRC Overflow Flag Setting

The FRC overflow flag (OVF) is set to 1 when FRC overflows (changes from H'FFFF to H'0000). Figure 9.13 shows the timing of setting the OVF flag.

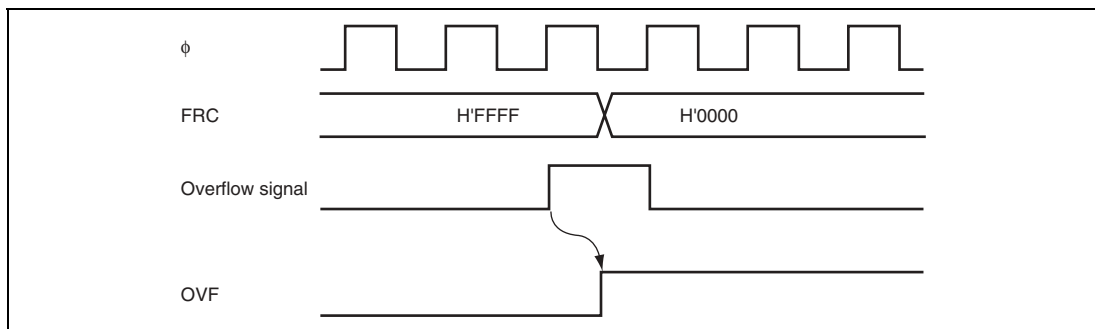

Figure 9.13 Timing of Overflow Flag (OVF) Setting

9.5.9 Automatic Addition Timing

When the OCRAMS bit in TOCR is set to 1, the contents of OCRAR and OCRAF are automatically added to OCRA alternately, and when an OCRA compare-match occurs a write to OCRA is performed. Figure 9.14 shows the OCRA write timing.

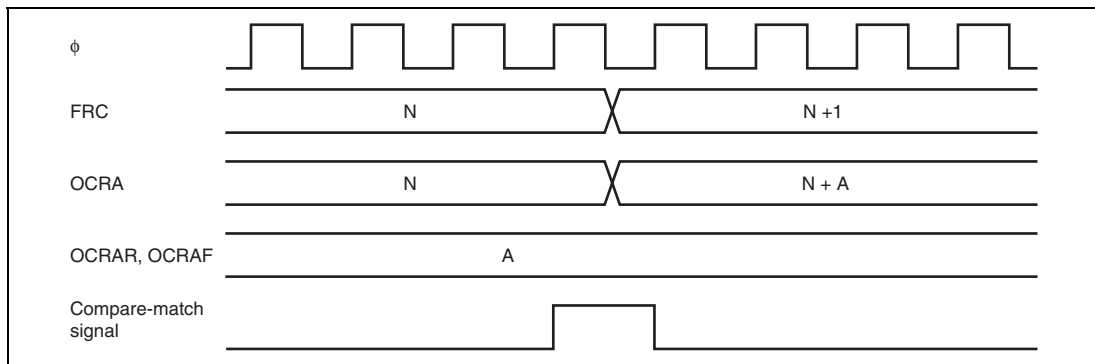

Figure 9.14 OCRA Automatic Addition Timing

9.5.10 Mask Signal Generation Timing

When the ICRDMS bit in TOCR is set to 1 and the contents of OCRDM are other than H'0000, a signal that masks the ICRD input capture signal is generated. The mask signal is set by the input capture signal. The mask signal is cleared by the sum of the ICRD contents and twice the OCRDM contents, and an FRC compare-match. Figure 9.15 shows the timing of setting the mask signal. Figure 9.16 shows the timing of clearing the mask signal.

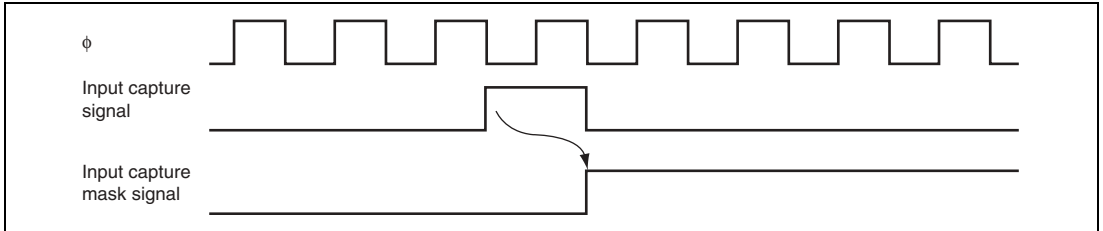

Figure 9.15 Timing of Input Capture Mask Signal Setting

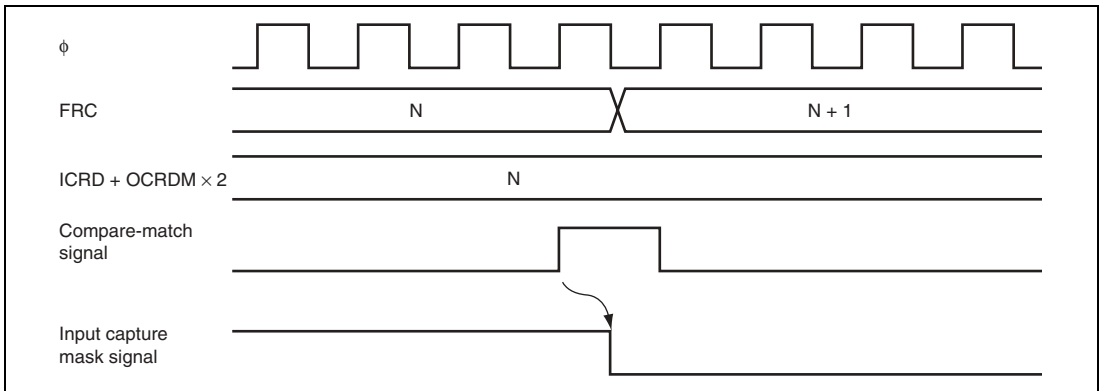

Figure 9.16 Timing of Input Capture Mask Signal Clearing

9.6 Interrupt Sources

The free-running timer can request seven interrupts: ICIA to ICID, OCIA, OCIB, and FOVI. Each interrupt can be enabled or disabled by an enable bit in TIER. Independent signals are sent to the interrupt controller for each interrupt. Table 9.2 lists the sources and priorities of these interrupts.

Table 9.2 FRT Interrupt Sources

Interrupt	Interrupt Source	Interrupt Flag	Priority
ICIA	Input capture of ICRA	ICFA	High
ICIB	Input capture of ICRB	ICFB	↑ Low
ICIC	Input capture of ICRC	ICFC	
ICID	Input capture of ICRD	ICFD	
OCIA	Compare match of OCRA	OCFA	
OCIB	Compare match of OCRB	OCFB	
FOVI	Overflow of FRC	OVF	

9.7 Usage Notes

9.7.1 Conflict between FRC Write and Clear

If an internal counter clear signal is generated during the state after an FRC write cycle, the clear signal takes priority and the write is not performed. Figure 9.17 shows the timing for this type of conflict.

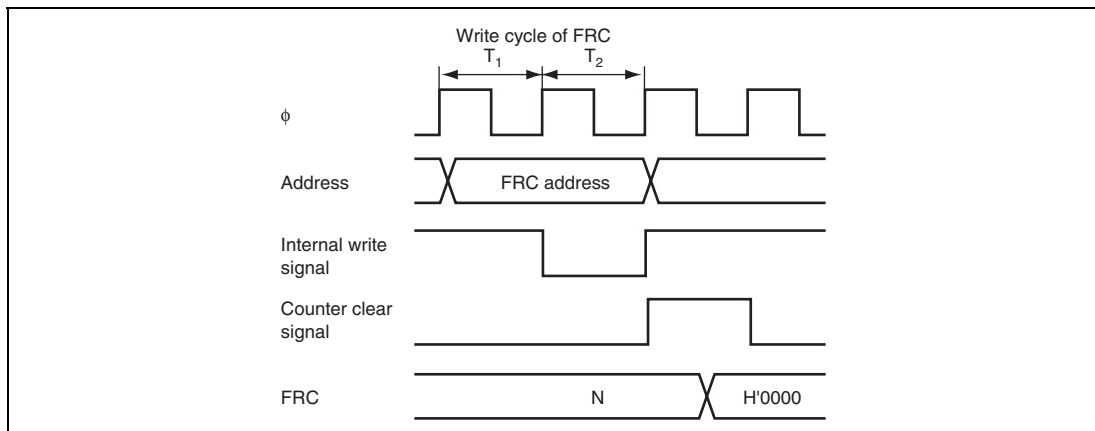

Figure 9.17 FRC Write-Clear Conflict

9.7.2 Conflict between FRC Write and Increment

If an FRC increment pulse is generated during the state after an FRC write cycle, the write takes priority and FRC is not incremented. Figure 9.18 shows the timing for this type of conflict.

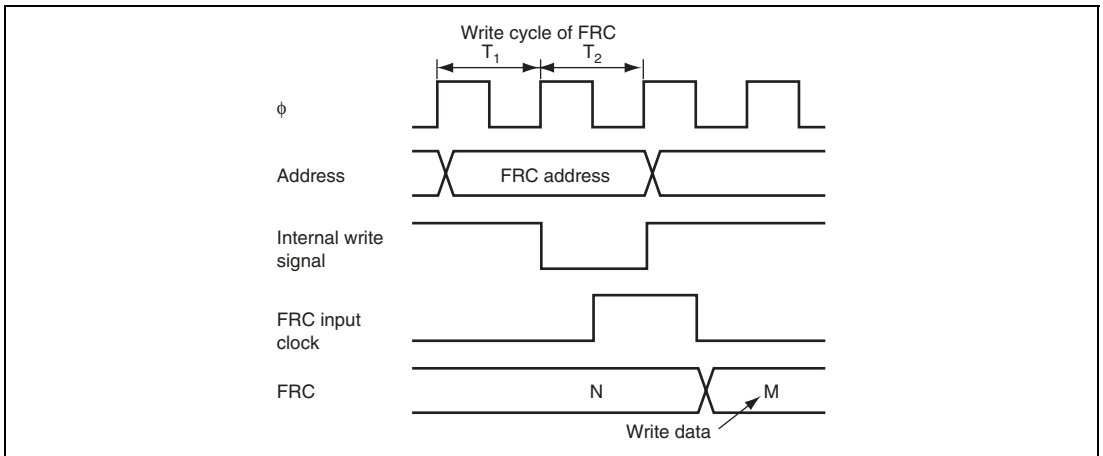
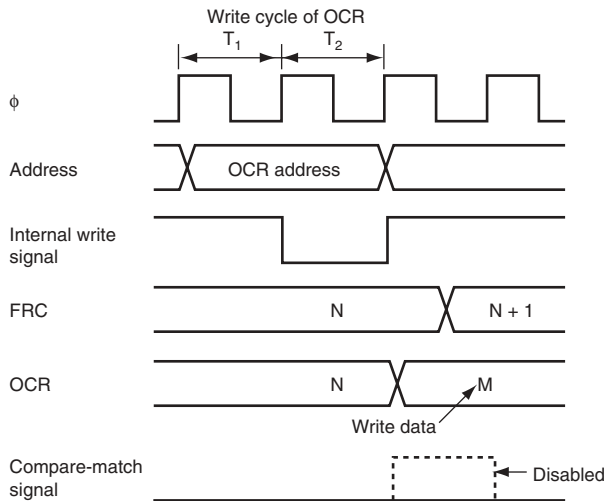

Figure 9.18 FRC Write-Increment Conflict

9.7.3 Conflict between OCR Write and Compare-Match

If a compare-match occurs during the state after an OCRA or OCRB write cycle, the write takes priority and the compare-match signal is disabled. Figure 9.19 shows the timing for this type of conflict.

If automatic addition of OCRAR and OCRAF to OCRA is selected, and a compare-match occurs in the cycle following the OCRA, OCRAR, and OCRAF write cycle, the OCRA, OCRAR and OCRAF write takes priority and the compare-match signal is disabled. Consequently, the result of the automatic addition is not written to OCRA. Figure 9.20 shows the timing for this type of conflict.



**Figure 9.19 Conflict between OCR Write and Compare-Match
(When Automatic Addition Function is Not Used)**

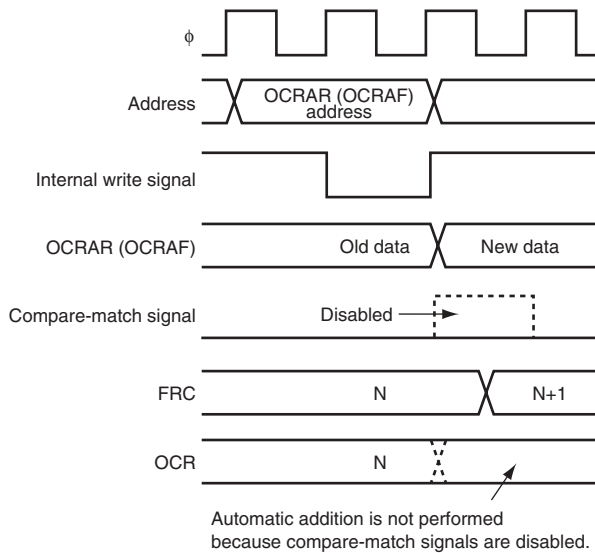

**Figure 9.20 Conflict between OCRAR/OCRAF Write and Compare-Match
(When Automatic Addition Function is Used)**

9.7.4 Switching of Internal Clock and FRC Operation

When the internal clock is changed, the changeover may cause FRC to increment. This depends on the time at which the clock is switched (bits CKS1 and CKS0 are rewritten), as shown in table 9.3.

When an internal clock is used, the FRC clock is generated on detection of the falling edge of the internal clock scaled from the system clock (ϕ). If the clock is changed when the old source is high and the new source is low, as in case no. 3 in table 9.3, the changeover is regarded as a falling edge that triggers the FRC clock, and FRC is incremented. Switching between an internal clock and external clock can also cause FRC to increment.

Table 9.3 Switching of Internal Clock and FRC Operation

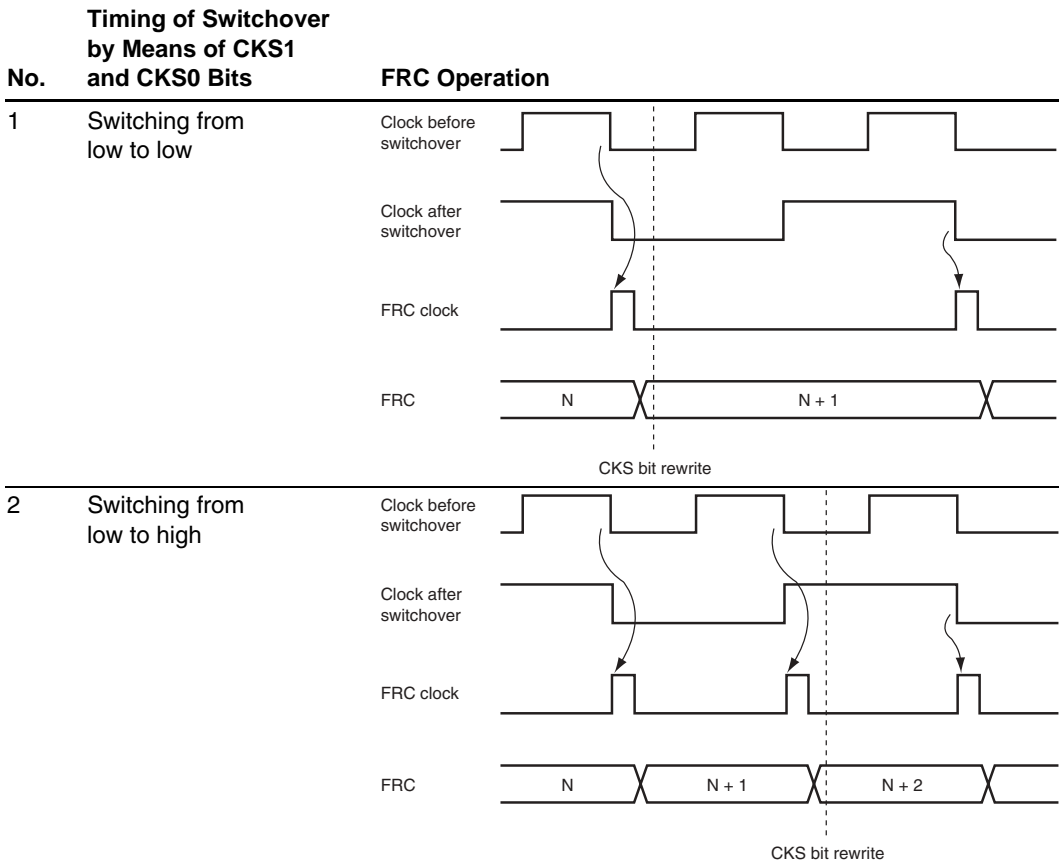

Timing of Switchover by Means of CKS1 and CKS0 Bits

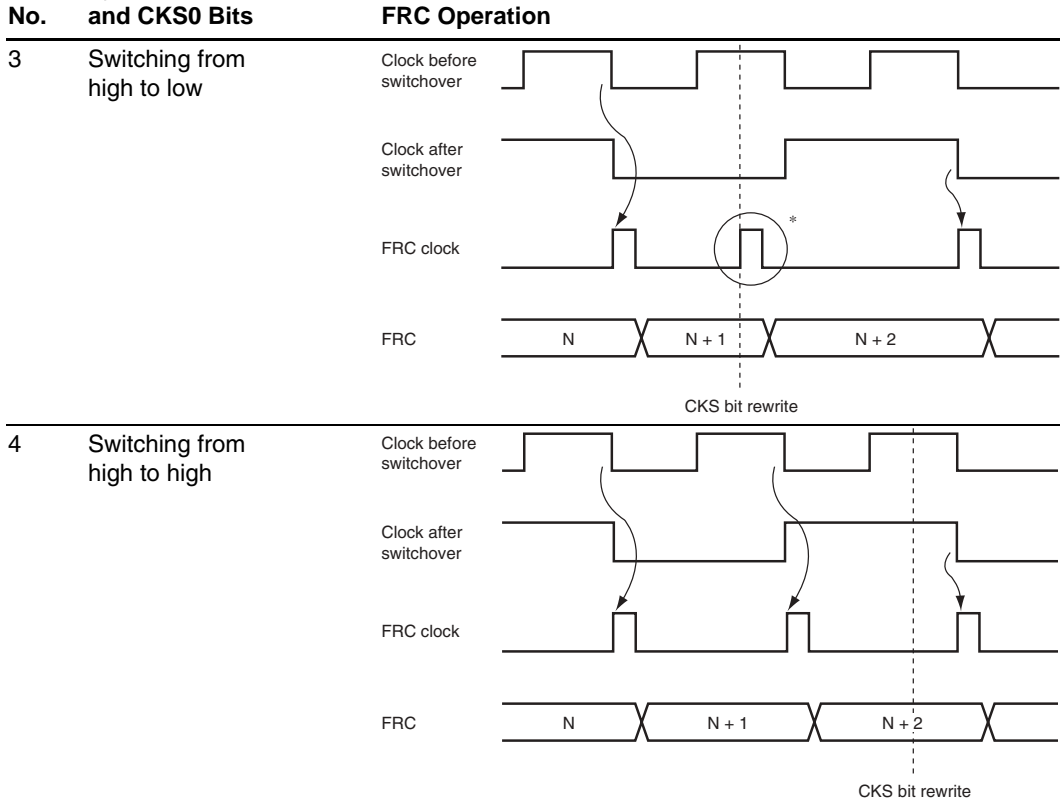

Note: * Generated on the assumption that the switchover is a falling edge; FRC is incremented.

9.7.5 Module Stop Mode Setting

FRT operation can be enabled or disabled using the module stop control register. The initial setting is for FRT operation to be halted. Register access is enabled by canceling the module stop mode. For details, refer to section 20, Power-Down Modes.

Section 10 8-Bit Timer (TMR)

This LSI has an on-chip 8-bit timer module (TMR_0, TMR_1, TMR_Y, TMR_X, TMR_B, and TMR_A) with six channels operating on the basis of an 8-bit counter. The 8-bit timer module can be used as a multifunction timer in a variety of applications, such as generation of counter reset, interrupt requests, and pulse output with an arbitrary duty cycle using a compare-match signal with two registers.

10.1 Features

Select of clock sources

The counter input clock can be six internal clocks*¹ and an external clock

Select of three ways to clear the counters

The counters can be cleared on compare-match A or compare-match B, or by an external reset signal

Timer output controlled by two compare-match signals

The timer output signal in each channel is controlled by two independent compare-match signals, enabling the timer to be used for various applications, such as the generation of pulse output or PWM output with an arbitrary duty cycle

Cascading of two channels

Cascading of TMR_0 and TMR_1, TMR_Y and TMR_X*² or TMR_B and TMR_A

Operation as a 16-bit timer can be performed using TMR_0/TMR_Y/TMR_B as the upper half and TMR_1/TMR_X/TMR_A as the lower half (16-bit count mode)

TMR_1/TMR_X/TMR_A can be used to count TMR_0/TMR_Y/TMR_B compare-match occurrences (compare-match count mode)

Multiple interrupt sources for each channels

Compare-match A: TMR_0, TMR_1, TMR_Y, TMR_B and TMR_A

Compare-match B: TMR_0, TMR_1, TMR_Y, TMR_B and TMR_A

Overflow: TMR_0, TMR_1, TMR_Y, TMR_B and TMR_A

Input capture: TMR_X and TMR_A

Input capture function (TMR_X and TMR_A)

Notes: 1. The program development tool (emulator) supports three internal clocks.

2. The program development tool (emulator) does not support this function.

Table 10.1 TMR Function

Item	TMR_0	TMR_1	TMR_Y	TMR_X	TMR_B	TMR_A
Count clock	$\phi/2$	$\phi/2$	$\phi/4$	ϕ	$\phi/4$	ϕ
	$\phi/8$	$\phi/8$	$\phi/256$	$\phi/2$	$\phi/256$	$\phi/2$
	$\phi/32$	$\phi/64$	$\phi/2048$	$\phi/4$	$\phi/2048$	$\phi/4$
	$\phi/64$	$\phi/128$	$\phi/4096^*$	$\phi/2048^*$	$\phi/4096$	$\phi/2048$
	$\phi/256$	$\phi/1024$	$\phi/8192^*$	$\phi/4096^*$	$\phi/8192$	$\phi/4096$
	$\phi/1024$	$\phi/2048$	$\phi/16384^*$	$\phi/8192^*$	$\phi/16384$	$\phi/8192$
I/O pins	TMO0	TMO1	TMOY	TMOX/ExTMOX	TMOB	TMOA
	TMCi0	TMCi1	TMIY/ExTMIY	TMIX/ExTMIX	TMiB(TMCiB/	TMiA(TMCiA/
	TMRI0	TMRI1	(TMCiY/TMRIY)	(TMCiX/TMRIX)	TMRIb)	TMRIa)
Counter clear function	Compare-match A	Compare-match A	Compare-match A	Compare-match A	Compare-match A	Compare-match A
	Compare-match B	Compare-match B	Compare-match B	Compare-match B	Compare-match B	Compare-match B
	External reset	External reset	External reset	External reset	External reset	External reset
Pulse output	O	O	O	O	O	O
Compare-match output	0 output	O	O	O	O	O
	1 output	O	O	O	O	O
	Toggle output	O	O	O	O	O
Cascaded connection		O		O*		O
16-bit count mode		O		O*		O
Compare-match count mode	—	O	—	O*	—	O
Input capture function	—	—	—	O	—	O
Interrupt source	• TCORA compare-match	• TCORA compare-match	• TCORA compare-match		• TCORA compare-match	• TCORA compare-match
	• TCORB compare-match	• TCORB compare-match	• TCORB compare-match		• TCORB compare-match	• TCORB compare-match
	• TCNT overflow	• TCNT overflow	• TCNT overflow		• TCNT overflow	• TCNT overflow
				• Input capture		• Input capture

[Legend]

O: Enable

—: Disable

Note: * The program development tool (emulator) does not support this function.

Figures 10.1 to 10.3 show block diagrams of 8-bit timers.

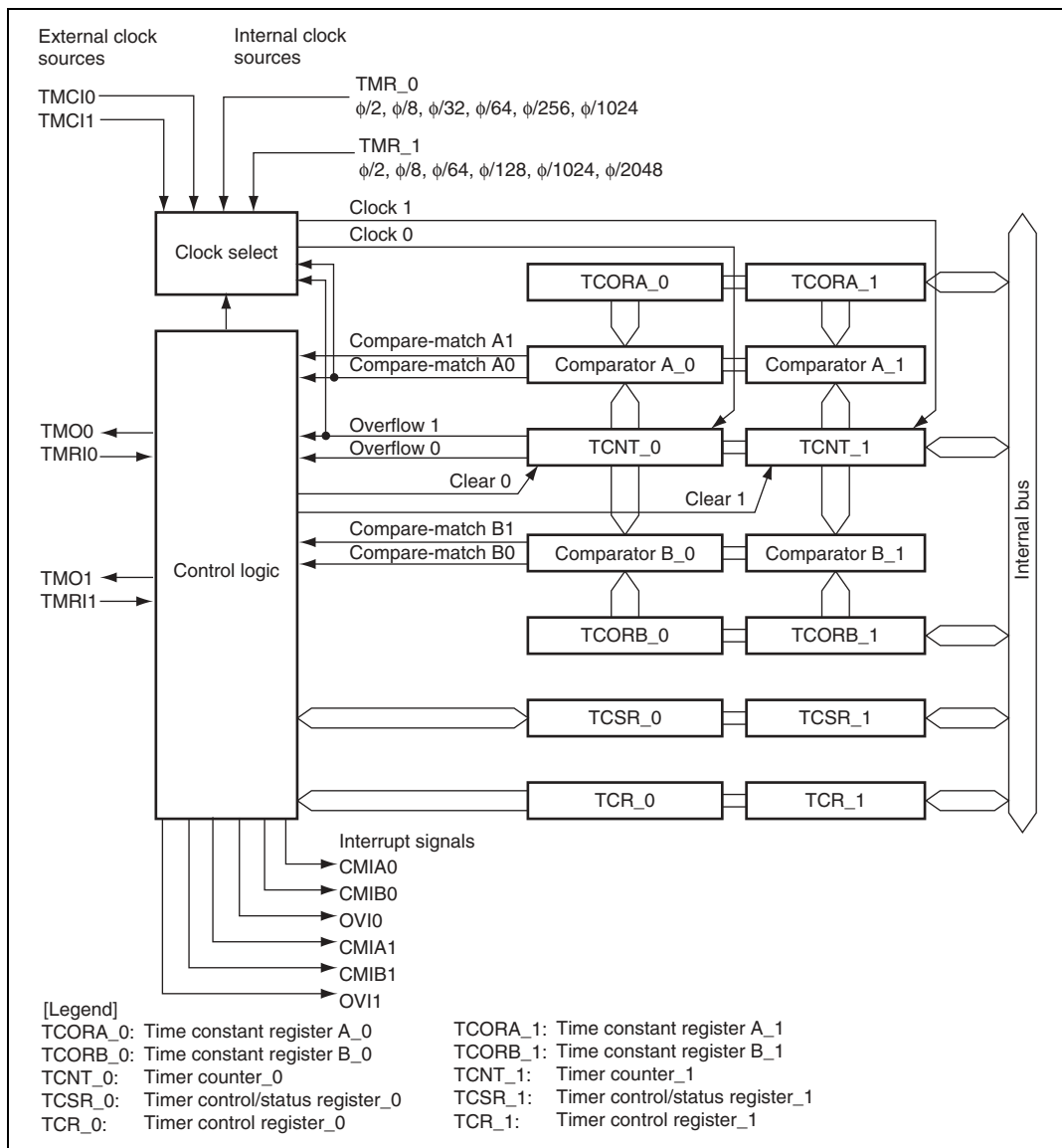

Figure 10.1 Block Diagram of 8-Bit Timer (TMR_0 and TMR_1)

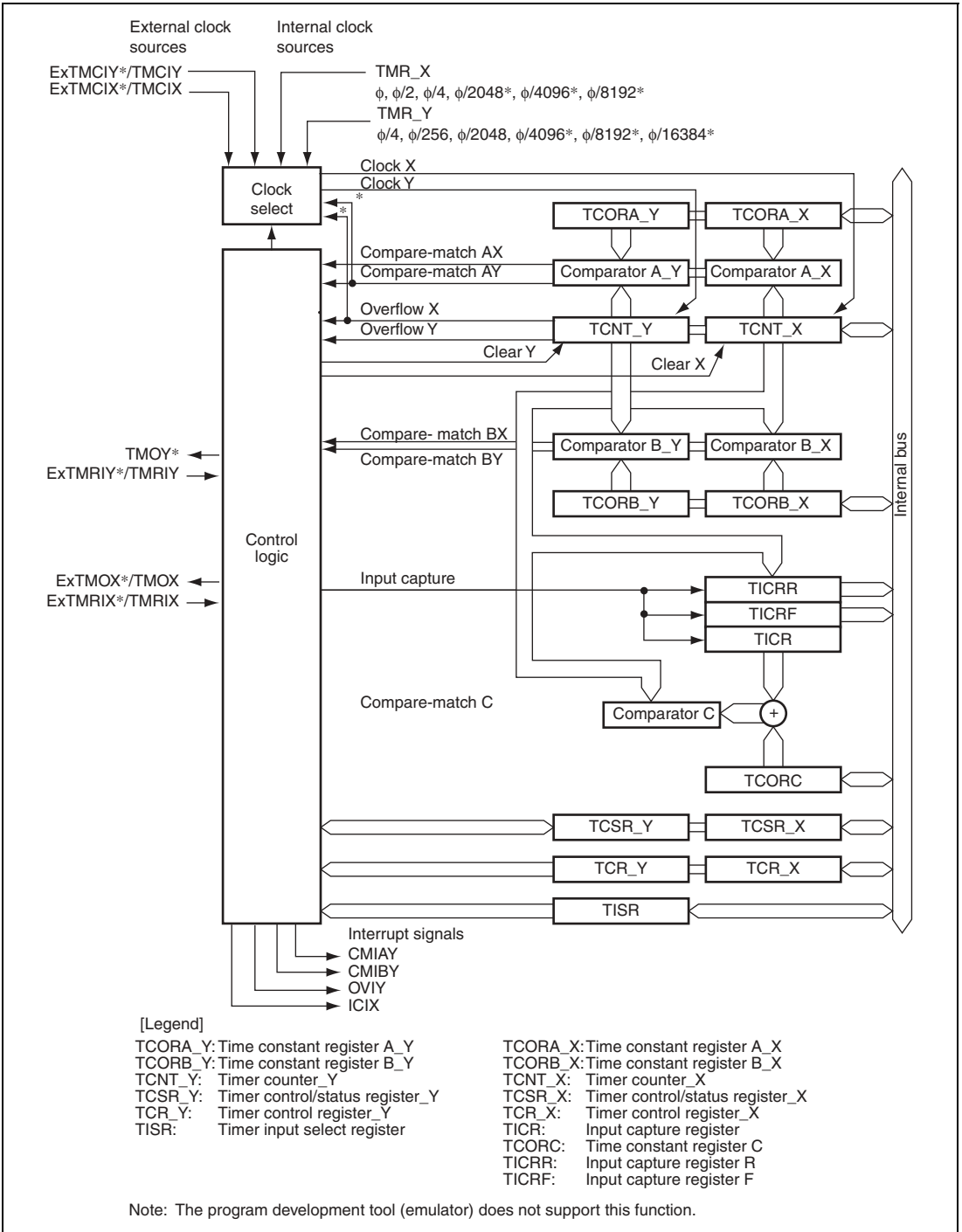
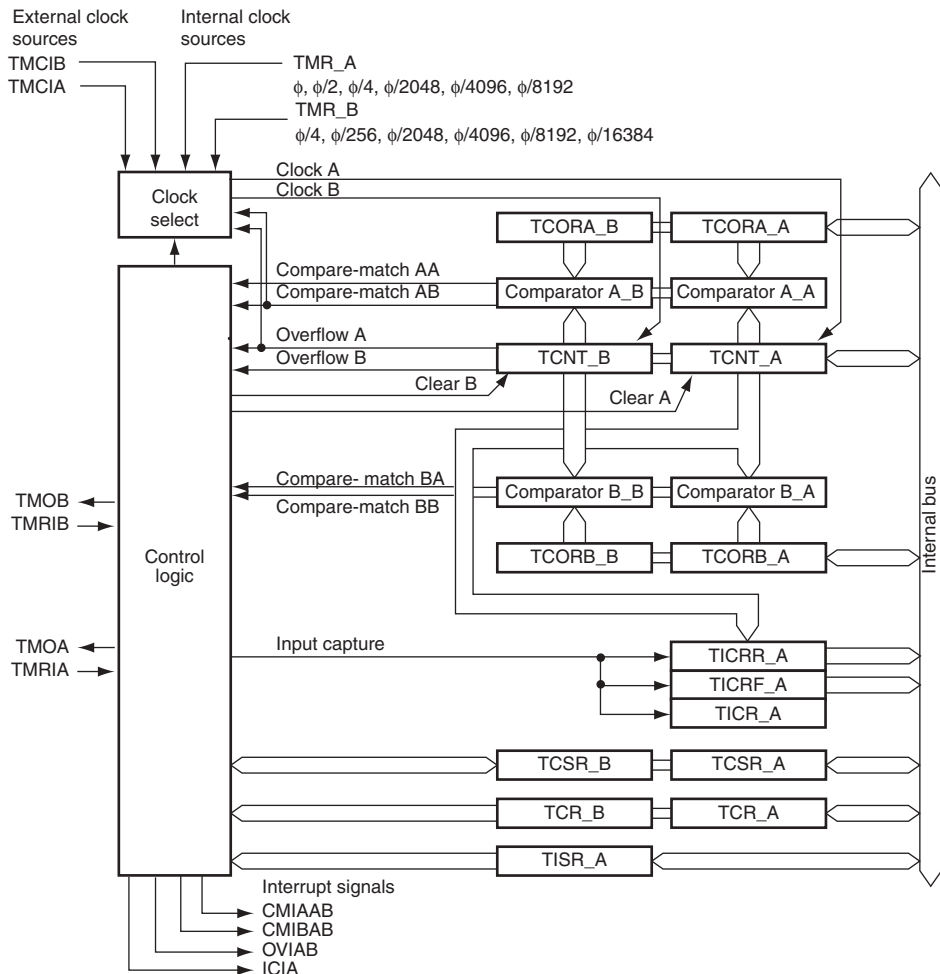

Figure 10.2 Block Diagram of 8-Bit Timer (TMR_Y and TMR_X)



[Legend]

TCORA_B: Time constant register A_B
TCORB_B: Time constant register B_B
TCNT_B: Timer counter_B
TCSR_B: Timer control/status register_B
TCR_B: Timer control register_B
TISR_B: Timer input select register_B

TCORA_A: Time constant register A_A
TCORB_A: Time constant register B_A
TCNT_A: Timer counter_A
TCSR_A: Timer control/status register_A
TCR_A: Timer control register_A
TICR_A: Input capture register_A
TICRR_A: Input capture register R_A
TICRF_A: Input capture register F_A

Figure 10.3 Block Diagram of 8-Bit Timer (TMR_B and TMR_A)

10.2 Input/Output Pins

Table 10.2 summarizes the input and output pins of the TMR.

Table 10.2 Pin Configuration

Channel	Name	Symbol	I/O	Function
TMR_0	Timer output	TMO0	Output	Output controlled by compare-match
	Timer clock input	TMCI0	Input	External clock input for the counter
	Timer reset input	TMRI0	Input	External reset input for the counter
TMR_1	Timer output	TMO1	Output	Output controlled by compare-match
	Timer clock input	TMCI1	Input	External clock input for the counter
	Timer reset input	TMRI1	Input	External reset input for the counter
TMR_Y	Timer clock/ reset input	TMIY/ExTMIY* (TMCiY/TMRiY)	Input	External clock input/ external reset input for the counter
	Timer output	TMOY*	Output	Output controlled by compare-match
TMR_X	Timer output	TMOX/ ExTMOX*	Output	Output controlled by compare-match
	Timer clock/ reset input	TMIX/ExTMIX* (TMCiX/TMRiX)	Input	External clock input/ external reset input for the counter
TMR_B	Timer clock/ reset input	TMIB (TMCiB/TMRiB)	Input	External clock input/ external reset input for the counter
	Timer output	TMOB	Output	Output controlled by compare-match
TMR_A	Timer output	TMOA	Output	Output controlled by compare-match
	Timer clock/ reset input	TMIA (TMCiA/TMRiA)	Input	External clock input/ external reset input for the counter

Note: * The program development tool (emulator) does not support this pin.

10.3 Register Descriptions

The TMR has the following registers. For details on the serial timer control register, see section 3.2.3, Serial Timer Control Register (STCR).

TMR_0

- Timer counter_0 (TCNT_0)
- Time constant register A_0 (TCORA_0)
- Time constant register B_0 (TCORB_0)
- Timer control register_0 (TCR_0)
- Timer control/status register_0 (TCSR_0)

TMR_1

- Timer counter_1 (TCNT_1)
- Time constant register A_1 (TCORA_1)
- Time constant register B_1 (TCORB_1)
- Timer control register_1 (TCR_1)
- Timer control/status register_1 (TCSR_1)

TMR_Y

- Timer counter_Y (TCNT_Y)
- Time constant register A_Y (TCORA_Y)
- Time constant register B_Y (TCORB_Y)
- Timer control register_Y (TCR_Y)
- Timer control/status register_Y (TCSR_Y)
- Timer input select register (TISR)
- Timer connection register S (TCONRS)

TMR_X

- Timer counter_X (TCNT_X)
- Time constant register A_X (TCORA_X)
- Time constant register B_X (TCORB_X)
- Timer control register_X (TCR_X)
- Timer control/status register_X (TCSR_X)
- Input capture register (TICR)
- Time constant register (TCORC)
- Input capture register R (TICRR)
- Input capture register F (TICRF)
- Timer connection register I (TCONRI)

For both TMR_Y and TMR_X

Timer XY control register (TCRXY)

TMR_B

Timer counter_B (TCNT_B)

Time constant register A_B (TCORA_B)

Time constant register B_B (TCORB_B)

Timer control register_B (TCR_B)

Timer control/status register_B (TCSR_B)

Timer input select register_B (TISR_B)

TMR_A

Timer counter_A (TCNT_A)

Time constant register A_A (TCORA_A)

Time constant register B_A (TCORB_A)

Timer control register_A (TCR_A)

Timer control/status register_A (TCSR_A)

Input capture register_A (TICR_A)

Input capture register R_A (TICRR_A)

Input capture register F_A (TICRF_A)

For both TMR_B and TMR_A

Timer AB control register (TCRAB)

- Note:
1. Some of the registers of TMR_X and TMR_Y use the same address. The registers can be switched by the TMRX/Y bit in TCONRS.
 2. The TCRXY is not supported by the program development tool (emulator).

10.3.1 Timer Counter (TCNT)

Each TCNT is an 8-bit readable/writable up-counter. TCNT_0 and TCNT_1 comprise a single 16-bit register, so they can be accessed together by word access. The clock source is selected by the CKS2 to CKS0 bits in TCR. TCNT can be cleared by an external reset input signal, compare-match A signal or compare-match B signal. The method of clearing can be selected by the CCLR1 and CCLR0 bits in TCR. When TCNT overflows (changes from H'FF to H'00), the OVF bit in TCSR is set to 1. TCNT is initialized to H'00.

TCNT_Y can be accessed when the HIE bit in SYSCR is 0 and the TMRX/Y bit in TCONRS is 1. TCNT_X can be accessed when the HIE bit in SYSCR is 0 and the TMRX/Y bit in TCONRS is 0.

10.3.2 Time Constant Register A (TCORA)

TCORA is an 8-bit readable/writable register. TCORA_0 and TCORA_1 comprise a single 16-bit register, so they can be accessed together by word access. TCORA is continually compared with the value in TCNT. When a match is detected, the corresponding compare-match flag A (CMFA) in TCSR is set to 1. Note however that comparison is disabled during the T2 state of a TCORA write cycle. The timer output from the TMO pin can be freely controlled by these compare-match A signals and the settings of output select bits OS1 and OS0 in TCSR. TCORA is initialized to H'FF.

TCORA_Y can be accessed when the HIE bit in SYSCR is 0 and the TMRX/Y bit in TCONRS is 1. TCORA_X can be accessed when the HIE bit in SYSCR is 0 and the TMRX/Y bit in TCONRS is 0.

10.3.3 Time Constant Register B (TCORB)

TCORB is an 8-bit readable/writable register. TCORB_0 and TCORB_1 comprise a single 16-bit register, so they can be accessed together by word access. TCORB is continually compared with the value in TCNT. When a match is detected, the corresponding compare-match flag B (CMFB) in TCSR is set to 1. Note however that comparison is disabled during the T2 state of a TCORB write cycle. The timer output from the TMO pin can be freely controlled by these compare-match B signals and the settings of output select bits OS3 and OS2 in TCSR. TCORB is initialized to H'FF.

TCORB_Y can be accessed when the HIE bit in SYSCR is 0 and the TMRX/Y bit in TCONRS is 1. TCORB_X can be accessed when the HIE bit in SYSCR is 0 and the TMRX/Y bit in TCONRS is 0.

10.3.4 Timer Control Register (TCR)

TCR selects the TCNT clock source and the condition by which TCNT is cleared, and enables/disables interrupt requests.

TCR_Y can be accessed when the HIE bit in SYSCR is 0 and the TMRX/Y bit in TCONRS is 1.

TCR_X can be accessed when the HIE bit in SYSCR is 0 and the TMRX/Y bit in TCONRS is 0.

Bit	Bit Name	Initial Value	R/W	Description
7	CMIEB	0	R/W	Compare-Match Interrupt Enable B Selects whether the CMFB interrupt request (CMIB) is enabled or disabled when the CMFB flag in TCSR is set to 1. For TMR_X, a CMIB interrupt does not occur irrespective of the value of this bit. 0: CMFB interrupt request (CMIB) is disabled 1: CMFB interrupt request (CMIB) is enabled
6	CMIEA	0	R/W	Compare-Match Interrupt Enable A Selects whether the CMFA interrupt request (CMIA) is enabled or disabled when the CMFA flag in TCSR is set to 1. For TMR_X, a CMIA interrupt does not occur irrespective of the value of this bit. 0: CMFA interrupt request (CMIA) is disabled 1: CMFA interrupt request (CMIA) is enabled
5	OVIE	0	R/W	Timer Overflow Interrupt Enable Selects whether the OVF interrupt request (OVI) is enabled or disabled when the OVF flag in TCSR is set to 1. For TMR_X, an OVI interrupt does not occur irrespective of the value of this bit. 0: OVF interrupt request (OVI) is disabled 1: OVF interrupt request (OVI) is enabled
4	CCLR1	0	R/W	Counter Clear 1, 0
3	CCLR0	0	R/W	These bits select the method by which the timer counter is cleared. 00: Clearing is disabled 01: Cleared on compare-match A 10: Cleared on compare-match B 11: Cleared on rising edge of external reset input
2	CKS2	0	R/W	Clock Select 2 to 0
1	CKS1	0	R/W	These bits select the clock input to TCNT and count condition, together with the ICKS1 and ICKS0 bits in STCR. For details, see table 10.3.
0	CKS0	0	R/W	

Table 10.3 Clock Input to TCNT and Count Condition (1)

Channel	TCR			STCR		Description
	CKS2	CKS1	CKS0	ICKS1	ICKS0	
TMR_0	0	0	0	—	—	Disables clock input
	0	0	1	—	0	Increments at falling edge of internal clock $\phi/8$
	0	0	1	—	1	Increments at falling edge of internal clock $\phi/2$
	0	1	0	—	0	Increments at falling edge of internal clock $\phi/64$
	0	1	0	—	1	Increments at falling edge of internal clock $\phi/32$
	0	1	1	—	0	Increments at falling edge of internal clock $\phi/1024$
	0	1	1	—	1	Increments at falling edge of internal clock $\phi/256$
	1	0	0	—	—	Increments at overflow signal from TCNT_1*
TMR_1	0	0	0	—	—	Disables clock input
	0	0	1	0	—	Increments at falling edge of internal clock $\phi/8$
	0	0	1	1	—	Increments at falling edge of internal clock $\phi/2$
	0	1	0	0	—	Increments at falling edge of internal clock $\phi/64$
	0	1	0	1	—	Increments at falling edge of internal clock $\phi/128$
	0	1	1	0	—	Increments at falling edge of internal clock $\phi/1024$
	0	1	1	1	—	Increments at falling edge of internal clock $\phi/2048$
	1	0	0	—	—	Increments at compare-match A from TCNT_0*
Common	1	0	1	—	—	Increments at rising edge of external clock
	1	1	0	—	—	Increments at falling edge of external clock
	1	1	1	—	—	Increments at both rising and falling edges of external clock

Note: * If the TMR_0 clock input is set as the TCNT_1 overflow signal and the TMR_1 clock input is set as the TCNT_0 compare-match signal simultaneously, a count-up clock cannot be generated. These settings should not be made.

Table 10.3 Clock Input to TCNT and Count Condition (2)

Channel	TCR			TCRXY* ²		Description
	CKS2	CKS1	CKS0	CKSX	CKSY	
TMR_Y	0	0	0	—	0	Disables clock input
	0	0	1	—	0	Increments at $\phi/4$
	0	1	0	—	0	Increments at $\phi/256$
	0	1	1	—	0	Increments at $\phi/2048$
	1	0	0	—	0	Disables clock input
	0	0	0	—	1	Disables clock input
	0	0	1	—	1	Increments at $\phi/4096$
	0	1	0	—	1	Increments at $\phi/8192$
	0	1	1	—	1	Increments at $\phi/16384$
	1	0	0	—	1	Increments at overflow signal from TCNT_X* ¹
	1	0	1	—	—	Increments at rising edge of external clock
	1	1	0	—	—	Increments at falling edge of external clock
1	1	1	—	—	Increments at both rising and falling edges of external clock	
TMR_X	0	0	0	0	—	Disables clock input
	0	0	1	0	—	Increments at ϕ
	0	1	0	0	—	Increments at $\phi/2$
	0	1	1	0	—	Increments at $\phi/4$
	1	0	0	0	—	Disables clock input
	0	0	0	1	—	Disables clock input
	0	0	1	1	—	Increments at $\phi/2048$
	0	1	0	1	—	Increments at $\phi/4096$
	0	1	1	1	—	Increments at $\phi/8192$
	1	0	0	1	—	Increments at compare-match A from TCNT_Y* ¹
	1	0	1	—	—	Increments at rising edge of external clock
	1	1	0	—	—	Increments at falling edge of external clock
1	1	1	—	—	Increments at both rising and falling edges of external clock	

Notes: 1. If the TMR_Y clock input is set as the TCNT_X overflow signal and the TMR_X clock input is set as the TCNT_Y compare-match signal simultaneously, a count-up clock cannot be generated. These settings should not be made.

2. The program development tool (emulator) does not support TCRXY. Selection of the internal clock is only available when CKSX = 0 and CKSY = 0.

Table 10.3 Clock Input to TCNT and Count Condition (3)

Channel	TCR			TCRAB		Description
	CKS2	CKS1	CKS0	CKSA	CKSB	
TMR_B	0	0	0	—	0	Disables clock input
	0	0	1	—	0	Increments at $\phi/4$
	0	1	0	—	0	Increments at $\phi/256$
	0	1	1	—	0	Increments at $\phi/2048$
	1	0	0	—	0	Disables clock input
	0	0	0	—	1	Disables clock input
	0	0	1	—	1	Increments at $\phi/4096$
	0	1	0	—	1	Increments at $\phi/8192$
	0	1	1	—	1	Increments at $\phi/16384$
	1	0	0	—	1	Increments at overflow signal from TCNT_A*
	1	0	1	—	—	Increments at rising edge of external clock
	1	1	0	—	—	Increments at falling edge of external clock
TMR_A	0	0	0	0	—	Disables clock input
	0	0	1	0	—	Increments at ϕ
	0	1	0	0	—	Increments at $\phi/2$
	0	1	1	0	—	Increments at $\phi/4$
	1	0	0	0	—	Disables clock input
	0	0	0	1	—	Disables clock input
	0	0	1	1	—	Increments at $\phi/2048$
	0	1	0	1	—	Increments at $\phi/4096$
	0	1	1	1	—	Increments at $\phi/8192$
	1	0	0	1	—	Increments at compare-match A from TCNT_B*
	1	0	1	—	—	Increments at rising edge of external clock
	1	1	0	—	—	Increments at falling edge of external clock
1	1	1	—	—	Increments at both rising and falling edges of external clock	

Notes: * If the TMR_B clock input is set as the TCNT_A overflow signal and the TMR_A clock input is set as the TCNT_B compare-match signal simultaneously, a count-up clock cannot be generated. These settings should not be made.

10.3.5 Timer Control/Status Register (TCSR)

TCSR indicates the status flags and controls compare-match output.

TCSR_0

Bit	Bit Name	Initial Value	R/W	Description
7	CMFB	0	R/(W)*	Compare-Match Flag B [Setting condition] When the values of TCNT_0 and TCORB_0 match [Clearing condition] Read CMFB when CMFB = 1, then write 0 in CMFB
6	CMFA	0	R/(W)*	Compare-Match Flag A [Setting condition] When the values of TCNT_0 and TCORA_0 match [Clearing condition] Read CMFA when CMFA = 1, then write 0 in CMFA
5	OVF	0	R/(W)*	Timer Overflow Flag [Setting condition] When TCNT_0 overflows from H'FF to H'00 [Clearing condition] Read OVF when OVF = 1, then write 0 in OVF
4	ADTE	0	R/W	A/D Trigger Enable Enables or disables A/D converter start requests by compare-match A. 0: A/D converter start requests by compare-match A are disabled 1: A/D converter start requests by compare-match A are enabled
3	OS3	0	R/W	Output Select 3, 2
2	OS2	0	R/W	These bits specify how the TMO0 pin output level is to be changed by compare-match B of TCORB_0 and TCNT_0. 00: No change 01: 0 is output 10: 1 is output 11: Output is inverted (toggle output)
1	OS1	0	R/W	Output Select 1, 0
0	OS0	0	R/W	These bits specify how the TMO0 pin output level is to be changed by compare-match A of TCORA_0 and TCNT_0. 00: No change 01: 0 is output 10: 1 is output 11: Output is inverted (toggle output)

Note: * Only 0 can be written, for flag clearing.

TCSR_1

Bit	Bit Name	Initial Value	R/W	Description
7	CMFB	0	R/(W)*	Compare-Match Flag B [Setting condition] When the values of TCNT_1 and TCORB_1 match [Clearing condition] Read CMFB when CMFB = 1, then write 0 in CMFB
6	CMFA	0	R/(W)*	Compare-Match Flag A [Setting condition] When the values of TCNT_1 and TCORA_1 match [Clearing condition] Read CMFA when CMFA = 1, then write 0 in CMFA
5	OVF	0	R/(W)*	Timer Overflow Flag [Setting condition] When TCNT_1 overflows from H'FF to H'00 [Clearing condition] Read OVF when OVF = 1, then write 0 in OVF
4	—	1	R	Reserved This bit is always read as 1 and cannot be modified.
3	OS3	0	R/W	Output Select 3, 2
2	OS2	0	R/W	These bits specify how the TMO1 pin output level is to be changed by compare-match B of TCORB_1 and TCNT_1. 00: No change 01: 0 is output 10: 1 is output 11: Output is inverted (toggle output)
1	OS1	0	R/W	Output Select 1, 0
0	OS0	0	R/W	These bits specify how the TMO1 pin output level is to be changed by compare-match A of TCORA_1 and TCNT_1. 00: No change 01: 0 is output 10: 1 is output 11: Output is inverted (toggle output)

Note: * Only 0 can be written, for flag clearing.

TCSR_Y

Bit	Bit Name	Initial Value	R/W	Description
7	CMFB	0	R/(W)* ¹	Compare-Match Flag B [Setting condition] When the values of TCNT_Y and TCORB_Y match [Clearing condition] Read CMFB when CMFB = 1, then write 0 in CMFB
6	CMFA	0	R/(W)* ¹	Compare-Match Flag A [Setting condition] When the values of TCNT_Y and TCORA_Y match [Clearing condition] Read CMFA when CMFA = 1, then write 0 in CMFA
5	OVF	0	R/(W)* ¹	Timer Overflow Flag [Setting condition] When TCNT_Y overflows from H'FF to H'00 [Clearing condition] Read OVF when OVF = 1, then write 0 in OVF
4	ICIE	0	R/W	Input Capture Interrupt Enable Enables or disables the ICF interrupt request (ICIX) when the ICF bit in TCSR_X is set to 1. 0: ICF interrupt request (ICIX) is disabled 1: ICF interrupt request (ICIX) is enabled
3	OS3	0	R/W	Output Select 3, 2
2	OS2	0	R/W	These bits specify how the TMOY pin* ² output level is to be changed by compare-match B of TCORB_Y and TCNT_Y. 00: No change 01: 0 is output 10: 1 is output 11: Output is inverted (toggle output)
1	OS1	0	R/W	Output Select 1, 0
0	OS0	0	R/W	These bits specify how the TMOY pin* ² output level is to be changed by compare-match A of TCORA_Y and TCNT_Y. 00: No change 01: 0 is output 10: 1 is output 11: Output is inverted (toggle output)

Notes: 1. Only 0 can be written, for flag clearing.

2. The program development tool (emulator) does not support this pin.

TCSR_X

Bit	Bit Name	Initial Value	R/W	Description
7	CMFB	0	R/(W)*	Compare-Match Flag B [Setting condition] When the values of TCNT_X and TCORB_X match [Clearing condition] Read CMFB when CMFB = 1, then write 0 in CMFB
6	CMFA	0	R/(W)*	Compare-Match Flag A [Setting condition] When the values of TCNT_X and TCORA_X match [Clearing condition] Read CMFA when CMFA = 1, then write 0 in CMFA
5	OVF	0	R/(W)*	Timer Overflow Flag [Setting condition] When TCNT_X overflows from H'FF to H'00 [Clearing condition] Read OVF when OVF = 1, then write 0 in OVF
4	ICF	0	R/(W)*	Input Capture Flag [Setting condition] When a rising edge and falling edge is detected in the external reset signal in that order. [Clearing condition] Read ICF when ICF = 1, then write 0 in ICF
3	OS3	0	R/W	Output Select 3, 2
2	OS2	0	R/W	These bits specify how the TMOX pin output level is to be changed by compare-match B of TCORB_X and TCNT_X. 00: No change 01: 0 is output 10: 1 is output 11: Output is inverted (toggle output)
1	OS1	0	R/W	Output Select 1, 0
0	OS0	0	R/W	These bits specify how the TMOX pin output level is to be changed by compare-match A of TCORA_X and TCNT_X. 00: No change 01: 0 is output 10: 1 is output 11: Output is inverted (toggle output)

Note: * Only 0 can be written, for flag clearing.

TCSR_B

Bit	Bit Name	Initial Value	R/W	Description
7	CMFB	0	R/(W)*	Compare-Match Flag B [Setting condition] When the values of TCNT_B and TCORB_B match [Clearing condition] Read CMFB when CMFB = 1, then write 0 in CMFB
6	CMFA	0	R/(W)*	Compare-Match Flag A [Setting condition] When the values of TCNT_B and TCORA_B match [Clearing condition] Read CMFA when CMFA = 1, then write 0 in CMFA
5	OVF	0	R/(W)*	Timer Overflow Flag [Setting condition] When TCNT_B overflows from H'FF to H'00 [Clearing condition] Read OVF when OVF = 1, then write 0 in OVF
4	ICIE	0	R/W	Input Capture Interrupt Enable Enables or disables the ICF interrupt request (ICIA) when the ICF bit in TCSR_A is set to 1. 0: ICF interrupt request (ICIA) is disabled 1: ICF interrupt request (ICIA) is enabled
3	OS3	0	R/W	Output Select 3, 2
2	OS2	0	R/W	These bits specify how the TMOB pin output level is to be changed by compare-match B of TCORB_B and TCNT_B. 00: No change 01: 0 is output 10: 1 is output 11: Output is inverted (toggle output)
1	OS1	0	R/W	Output Select 1, 0
0	OS0	0	R/W	These bits specify how the TMOB pin output level is to be changed by compare-match A of TCORA_B and TCNT_B. 00: No change 01: 0 is output 10: 1 is output 11: Output is inverted (toggle output)

Notes: * Only 0 can be written, for flag clearing.

TCSR_A

Bit	Bit Name	Initial Value	R/W	Description
7	CMFB	0	R/(W)*	Compare-Match Flag B [Setting condition] When the values of TCNT_A and TCORB_A match [Clearing condition] Read CMFB when CMFB = 1, then write 0 in CMFB
6	CMFA	0	R/(W)*	Compare-Match Flag A [Setting condition] When the values of TCNT_A and TCORA_A match [Clearing condition] Read CMFA when CMFA = 1, then write 0 in CMFA
5	OVF	0	R/(W)*	Timer Overflow Flag [Setting condition] When TCNT_A overflows from H'FF to H'00 [Clearing condition] Read OVF when OVF = 1, then write 0 in OVF
4	ICF	0	R/(W)*	Input Capture Flag [Setting condition] When a rising edge and falling edge is detected in the external reset signal in that order. [Clearing condition] Read ICF when ICF = 1, then write 0 in ICF
3	OS3	0	R/W	Output Select 3, 2
2	OS2	0	R/W	These bits specify how the TMOA pin output level is to be changed by compare-match B of TCORB_A and TCNT_A. 00: No change 01: 0 is output 10: 1 is output 11: Output is inverted (toggle output)
1	OS1	0	R/W	Output Select 1, 0
0	OS0	0	R/W	These bits specify how the TMOA pin output level is to be changed by compare-match A of TCORA_A and TCNT_A. 00: No change 01: 0 is output 10: 1 is output 11: Output is inverted (toggle output)

Note: * Only 0 can be written, for flag clearing.

10.3.6 Time Constant Register (TCORC)

TCORC is an 8-bit readable/writable register. The sum of contents of TCORC and TICR is always compared with TCNT. When a match is detected, a compare-match C signal is generated. However, comparison at the T2 state in the write cycle to TCORC and at the input capture cycle of TICR is disabled. TCORC is initialized to H'FF.

10.3.7 Input Capture Registers R and F (TICRR, TICRF, TICRR_A and TICRF_A)

TICRR and TICRF are 8-bit read-only registers. While the ICST bit in TCONRI (TCRAB) is set to 1, the contents of TCNT are transferred at the rising edge and falling edge of the external reset input (TMRIX and TMRIA) in that order. The ICST bit is cleared to 0 when one capture operation ends. TICRR and TICRF are initialized to H'00.

10.3.8 Timer Input Select Register (TISR and TISR_B)

TISR permits or prohibits a signal source of external clock/reset input for the counter.

Bit	Bit Name	Initial Value	R/W	Description
7 to 1	—	All 1	R/(W)	Reserved The initial value should not be changed.
0	IS	0	R/W	Input Select Selects a timer clock/reset input pin (TMIn) as the signal source of external clock/reset input for the TMR_n counter. 0: TMIn (TMCIn/TMRIn) is prohibited 1: TMIn (TMCIn/TMRIn) is permitted for input

Note: n = Y and B

10.3.9 Timer Connection Register I (TCONRI)

TCONRI controls the input capture function.

Bit	Bit Name	Initial Value	R/W	Description
7 to 5	—	All 0	R/W	Reserved The initial value should not be changed.
4	ICST	0	R/W	Input Capture Start Bit TMR_X has input capture registers (TICRR and TICRF). TICRR and TICRF can measure the width of a pulse by means of a single capture operation under the control of the ICST bit. When a rising edge followed by a falling edge is detected on TMRIX after the ICST bit is set to 1, the contents of TCNT at those points are captured into TICRR and TICRF, respectively, and the ICST bit is cleared to 0. [Clearing condition] When a rising edge followed by a falling edge is detected on TMRIX [Setting condition] When 1 is written in ICST after reading ICST = 0
3 to 0	—	All 0	R/W	Reserved The initial values should not be modified.

10.3.10 Timer Connection Register S (TCONRS)

TCONRS selects whether to access TMR_X or TMR_Y registers.

Bit	Bit Name	Initial Value	R/W	Description
7	TMR_X/Y	0	R/W	TMR_X/TMR_Y Access Select For details, see table 10.4. 0: The TMR_X registers are accessed at addresses H'(FF)FFF0 to H'(FF)FFF5 1: The TMR_Y registers are accessed at addresses H'(FF)FFF0 to H'(FF)FFF5
6 to 0	—	All 0	R/W	Reserved The initial values should not be modified.

Table 10.4 Registers Accessible by TMR_X/TMR_Y

TMRX/Y	H'FFF0	H'FFF1	H'FFF2	H'FFF3	H'FFF4	H'FFF5	H'FFF6	H'FFF7
0	TMR_X	TMR_X	TMR_X	TMR_X	TMR_X	TMR_X	TMR_X	TMR_X
	TCR_X	TCSR_X	TICRR	TICRF	TCNT	TCORC	TCORA_X	TCORB_X
1	TMR_Y	TMR_Y	TMR_Y	TMR_Y	TMR_Y	TMR_Y		
	TCR_Y	TCSR_Y	TCORA_Y	TCORB_Y	TCNT_Y	TISR		

10.3.11 Timer XY Control Register (TCRXY)

TCRXY selects the TMR_X and TMR_Y output pins and internal clock.

Bit	Bit Name	Initial Value	R/W	Description
7	IOSX	0	R/W	TMR_X I/O Select 0: Output to P67/TMOX and input from P60/TMIX 1: Output to PF6/ExTMOX and input from PF4/ExTMIX
6	IOSY	0	R/W	TMR_Y Output Enable 0: Output to PF7/TMOY is prohibited and input from P62/TMIY 1: Output to PF7/TMOY is permitted and input from PF5/ExTMIY
5	CKSX	0	R/W	TMR_X Clock Select For details about selection, see the clock conditions in table 10.3.
4	CKSY	0	R/W	TMR_Y Clock Select For details about selection, see the clock conditions in table 10.3.
3 to 0	—	All 0	R/W	Reserved The initial value should not be changed.

Note: * The program development tool (emulator) does not support TCRXY.

10.3.12 Timer AB Control Register (TCRAB)

TCRAB selects the internal clock or controls the input capture function in the TMR_A and TMR_B.

Bit	Bit Name	Initial Value	R/W	Description
7, 6	—	All 0	R/W	Reserved The initial value should not be modified.
5	CKSA	0	R/W	TMR_A Clock Select For details about selection, see the clock conditions in table 10.3.
4	CKSB	0	R/W	TMR_B Clock Select For details about selection, see the clock conditions in table 10.3.
3	ICST	0	R/W	Input Capture Start Bit TMR_A has input capture registers (TICRR_A and TICRF_A). TICRR and TICRF can measure the width of a pulse by means of a single capture operation under the control of the ICST bit. When a rising edge followed by a falling edge is detected on TMR_A after the ICST bit is set to 1, the contents of TCNT at those points are captured into TICRR and TICRF, respectively, and the ICST bit is cleared to 0. [Clearing condition] When a rising edge followed by a falling edge is detected on TMR_A [Setting condition] When 1 is written in ICST after reading ICST = 0
2 to 0	—	0	R/W	Reserved The initial value should not be modified.

Note: * The program development tool (emulator) does not support TCRXY.

10.4 Operation

10.4.1 Pulse Output

Figure 10.4 shows an example for outputting an arbitrary duty pulse.

1. Clear the CCLR1 bit in TCR to 0 so that TCNT is cleared according to the compare match of TCORA, and then set the CCLR0 bit to 1.
2. Set the OS3 to OS0 bits in TCSR to B'0110 so that 1 is output according to the compare match of TCORA and 0 is output according to the compare match of TCORB.

According to the above settings, the waveforms with the TCORA cycle and TCORB pulse width can be output without the intervention of software.

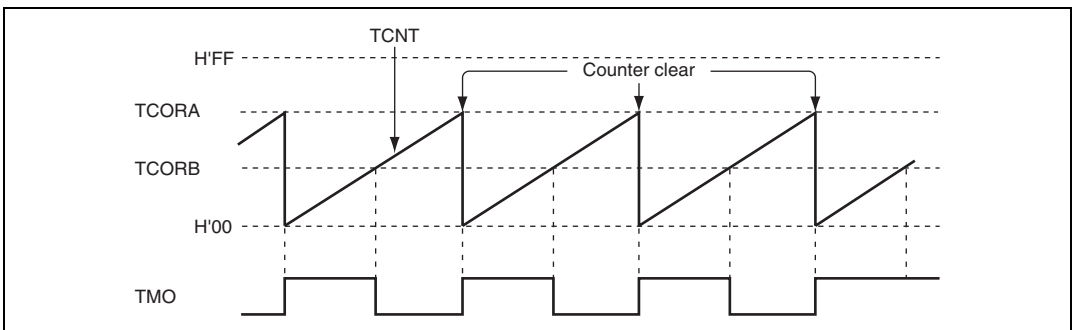

Figure 10.4 Pulse Output Example

10.5 Operation Timing

10.5.1 TCNT Count Timing

Figure 10.5 shows the TCNT count timing with an internal clock source. Figure 10.6 shows the TCNT count timing with an external clock source. The pulse width of the external clock signal must be at least 1.5 system clocks (ϕ) for a single edge and at least 2.5 system clocks (ϕ) for both edges. The counter will not increment correctly if the pulse width is less than these values.

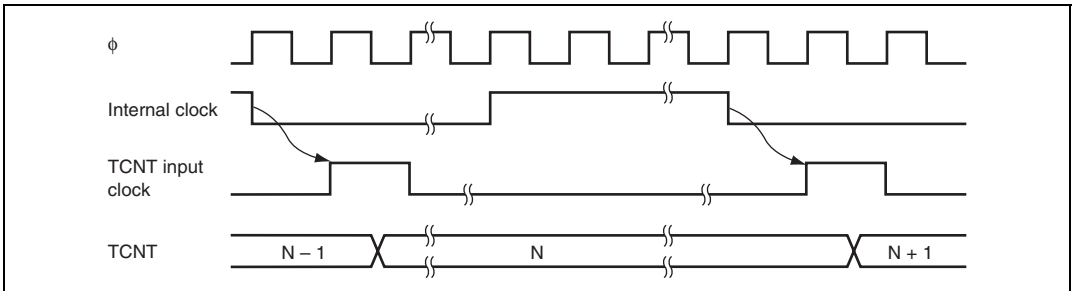

Figure 10.5 Count Timing for Internal Clock Input

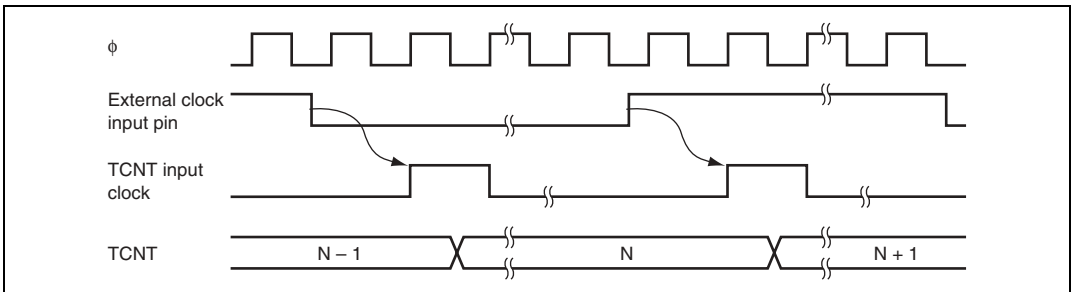

Figure 10.6 Count Timing for External Clock Input (Both Edges)

10.5.2 Timing of CMFA and CMFB Setting at Compare-Match

The CMFA and CMFB flags in TCSR are set to 1 by a compare-match signal generated when the TCNT and TCOR values match. The compare-match signal is generated at the last state in which the match is true, just when the timer counter is updated. Therefore, when TCNT and TCOR match, the compare-match signal is not generated until the next TCNT input clock. Figure 10.7 shows the timing of CMF flag setting.

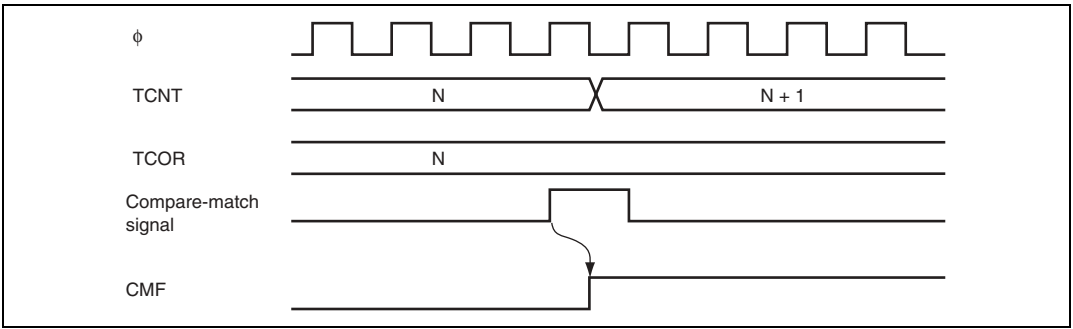

Figure 10.7 Timing of CMF Setting at Compare-Match

10.5.3 Timing of Timer Output at Compare-Match

When a compare-match signal occurs, the timer output changes as specified by the OS3 to OS0 bits in TCSR. Figure 10.8 shows the timing of timer output when the output is set to toggle by a compare-match A signal.

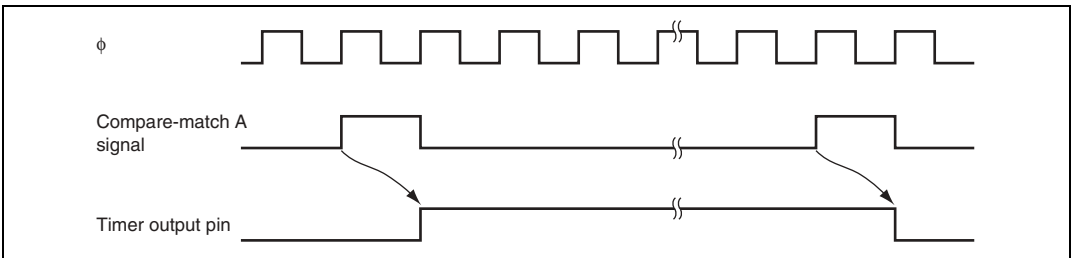

Figure 10.8 Timing of Toggled Timer Output by Compare-Match A Signal

10.5.4 Timing of Counter Clear at Compare-Match

TCNT is cleared when compare-match A or compare-match B occurs, depending on the setting of the CCLR1 and CCLR0 bits in TCR. Figure 10.9 shows the timing of clearing the counter by a compare-match.

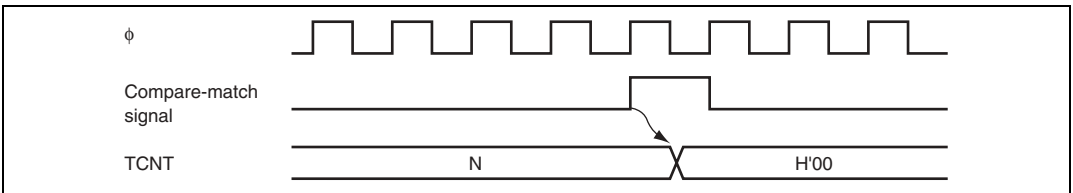

Figure 10.9 Timing of Counter Clear by Compare-Match

10.5.5 TCNT External Reset Timing

TCNT is cleared at the rising edge of an external reset input, depending on the settings of the CCLR1 and CCLR0 bits in TCR. The width of the clearing pulse must be at least 1.5 states. Figure 10.10 shows the timing of clearing the counter by an external reset input.

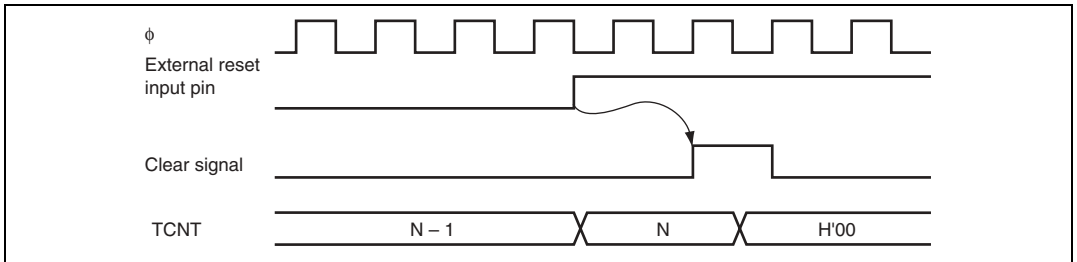

Figure 10.10 Timing of Counter Clear by External Reset Input

10.5.6 Timing of Overflow Flag (OVF) Setting

The OVF bit in TCSR is set to 1 when the TCNT overflows (changes from $H'FF$ to $H'00$). Figure 10.11 shows the timing of OVF flag setting.

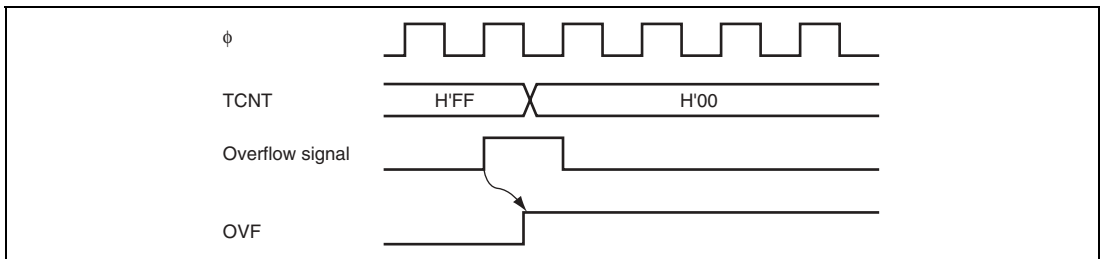

Figure 10.11 Timing of OVF Flag Setting

10.6 TMR_0 and TMR_1 Cascaded Connection

If bits CKS2 to CKS0 in either TCR_0 or TCR_1 are set to B'100, the 8-bit timers of the two channels are cascaded. With this configuration, the 16-bit count mode or compare-match count mode is available.

10.6.1 16-Bit Count Mode

When bits CKS2 to CKS0 in TCR_0 are set to B'100, the timer functions as a single 16-bit timer with TMR_0 occupying the upper 8 bits and TMR_1 occupying the lower 8 bits.

Setting of compare-match flags

The CMF flag in TCSR_0 is set to 1 when a 16-bit compare-match occurs.

The CMF flag in TCSR_1 is set to 1 when a lower 8-bit compare-match occurs.

Counter clear specification

If the CCLR1 and CCLR0 bits in TCR_0 have been set for counter clear at compare-match, the 16-bit counter (TCNT_0 and TCNT_1 together) is cleared when a 16-bit compare-match occurs. The 16-bit counter (TCNT_0 and TCNT_1 together) is also cleared when counter clear by the TMI0 pin has been set.

The settings of the CCLR1 and CCLR0 bits in TCR_1 are ignored. The lower 8 bits cannot be cleared independently.

Pin output

Control of output from the TMO0 pin by bits OS3 to OS0 in TCSR_0 is in accordance with the 16-bit compare-match conditions.

Control of output from the TMO1 pin by bits OS3 to OS0 in TCSR_1 is in accordance with the lower 8-bit compare-match conditions.

10.6.2 Compare-Match Count Mode

When bits CKS2 to CKS0 in TCR_1 are B'100, TCNT_1 counts the occurrence of compare-match A for TMR_0. TMR_0 and TMR_1 are controlled independently. Conditions such as setting of the CMF flag, generation of interrupts, output from the TMO pin, and counter clearing are in accordance with the settings for each of TMR_0 and TMR_1.

10.7 TMR_Y and TMR_X Cascaded Connection

If bits CKS2 to CKS0 in either TCR_Y or TCR_X are set to B'100, the 8-bit timers of the two channels are cascaded. With this configuration, 16-bit count mode or compare-match count mode can be selected by the settings of the CKSX and CKSY bits in TCRXY.

10.7.1 16-Bit Count Mode

When bits CKS2 to CKS0 in TCR_Y are set to B'100 and the CKSY bit in TCRXY is set to 1, the timer functions as a single 16-bit timer with TMR_Y occupying the upper eight bits and TMR_X occupying the lower 8 bits.

Setting of compare-match flags

The CMF flag in TCSR_Y is set to 1 when an upper 8-bit compare-match occurs.

The CMF flag in TCSR_X is set to 1 when a lower 8-bit compare-match occurs.

Counter clear specification

If the CCLR1 and CCLR0 bits in TCR_Y have been set for counter clear at compare-match, only the upper eight bits of TCNT_Y are cleared. The upper eight bits of TCNT_Y are also cleared when counter clear by the TMRIY pin has been set.

The settings of the CCLR1 and CCLR0 bits in TCR_X are enabled, and the lower 8 bits of TCNT_X can be cleared by the counter.

Pin output

Control of output from the TMOY pin by bits OS3 to OS0 in TCSR_Y is in accordance with the upper 8-bit compare-match conditions.

Control of output from the TMOX pin by bits OS3 to OS0 in TCSR_X is in accordance with the lower 8-bit compare-match conditions.

Note: The program development tool (emulator) does not support 16-bit count mode.

10.7.2 Compare-Match Count Mode

When bits CKS2 to CKS0 in TCR_X are set to B'100 and the CKSX bit in TCRXY is set to 1, TCNT_X counts the occurrence of compare-match A for TMR_Y. TMR_X and TMR_Y are controlled independently. Conditions such as setting of the CMF flag, generation of interrupts, output from the TMO pin, and counter clearing are in accordance with the settings for each channel.

Note: The program development tool (emulator) does not support compare-match count mode.

10.7.3 Input Capture Operation

TMR_X has input capture registers (TICRR and TICRF). A narrow pulse width can be measured with TICRR and TICRF, using a single capture. If the falling edge of TMRX (TMR_X input capture input signal) is detected after its rising edge has been detected, the value of TCNT_X at that time is transferred to both TICRR and TICRF.

10.8 TMR_B and TMR_A Cascaded Connection

If bits CKS2 to CKS0 in either TCR_B or TCR_A are set to B'100, the 8-bit timers of the two channels are cascaded. With this configuration, 16-bit count mode or compare-match count mode can be selected by the settings of the CKSA and CKSB bits in TCRAB.

10.8.1 16-Bit Count Mode

When bits CKS2 to CKS0 in TCR_B are set to B'100 and the CKSB bit in TCRAB is set to 1, the timer functions as a single 16-bit timer with TMR_B occupying the upper eight bits and TMR_A occupying the lower 8 bits.

Setting of compare-match flags

The CMF flag in TCSR_B is set to 1 when an upper 8-bit compare-match occurs.

The CMF flag in TCSR_A is set to 1 when a lower 8-bit compare-match occurs.

Counter clear specification

If the CCLR1 and CCLR0 bits in TCR_B have been set for counter clear at compare-match, only the upper eight bits of TCNT_B are cleared. The upper eight bits of TCNT_B are also cleared when counter clear by the TMRIB pin has been set.

The settings of the CCLR1 and CCLR0 bits in TCR_A are enabled, and the lower 8 bits of TCNT_A can be cleared by the counter.

Pin output

Control of output from the TMOB pin by bits OS3 to OS0 in TCSR_B is in accordance with the upper 8-bit compare-match conditions.

Control of output from the TMOA pin by bits OS3 to OS0 in TCSR_A is in accordance with the lower 8-bit compare-match conditions.

10.8.2 Compare-Match Count Mode

When bits CKS2 to CKS0 in TCR_A are set to B'100 and the CKSA bit in TCRAB is set to 1, TCNT_A counts the occurrence of compare-match A for TMR_B. TMR_A and TMR_B are controlled independently. Conditions such as setting of the CMF flag, generation of interrupts, output from the TMO pin, and counter clearing are in accordance with the settings for each channel.

10.8.3 Input Capture Operation

TMR_A has input capture registers (TICRR_A and TICRF_A). A narrow pulse width can be measured with TICRR and TICRF, using a single capture. If the falling edge of TMR1A (TMR_A input capture input signal) is detected after its rising edge has been detected, the value of TCNT_A at that time is transferred to both TICRR and TICRF.

Input Capture Signal Input Timing: Figure 10.12 shows the timing of the input capture operation.

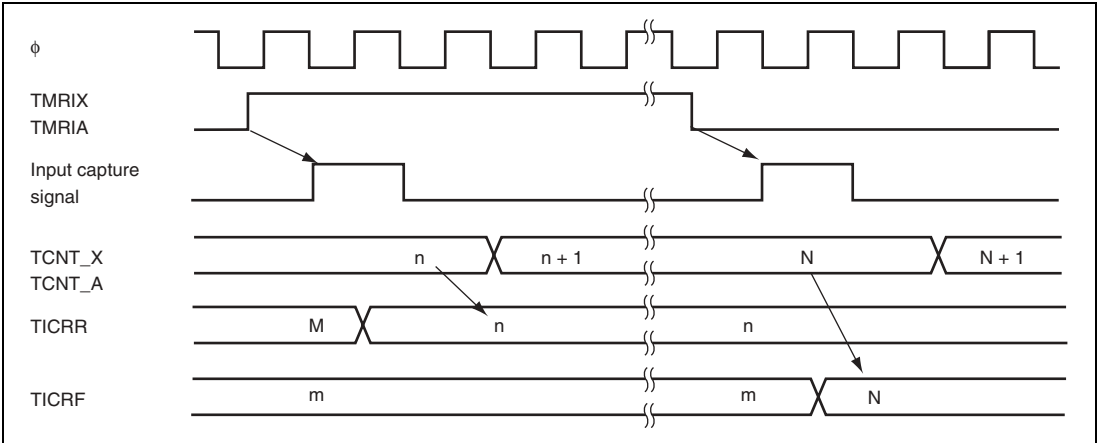

Figure 10.12 Timing of Input Capture Operation

If the input capture signal is input while TICRR and TICRF are being read, the input capture signal is delayed by one system clock (ϕ) cycle. Figure 10.13 shows the timing of this operation.

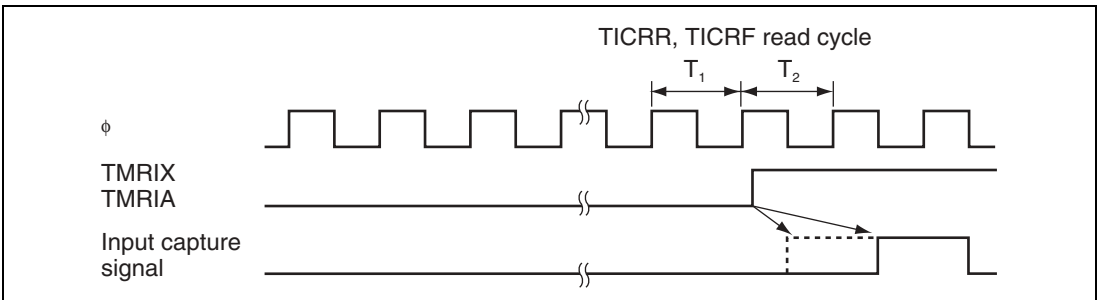

Figure 10.13 Timing of Input Capture Signal (Input capture signal is input during TICRR and TICRF read)

Selection of Input Capture Signal Input: TMR_{IX} (input capture input signal of TMR_X) is selected according to the setting of the ICST bit in TCONRI. The input capture signal selection is shown in table 10.5.

Table 10.5 Input Capture Signal Selection

TCONRI	
Bit 4	
ICST	Description
0	Input capture function not used
1	TMI _X pin input selection

TMR_{IA} (input capture input signal of TMR_A) is selected according to the setting of the ICST bit in TCRA_B. The input capture signal selection is shown in table 10.6.

Table 10.6 Input Capture Signal Selection

TCRA_B	
Bit 3	
ICST	Description
0	Input capture function not used
1	TMI _A pin input selection

10.9 Interrupt Sources

TMR_0, TMR_1, and TMR_Y can generate three types of interrupts: CMIA, CMIB, and OVI. TMR_X can generate an ICIX interrupt. TMR_A can generate four types of interrupts, CMIA, CMIB, OVI and ICIA. Table 10.7 shows the interrupt sources and priorities. Each interrupt source can be enabled or disabled independently by interrupt enable bits in TCR or TCSR. Independent signals are sent to the interrupt controller for each interrupt.

Table 10.7 Interrupt Sources of 8-Bit Timers TMR_0, TMR_1, TMR_Y, TMR_X TMR_B, and TMR_A

Channel	Name	Interrupt Source	Interrupt Flag	Interrupt Priority
TMR_0	CMIA0	TCORA_0 compare-match	CMFA	High ↑
	CMIB0	TCORB_0 compare-match	CMFB	
	OVI0	TCNT_0 overflow	OVF	
TMR_1	CMIA1	TCORA_1 compare-match	CMFA	↑
	CMIB1	TCORB_1 compare-match	CMFB	
	OVI1	TCNT_1 overflow	OVF	
TMR_Y	CMIA _Y	TCORA_ _Y compare-match	CMFA	↑
	CMIB _Y	TCORB_ _Y compare-match	CMFB	
	OVI _Y	TCNT_ _Y overflow	OVF	
TMR_X	ICIX	Input capture	ICF	↑
TMR_B, TMR_A	CMIAAB	TCORA_A, TCORA_B compare-match*	CMFA	
	CMIBAB	TCORB_A, TCORB_B compare-match*	CMFB	
	OVIAB	TCNT_A, TCNT_B overflow*	OVF	
TMR_A	ICIA	Input capture	ICF	Low

Note: * The interrupt sources for TMR_B and TMR_A are allocated to the same vector addresses. The bits CMIEB, CMIEA, and OVIE in TCR register of TMR_B or TMR_A should be set to 1.

10.10 Usage Notes

10.10.1 Conflict between TCNT Write and Counter Clear

If a counter clear signal is generated during the T_2 state of a TCNT write cycle as shown in figure 10.14, clearing takes priority and the counter write is not performed.

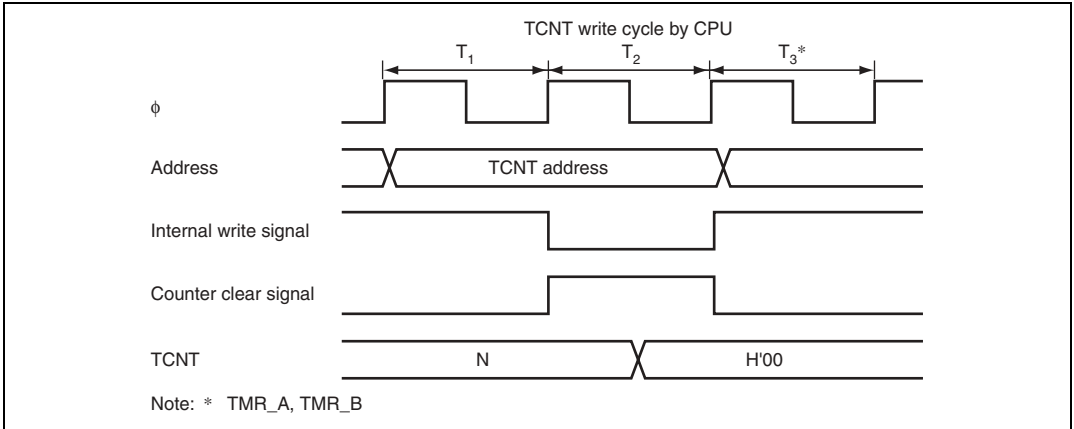

Figure 10.14 Conflict between TCNT Write and Clear

10.10.2 Conflict between TCNT Write and Count-Up

If a count-up occurs during the T_2 state of a TCNT write cycle as shown in figure 10.15, the counter write takes priority and the counter is not incremented.

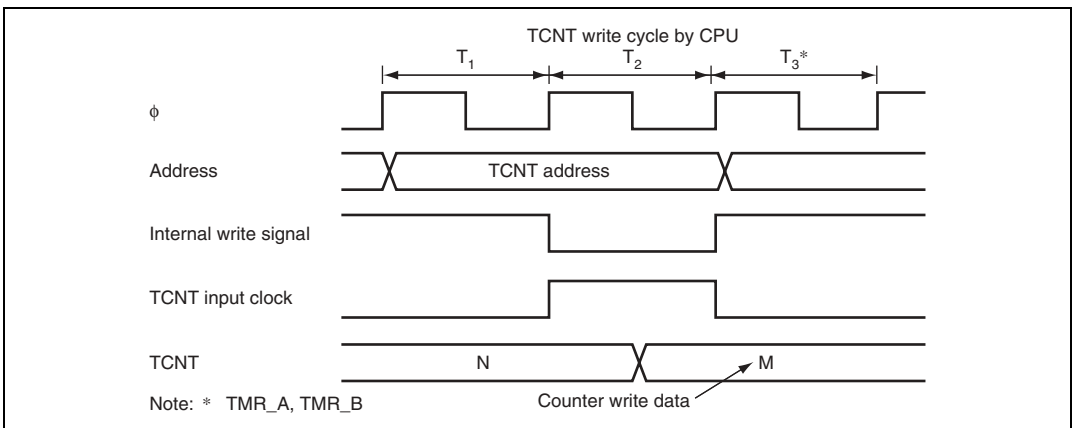

Figure 10.15 Conflict between TCNT Write and Count-Up

10.10.3 Conflict between TCOR Write and Compare-Match

If a compare-match occurs during the T_2 state of a TCOR write cycle as shown in figure 10.16, the TCOR write takes priority and the compare-match signal is disabled. With TMR_X, and TMR_A, a TICR input capture conflicts with a compare-match in the same way as with a write to TCORC. In this case also, the input capture takes priority and the compare-match signal is disabled.

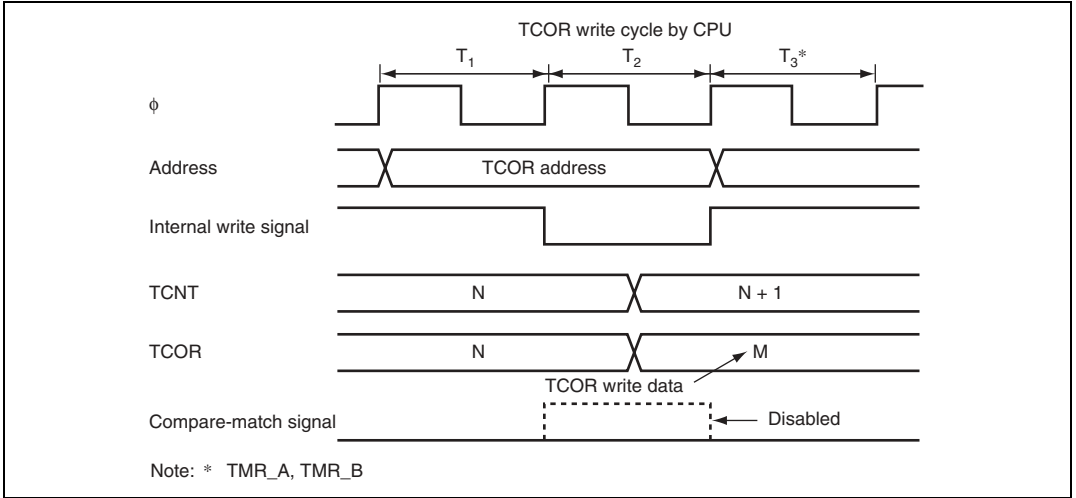

Figure 10.16 Conflict between TCOR Write and Compare-Match

10.10.4 Conflict between Compare-Matches A and B

If compare-matches A and B occur at the same time, the operation follows the output status that is defined for compare-match A or B, according to the priority of the timer output shown in table 10.8.

Table 10.8 Timer Output Priorities

Output Setting	Priority
Toggle output	High
1 output	↑
0 output	↑
No change	Low

10.10.5 Switching of Internal Clocks and TCNT Operation

TCNT may increment erroneously when the internal clock is switched over. Table 10.9 shows the relationship between the timing at which the internal clock is switched (by writing to the CKS1 and CKS0 bits) and the TCNT operation.

When the TCNT clock is generated from an internal clock, the falling edge of the internal clock pulse is detected. If clock switching causes a change from high to low level, as shown in no. 3 in table 10.9, a TCNT clock pulse is generated on the assumption that the switchover is a falling edge, and TCNT is incremented.

Erroneous incrementation can also happen when switching between internal and external clocks.

Table 10.9 Switching of Internal Clocks and TCNT Operation

No.	Timing of Switchover by Means of CKS1 and CKS0 Bits	TCNT Clock Operation
1	Clock switching from low to low level* ¹	
2	Clock switching from low to high level* ²	

Timing of Switchover by Means of CKS1 and CKS0 Bits

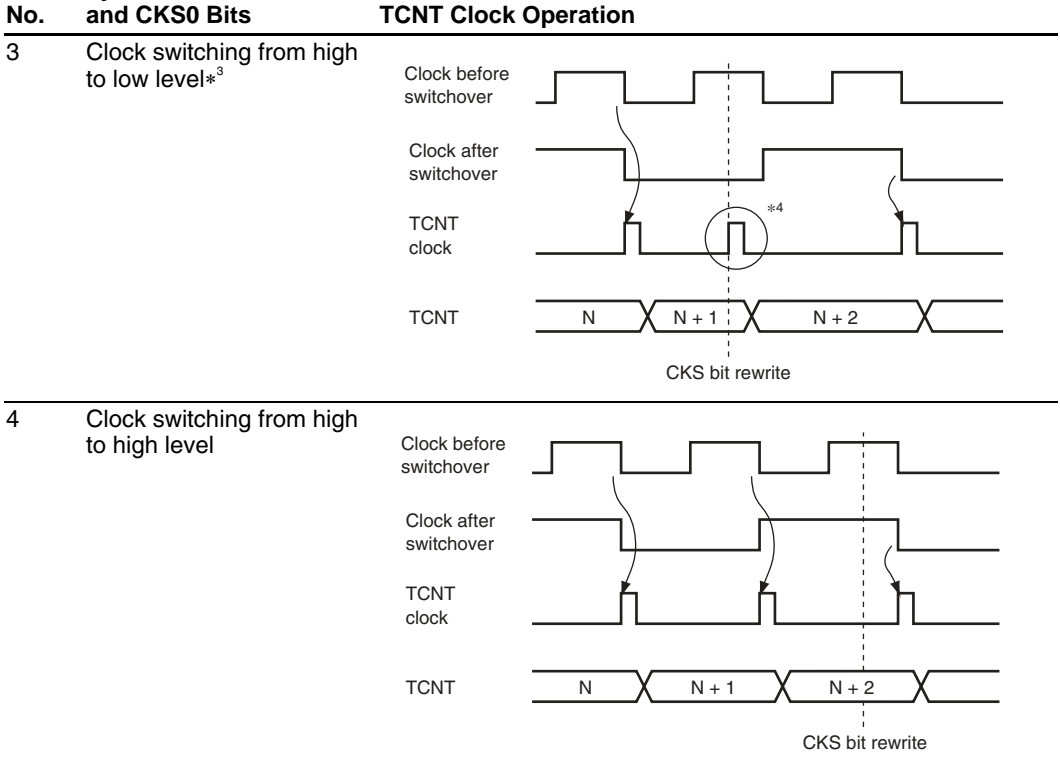

- Notes:
1. Includes switching from low to stop, and from stop to low.
 2. Includes switching from stop to high.
 3. Includes switching from high to stop.
 4. Generated on the assumption that the switchover is a falling edge; TCNT is incremented.

10.10.6 Mode Setting with Cascaded Connection

If the 16-bit count mode and compare-match count mode are set simultaneously, the input clock pulses for TCNT_0 and TCNT_1, and TCNT_X and TCNT_Y and TCNT_A and TCNT_B are not generated, and thus the counters will stop operating. Simultaneous setting of these two modes should therefore be avoided.

10.10.7 Module Stop Mode Setting

TMR operation can be enabled or disabled using the module stop control register. The initial setting is for TMR operation to be halted. Register access is enabled by canceling the module stop mode. For details, refer to section 20, Power-Down Modes.

Section 11 Watchdog Timer (WDT)

This LSI incorporates two watchdog timer channels (WDT_0 and WDT_1). The watchdog timer can generate an internal reset signal or an internal NMI interrupt signal if a system crash prevents the CPU from writing to the timer counter, thus allowing it to overflow. Simultaneously, it can output an overflow signal (RESO) externally.

When this watchdog function is not needed, the WDT can be used as an interval timer. In interval timer operation, an interval timer interrupt is generated each time the counter overflows. A block diagram of the WDT_0 and WDT_1 is shown in figure 11.1.

11.1 Features

- Selectable from eight (WDT_0) or 16 (WDT_1) counter input clocks.
- Switchable between watchdog timer mode and interval timer mode

Watchdog Timer Mode:

- If the counter overflows, an internal reset or an internal NMI interrupt is generated.
- When the LSI is selected to be internally reset at counter overflow, a low level signal is output from the RESO pin if the counter overflows.

Internal Timer Mode:

- If the counter overflows, an internal timer interrupt (WOVI) is generated.

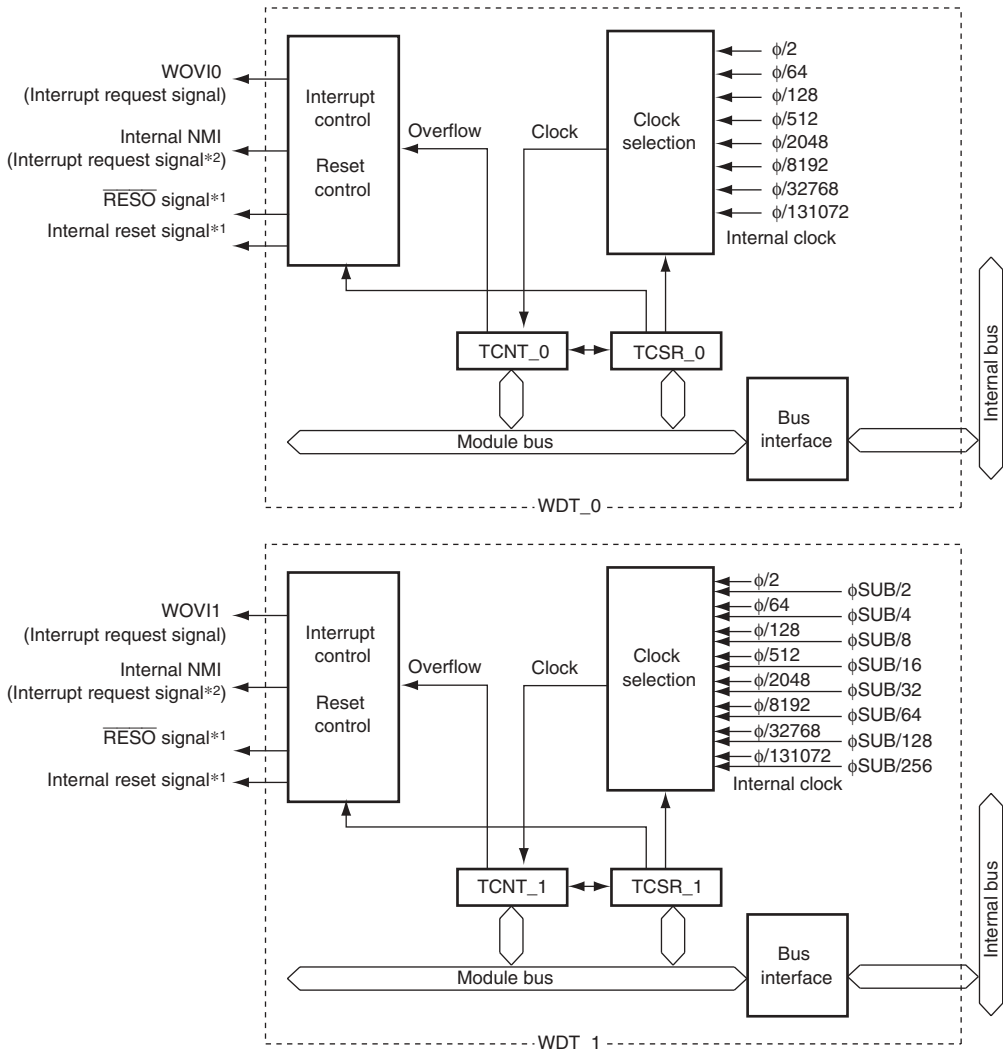

[Legend]

TCSR_0 : Timer control/status register_0

TCNT_0 : Timer counter_0

TCSR_1 : Timer control/status register_1

TCNT_1 : Timer counter_1

- Notes: 1. The \overline{RESO} signal outputs the low level signal when the internal reset signal is generated due to a TCNT overflow of either WDT_0 or WDT_1. The internal reset signal first resets the WDT in which the overflow has occurred first.
2. The internal NMI interrupt signal can be independently output from either WDT_0 or WDT_1. The interrupt controller does not distinguish the NMI interrupt request from WDT_0 from that from WDT_1.

Figure 11.1 Block Diagram of WDT

11.2 Input/Output Pins

The WDT has the pins listed in table 11.1.

Table 11.1 Pin Configuration

Name	Symbol	I/O	Function
Reset output pin	RESO	Output	Outputs the counter overflow signal in watchdog timer mode
External sub-clock input pin	EXCL	Input	Inputs the clock pulses to the WDT_1 prescaler counter

11.3 Register Descriptions

The WDT has the following registers. To prevent accidental overwriting, TCSR and TCNT have to be written to in a method different from normal registers. For details, refer to section 11.6.1, Notes on Register Access. For details on the system control register, refer to section 3.2.2, System Control Register (SYSCR).

- Timer counter (TCNT)
- Timer control/status register (TCSR)

11.3.1 Timer Counter (TCNT)

TCNT is an 8-bit readable/writable up-counter.

TCNT is initialized to H'00 when the TME bit in the timer control/status register (TCSR) is cleared to 0.

11.3.2 Timer Control/Status Register (TCSR)

TCSR selects the clock source to be input to TCNT, and the timer mode.

- TCSR_0

Bit	Bit Name	Initial Value	R/W	Description
7	OVF	0	R/(W)* ¹	<p>Overflow Flag</p> <p>Indicates that TCNT has overflowed (changes from H'FF to H'00).</p> <p>[Setting condition]</p> <p>When TCNT overflows (changes from H'FF to H'00)</p> <p>However, when internal reset request generation is selected in watchdog timer mode, OVF is cleared automatically by the internal reset.</p> <p>[Clearing conditions]</p> <ul style="list-style-type: none"> • When TCSR is read when $OVF = 1^{*2}$, then 0 is written to OVF • When 0 is written to TME
6	WT/ \overline{IT}	0	R/W	<p>Timer Mode Select</p> <p>Selects whether the WDT is used as a watchdog timer or interval timer.</p> <p>0: Interval timer mode</p> <p>1: Watchdog timer mode</p>
5	TME	0	R/W	<p>Timer Enable</p> <p>When this bit is set to 1, TCNT starts counting.</p> <p>When this bit is cleared, TCNT stops counting and is initialized to H'00.</p>
4	—	0	R/(W)	<p>Reserved</p> <p>The initial value should not be modified.</p>
3	RST/ \overline{NMI}	0	R/W	<p>Reset or NMI</p> <p>Selects to request an internal reset or an NMI interrupt when TCNT has overflowed.</p> <p>0: An NMI interrupt is requested</p> <p>1: An internal reset is requested</p>

Bit	Bit Name	Initial Value	R/W	Description
2	CKS2	0	R/W	Clock Select 2 to 0
1	CKS1	0	R/W	Selects the clock source to be input to. The overflow frequency for $\phi = 10$ MHz is enclosed in parentheses.
0	CKS0	0	R/W	000: $\phi/2$ (frequency: 51.2 μ s) 001: $\phi/64$ (frequency: 1.64 ms) 010: $\phi/128$ (frequency: 3.28 ms) 011: $\phi/512$ (frequency: 13.1 ms) 100: $\phi/2048$ (frequency: 52.4 ms) 101: $\phi/8192$ (frequency: 209.7 ms) 110: $\phi/32768$ (frequency: 0.84 s) 111: $\phi/131072$ (frequency: 3.36 s)

Notes: 1. Only 0 can be written, to clear the flag.

2. When OVF is polled with the interval timer interrupt disabled, OVF = 1 must be read at least twice.

- TCSR_1

Bit	Bit Name	Initial Value	R/W	Description
7	OVF	0	R/(W)* ¹	Overflow Flag Indicates that TCNT has overflowed (changes from H'FF to H'00). [Setting condition] When TCNT overflows (changes from H'FF to H'00) However, when internal reset request generation is selected in watchdog timer mode, OVF is cleared automatically by the internal reset. [Clearing conditions] When TCSR is read when OVF = 1* ² , then 0 is written to OVF When 0 is written to TME
6	WT/IT	0	R/W	Timer Mode Select Selects whether the WDT is used as a watchdog timer or interval timer. 0: Interval timer mode 1: Watchdog timer mode
5	TME	0	R/W	Timer Enable When this bit is set to 1, TCNT starts counting. When this bit is cleared, TCNT stops counting and is initialized to H'00.

Bit	Bit Name	Initial Value	R/W	Description
4	PSS	0	R/W	<p>Prescaler Select</p> <p>Selects the clock source to be input to TCNT.</p> <p>0: Counts the divided cycle of ϕ-based prescaler (PSM)</p> <p>1: Counts the divided cycle of ϕSUB-based prescaler (PSS)</p>
3	RST/ $\overline{\text{NMI}}$	0	R/W	<p>Reset or NMI</p> <p>Selects to request an internal reset or an NMI interrupt when TCNT has overflowed.</p> <p>0: An NMI interrupt is requested</p> <p>1: An internal reset is requested</p>
2	CKS2	0	R/W	Clock Select 2 to 0
1	CKS1	0	R/W	<p>Selects the clock source to be input to TCNT. The overflow cycle for $\phi = 10$ MHz and ϕSUB = 32.768 kHz is enclosed in parentheses.</p> <p>When PSS = 0:</p> <p>000: $\phi/2$ (frequency: 51.2 μs)</p> <p>001: $\phi/64$ (frequency: 1.64 ms)</p> <p>010: $\phi/128$ (frequency: 3.28 ms)</p> <p>011: $\phi/512$ (frequency: 13.1 ms)</p> <p>100: $\phi/2048$ (frequency: 52.4 ms)</p> <p>101: $\phi/8192$ (frequency: 209.7 ms)</p> <p>110: $\phi/32768$ (frequency: 0.84 s)</p> <p>111: $\phi/131072$ (frequency: 3.36 s)</p> <p>When PSS = 1:</p> <p>000: ϕSUB/2 (cycle: 15.6 ms)</p> <p>001: ϕSUB/4 (cycle: 31.3 ms)</p> <p>010: ϕSUB/8 (cycle: 62.5 ms)</p> <p>011: ϕSUB/16 (cycle: 125 ms)</p> <p>100: ϕSUB/32 (cycle: 250 ms)</p> <p>101: ϕSUB/64 (cycle: 500 ms)</p> <p>110: ϕSUB/128 (cycle: 1 s)</p> <p>111: $\phi/256$ (cycle: 2 s)</p>
0	CKS0	0	R/W	

- Notes: 1. Only 0 can be written, to clear the flag.
2. When OVF is polled with the interval timer interrupt disabled, OVF = 1 must be read at least twice.

11.4 Operation

11.4.1 Watchdog Timer Mode

To use the WDT as a watchdog timer, set the $\overline{WT/IT}$ bit and the TME bit in TCSR to 1. While the WDT is used as a watchdog timer, if TCNT overflows without being rewritten because of a system malfunction or another error, an internal reset or NMI interrupt request is generated. TCNT does not overflow while the system is operating normally. Software must prevent TCNT overflows by rewriting the TCNT value (normally by writing H'00) before overflows occurs.

If the $\overline{RST/NMI}$ bit of TCSR is set to 1, when the TCNT overflows, an internal reset signal for this LSI is issued for 518 system clocks, and the low level signal is simultaneously output from the \overline{RESO} pin for 132 states, as shown in figure 11.2. If the $\overline{RST/NMI}$ bit is cleared to 0, when the TCNT overflows, an NMI interrupt request is generated. Here, the output from the \overline{RESO} pin remains high.

An internal reset request from the watchdog timer and a reset input from the \overline{RES} pin are processed in the same vector. Reset source can be identified by the XRST bit status in SYSCR. If a reset caused by a signal input to the \overline{RES} pin occurs at the same time as a reset caused by a WDT overflow, the \overline{RES} pin reset has priority and the XRST bit in SYSCR is set to 1.

An NMI interrupt request from the watchdog timer and an interrupt request from the NMI pin are processed in the same vector. Do not handle an NMI interrupt request from the watchdog timer and an interrupt request from the NMI pin at the same time.

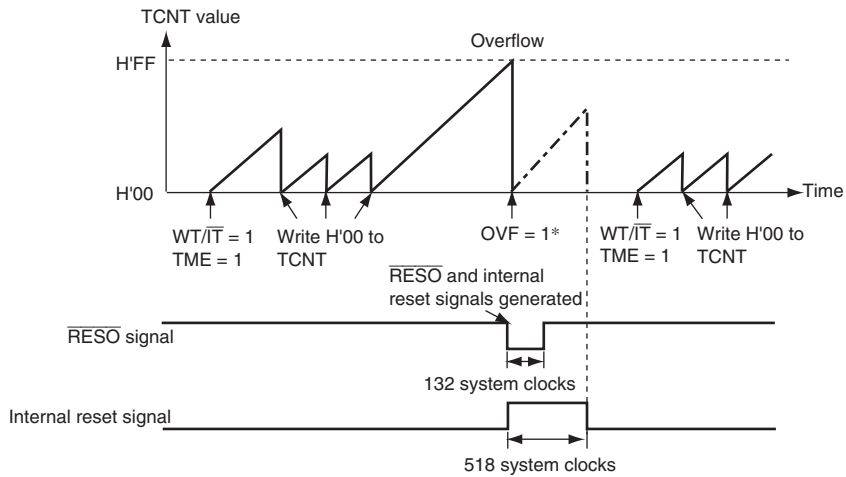

[Legend]

WT/\overline{IT} : Timer mode select bit

TME : Timer enable bit

OVF : Overflow flag

Note: * After the OVF bit becomes 1, it is cleared to 0 by an internal reset.
The $XRST$ bit is also cleared to 0.

Figure 11.2 Watchdog Timer Mode ($\overline{RST}/\overline{NMI} = 1$) Operation

11.4.2 Interval Timer Mode

When the WDT is used as an interval timer, an interval timer interrupt (WOVI) is generated each time the TCNT overflows, as shown in figure 11.3. Therefore, an interrupt can be generated at intervals.

When the TCNT overflows in interval timer mode, an interval timer interrupt (WOVI) is requested at the same time the OVF bit of TCSR is set to 1. The timing is shown figure 11.4.

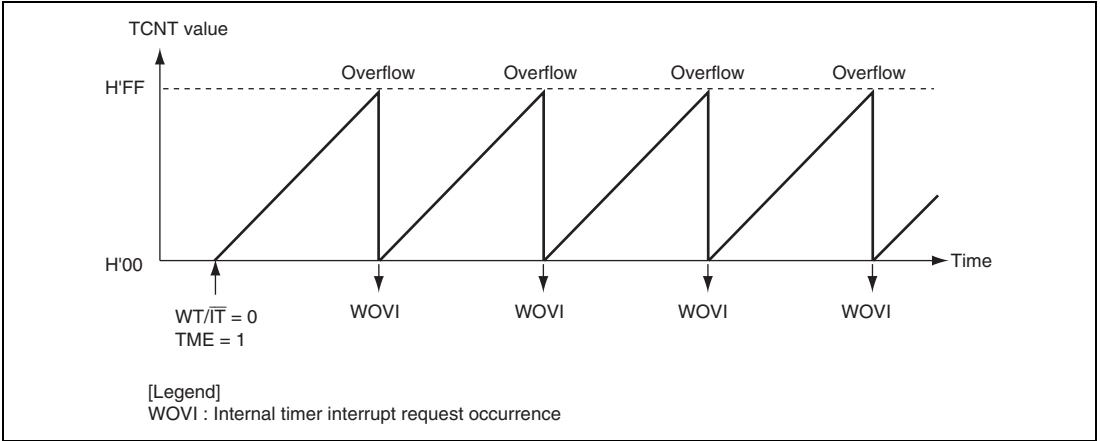

Figure 11.3 Interval Timer Mode Operation

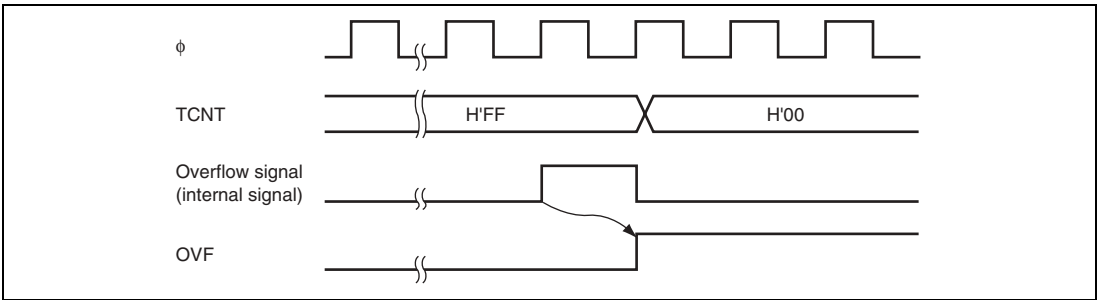

Figure 11.4 OVF Flag Set Timing

11.4.3 $\overline{\text{RESO}}$ Signal Output Timing

When TCNT overflows in watchdog timer mode, the OVF bit in TCSR is set to 1. When the RST/NMI bit is 1 here, the internal reset signal is generated for the entire LSI. At the same time, the low level signal is output from the $\overline{\text{RESO}}$ pin. The timing is shown in figure 11.5.

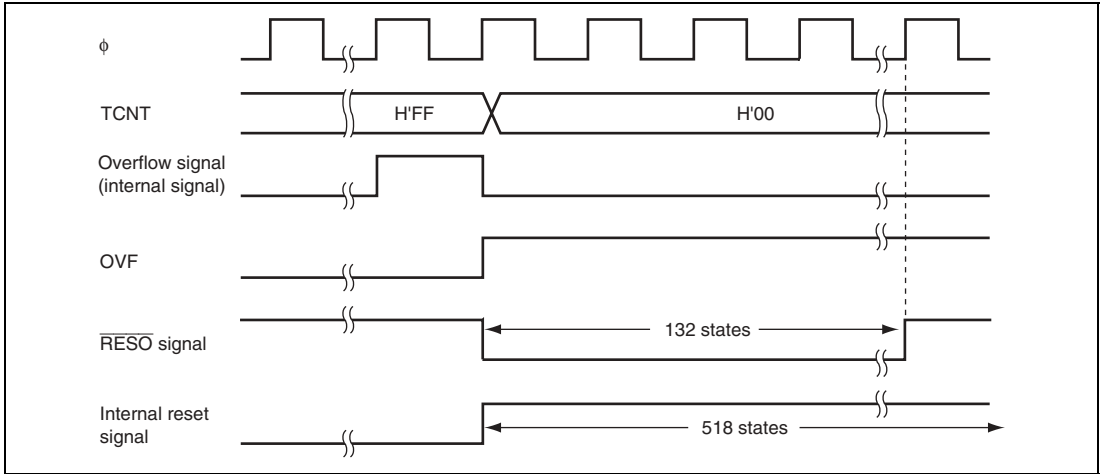

Figure 11.5 Output Timing of $\overline{\text{RESO}}$ signal

11.5 Interrupt Sources

During interval timer mode operation, an overflow generates an interval timer interrupt (WOVI). The interval timer interrupt is requested whenever the OVF flag is set to 1 in TCSR. OVF must be cleared to 0 in the interrupt handling routine.

When the NMI interrupt request is selected in watchdog timer mode, an NMI interrupt request is generated by an overflow.

Table 11.2 WDT Interrupt Source

Name	Interrupt Source	Interrupt Flag
WOVI	TCNT overflow	OVF

11.6 Usage Notes

11.6.1 Notes on Register Access

The watchdog timer's registers, TCNT and TCSR differ from other registers in being more difficult to write to. The procedures for writing to and reading from these registers are given below.

Writing to TCNT and TCSR (Example of WDT_0): These registers must be written to by a word transfer instruction. They cannot be written to by a byte transfer instruction.

TCNT and TCSR both have the same write address. Therefore, satisfy the relative condition shown in figure 11.6 to write to TCNT or TCSR. To write to TCNT, the upper bytes must contain the value H'5A and the lower bytes must contain the write data before the transfer instruction execution. To write to TCSR, the upper bytes must contain the value H'A5 and the lower bytes must contain the write data.

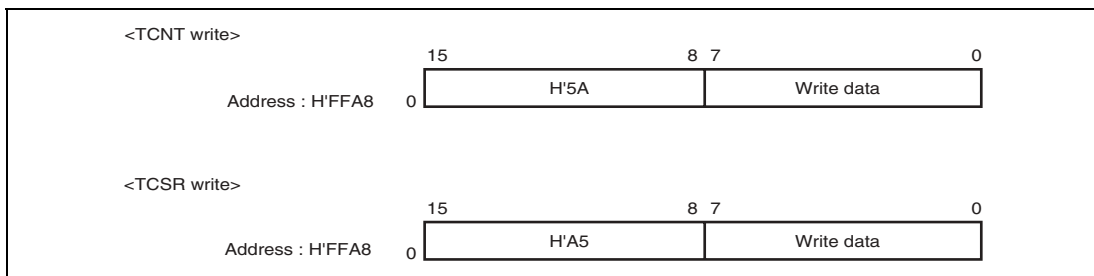

Figure 11.6 Writing to TCNT and TCSR (WDT_0)

Reading from TCNT and TCSR (Example of WDT_0): These registers are read in the same way as other registers. The read address is H'FFA8 for TCSR and H'FFA9 for TCNT.

11.6.2 Conflict between Timer Counter (TCNT) Write and Increment

If a timer counter clock pulse is generated during the T2 state of a TCNT write cycle, the write takes priority and the timer counter is not incremented. Figure 11.7 shows this operation.

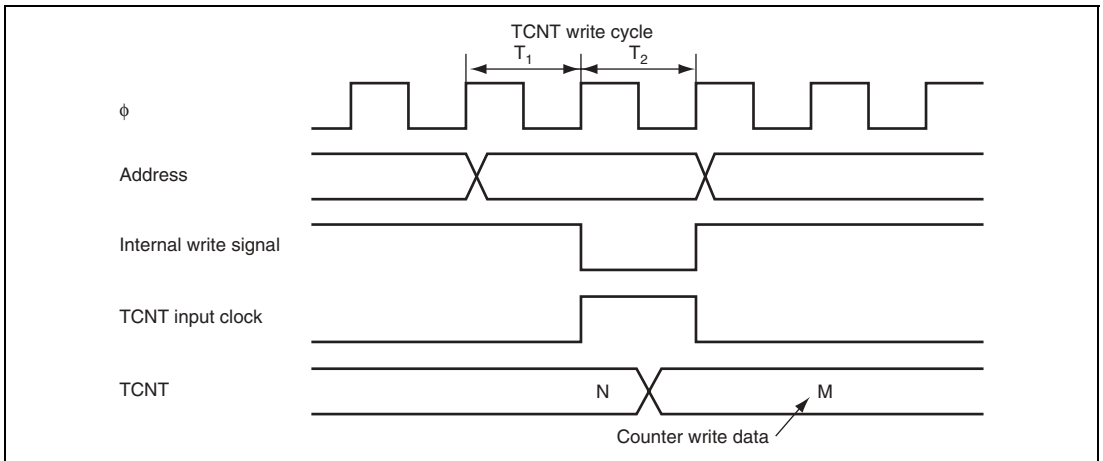

Figure 11.7 Conflict between TCNT Write and Increment

11.6.3 Changing Values of CKS2 to CKS0 Bits

If bits CKS2 to CKS0 in TCSR are written to while the WDT is operating, errors could occur in the incrementation. Software must stop the watchdog timer (by clearing the TME bit to 0) before changing the values of bits CKS2 to CKS0.

11.6.4 Switching between Watchdog Timer Mode and Interval Timer Mode

If the mode is switched from watchdog timer to interval timer, while the WDT is operating, errors could occur in the incrementation. Software must stop the watchdog timer (by clearing the TME bit to 0) before switching the mode.

11.6.5 System Reset by $\overline{\text{RESO}}$ Signal

Inputting the $\overline{\text{RESO}}$ output signal to the $\overline{\text{RESO}}$ pin of this LSI prevents the LSI from being initialized correctly; the $\overline{\text{RESO}}$ signal must not be logically connected to the $\overline{\text{RES}}$ pin of the LSI. To reset the entire system by the $\overline{\text{RESO}}$ signal, use the circuit as shown in figure 11.8.

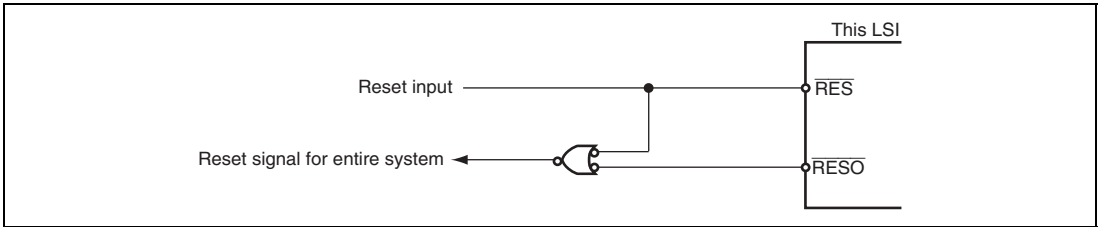

Figure 11.8 Sample Circuit for Resetting System by $\overline{\text{RESO}}$ Signal

11.6.6 Counter Values during Transitions between High-Speed, Sub-Active, and Watch Modes

When developing a program with a program development tool (emulator), pay attention to the followings.

When WDT_1 is used as a clock counter and is allowed to transit between high-speed mode and sub-active or watch mode, the counter does not display the correct value due to internal clock switching.

Specifically, when transiting from high-speed mode to sub-active or watch mode, that is, when the control clock for WDT_1 switches from the main clock to the sub-clock, the counter incrementing timing is delayed for approximately two to three clock cycles.

Similarly, when transiting from sub-active or watch mode to high-speed mode, the clock is not supplied until stabilized internal oscillation is available because the main clock oscillator is halted in sub-clock mode. The counter is therefore prevented from incrementing for the time specified by the STS2 to STS0 bits in SBYCR after internal oscillation starts, thus producing counter value differences for this time.

Special care must be taken when using WDT_1 as a clock counter. Note that no counter value difference is produced while operated in the same mode.

Section 12 Serial Communication Interface (SCI)

This LSI has a serial communication interface (SCI). The SCI can handle both asynchronous and clocked synchronous serial communication. Asynchronous serial data communication can be carried out with standard asynchronous communication chips such as a Universal Asynchronous Receiver/Transmitter (UART) or Asynchronous Communication Interface Adapter (ACIA). A function is also provided for serial communication between processors (multiprocessor communication function) in asynchronous mode.

12.1 Features

- Choice of asynchronous or clocked synchronous serial communication mode
- Full-duplex communication capability
The transmitter and receiver are mutually independent, enabling transmission and reception to be executed simultaneously. Double-buffering is used in both the transmitter and the receiver, enabling continuous transmission and continuous reception of serial data.
- The on-chip baud rate generator allows any bit rate to be selected
An external clock can be selected as a transfer clock source.
- Choice of LSB-first or MSB-first transfer (except in the case of asynchronous mode 7-bit data)
- Four interrupt sources
Four interrupt sources — transmit-end, transmit-data-empty, receive-data-full, and receive error — that can issue requests.

Asynchronous Mode:

- Data length: 7 or 8 bits
- Stop bit length: 1 or 2 bits
- Parity: Even, odd, or none
- Receive error detection: Parity, overrun, and framing errors
- Break detection: Break can be detected by reading the RxD pin level directly in case of a framing error

Clocked Synchronous Mode:

- Data length: 8 bits
- Receive error detection: Overrun errors
- Serial data communication with other LSIs that have the clock synchronized communication function

A block diagram of the SCI is shown in figure 12.1.

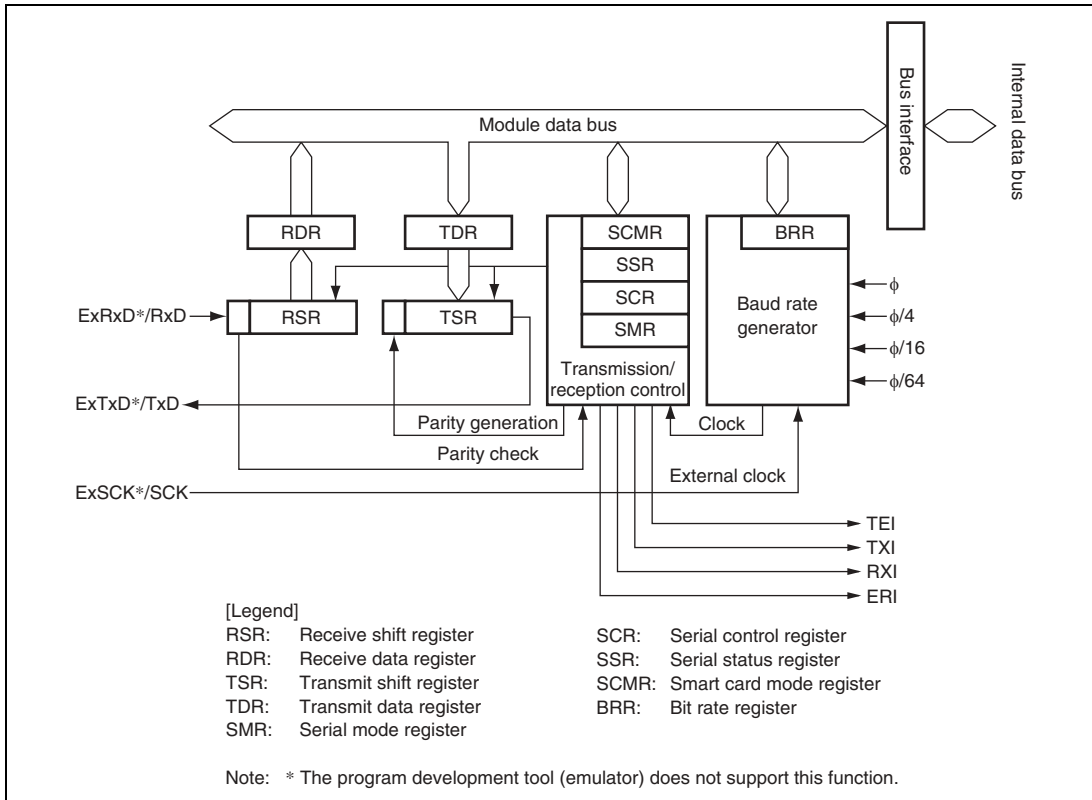

Figure 12.1 Block Diagram of SCI

12.2 Input/Output Pins

Table 12.1 shows the input/output pins for each SCI channel.

Table 12.1 Pin Configuration

Channel	Symbol* ¹	Input/Output	Function
1	SCK1/ ExSCK1* ²	Input/Output	Channel 1 clock input/output
	RxD1/ ExRxD1* ²	Input	Channel 1 receive data input
	TxD1/ ExTxD1* ²	Output	Channel 1 transmit data output

Notes: 1. Pin names SCK, RxD, and TxD are used in the text for all channels, omitting the channel designation.

2. The program development tool (emulator) does not support this function.

12.3 Register Descriptions

The SCI has the following registers.

- Receive shift register (RSR)
- Receive data register (RDR)
- Transmit data register (TDR)
- Transmit shift register (TSR)
- Serial mode register (SMR)
- Serial control register (SCR)
- Serial status register (SSR)
- Serial interface mode register (SCMR)
- Bit rate register (BRR)
- Serial pin select register (SPSR)*

Note: * The program development tool (emulator) does not support this function.

12.3.1 Receive Shift Register (RSR)

RSR is a shift register used to receive serial data that converts it into parallel data. When one frame of data has been received, it is transferred to RDR automatically. RSR cannot be directly accessed by the CPU.

12.3.2 Receive Data Register (RDR)

RDR is an 8-bit register that stores receive data. When the SCI has received one frame of serial data, it transfers the received serial data from RSR to RDR where it is stored. After this, RSR can receive the next data. Since RSR and RDR function as a double buffer in this way, continuous receive operations can be performed. After confirming that the RDRF bit in SSR is set to 1, read RDR for only once. RDR cannot be written to by the CPU. RDR is initialized to H'00.

12.3.3 Transmit Data Register (TDR)

TDR is an 8-bit register that stores transmit data. When the SCI detects that TSR is empty, it transfers the transmit data written in TDR to TSR and starts transmission. The double-buffered structures of TDR and TSR enables continuous serial transmission. If the next transmit data has already been written to TDR when one frame of data is transmitted, the SCI transfers the written data to TSR to continue transmission. Although TDR can be read from or written to by the CPU at all times, to achieve reliable serial transmission, write transmit data to TDR for only once after confirming that the TDRE bit in SSR is set to 1. TDR is initialized to H'FF.

12.3.4 Transmit Shift Register (TSR)

TSR is a shift register that transmits serial data. To perform serial data transmission, the SCI first transfers transmit data from TDR to TSR, then sends the data to the TxD pin. TSR cannot be directly accessed by the CPU.

12.3.5 Serial Mode Register (SMR)

SMR is used to set the SCI's serial transfer format and select the on-chip baud rate generator clock source.

Bit	Bit Name	Initial Value	R/W	Description
7	C/ \bar{A}	0	R/W	Communication Mode 0: Asynchronous mode 1: Clocked synchronous mode
6	CHR	0	R/W	Character Length (enabled only in asynchronous mode) 0: Selects 8 bits as the data length. 1: Selects 7 bits as the data length. LSB-first is fixed and the MSB of TDR is not transmitted in transmission. In clocked synchronous mode, a fixed data length of 8 bits is used.
5	PE	0	R/W	Parity Enable (enabled only in asynchronous mode) When this bit is set to 1, the parity bit is added to transmit data before transmission, and the parity bit is checked in reception. For a multiprocessor format, parity bit addition and checking are not performed regardless of the PE bit setting.
4	O/ \bar{E}	0	R/W	Parity Mode (enabled only when the PE bit is 1 in asynchronous mode) 0: Selects even parity. 1: Selects odd parity.
3	STOP	0	R/W	Stop Bit Length (enabled only in asynchronous mode) Selects the stop bit length in transmission. 0: 1 stop bit 1: 2 stop bits In reception, only the first stop bit is checked. If the second stop bit is 0, it is treated as the start bit of the next transmit frame.

Bit	Bit Name	Initial Value	R/W	Description
2	MP	0	R/W	Multiprocessor Mode (enabled only in asynchronous mode) When this bit is set to 1, the multiprocessor communication function is enabled. The PE bit and O/ \bar{E} bit settings are invalid in multiprocessor mode.
1	CKS1	0	R/W	Clock Select 1,0
0	CKS0	0	R/W	These bits select the clock source for the on-chip baud rate generator. 00: ϕ clock (n = 0) 01: $\phi/4$ clock (n = 1) 10: $\phi/16$ clock (n = 2) 11: $\phi/64$ clock (n = 3) For the relation between the bit rate register setting and the baud rate, see section 12.3.9, Bit Rate Register (BRR). n is the decimal display of the value of n in BRR.

12.3.6 Serial Control Register (SCR)

SCR is a register that performs enabling or disabling of SCI transfer operations and interrupt requests, and selection of the transfer clock source. For details on interrupt requests, refer to section 12.7, Interrupt Sources.

Bit	Bit Name	Initial Value	R/W	Description
7	TIE	0	R/W	Transmit Interrupt Enable When this bit is set to 1, a TXI interrupt request is enabled.
6	RIE	0	R/W	Receive Interrupt Enable When this bit is set to 1, RXI and ERI interrupt requests are enabled.
5	TE	0	R/W	Transmit Enable When this bit is set to 1, transmission is enabled.
4	RE	0	R/W	Receive Enable When this bit is set to 1, reception is enabled.

Bit	Bit Name	Initial Value	R/W	Description
3	MPIE	0	R/W	<p>Multiprocessor Interrupt Enable (enabled only when the MP bit in SMR is 1 in asynchronous mode)</p> <p>When this bit is set to 1, receive data in which the multiprocessor bit is 0 is skipped, and setting of the RDRF, FER, and ORER status flags in SSR is disabled. On receiving data in which the multiprocessor bit is 1, this bit is automatically cleared and normal reception is resumed. For details, refer to section 12.5, Multiprocessor Communication Function.</p>
2	TEIE	0	R/W	<p>Transmit End Interrupt Enable</p> <p>When this bit is set to 1, a TEI interrupt request is enabled.</p>
1	CKE1	0	R/W	Clock Enable 1, 0
0	CKE0	0	R/W	<p>These bits select the clock source and SCK pin function.</p> <p>Asynchronous mode</p> <p>00: Internal clock (SCK pin functions as I/O port.)</p> <p>01: Internal clock (Outputs a clock of the same frequency as the bit rate from the SCK pin.)</p> <p>1X: External clock (Inputs a clock with a frequency 16 times the bit rate from the SCK pin.)</p> <p>Clocked synchronous mode</p> <p>0X: Internal clock (SCK pin functions as clock output.)</p> <p>1X: External clock (SCK pin functions as clock input.)</p>

[Legend]

X: Don't care

12.3.7 Serial Status Register (SSR)

SSR is a register containing status flags of the SCI and multiprocessor bits for transfer. TDRE, RDRF, ORER, PER, and FER can only be cleared.

Bit	Bit Name	Initial Value	R/W	Description
7	TDRE	1	R/(W)*	<p>Transmit Data Register Empty</p> <p>Indicates whether TDR contains transmit data.</p> <p>[Setting conditions]</p> <ul style="list-style-type: none">• When the TE bit in SCR is 0• When data is transferred from TDR to TSR and TDR is ready for data write <p>[Clearing conditions]</p> <ul style="list-style-type: none">• When 0 is written to TDRE after reading TDRE = 1
6	RDRF	0	R/(W)*	<p>Receive Data Register Full</p> <p>Indicates that receive data is stored in RDR.</p> <p>[Setting condition]</p> <ul style="list-style-type: none">• When serial reception ends normally and receive data is transferred from RSR to RDR <p>[Clearing conditions]</p> <ul style="list-style-type: none">• When 0 is written to RDRF after reading RDRF = 1 <p>The RDRF flag is not affected and retains its previous value when the RE bit in SCR is cleared to 0.</p>
5	ORER	0	R/(W)*	<p>Overrun Error</p> <p>[Setting condition]</p> <ul style="list-style-type: none">• When the next data is received while RDRF = 1 <p>[Clearing condition]</p> <ul style="list-style-type: none">• When 0 is written to ORER after reading ORER = 1
4	FER	0	R/(W)*	<p>Framing Error</p> <p>[Setting condition]</p> <ul style="list-style-type: none">• When the stop bit is 0 <p>[Clearing condition]</p> <ul style="list-style-type: none">• When 0 is written to FER after reading FER = 1 <p>In 2-stop-bit mode, only the first stop bit is checked.</p>

Bit	Bit Name	Initial Value	R/W	Description
3	PER	0	R/(W)*	Parity Error [Setting condition] <ul style="list-style-type: none"> When a parity error is detected during reception [Clearing condition] <ul style="list-style-type: none"> When 0 is written to PER after reading PER = 1
2	TEND	1	R	Transmit End [Setting conditions] <ul style="list-style-type: none"> When the TE bit in SCR is 0 When TDRE = 1 at transmission of the last bit of a 1-byte serial transmit character [Clearing conditions] <ul style="list-style-type: none"> When 0 is written to TDRE after reading TDRE = 1
1	MPB	0	R	Multiprocessor Bit MPB stores the multiprocessor bit in the receive frame. When the RE bit in SCR is cleared to 0 its previous state is retained.
0	MPBT	0	R/W	Multiprocessor Bit Transfer MPBT stores the multiprocessor bit to be added to the transmit frame.

Note: * Only 0 can be written, to clear the flag.

12.3.8 Serial Interface Mode Register (SCMR)

SCMR selects SCI functions and its format.

Bit	Bit Name	Initial Value	R/W	Description
7 to 4	—	All 1	R	Reserved These bits are always read as 1 and cannot be modified.
3	SDIR	0	R/W	Data Transfer Direction Selects the serial/parallel conversion format. 0: TDR contents are transmitted with LSB-first. Receive data is stored as LSB first in RDR. 1: TDR contents are transmitted with MSB-first. Receive data is stored as MSB first in RDR. The SDIR bit is valid only when the 8-bit data format is used for transmission/reception; when the 7-bit data format is used, data is always transmitted/received with LSB-first.
2	SINV	0	R/W	Data Invert Specifies inversion of the data logic level. The SINV bit does not affect the logic level of the parity bit. When the parity bit is inverted, invert the O/E bit in SMR. 0: TDR contents are transmitted as they are. Receive data is stored as it is in RDR. 1: TDR contents are inverted before being transmitted. Receive data is stored in inverted form in RDR.
1	—	1	R	Reserved This bit is always read as 1 and cannot be modified.
0	SMIF	0	R/W	Serial Communication Interface Mode Select: 0: Normal asynchronous or clocked synchronous mode 1: Reserved mode

12.3.9 Bit Rate Register (BRR)

BRR is an 8-bit register that adjusts the bit rate. As the SCI performs baud rate generator control independently for each channel, different bit rates can be set for each channel. Table 12.2 shows the relationships between the N setting in BRR and bit rate B for normal asynchronous mode and clocked synchronous mode. The initial value of BRR is H'FF, and it can be read from or written to by the CPU at all times.

Table 12.2 Relationships between N Setting in BRR and Bit Rate B

Mode	Bit Rate	Error
Asynchronous mode	$B = \frac{\phi \times 10^6}{64 \times 2^{2n-1} \times (N + 1)}$	$\text{Error (\%)} = \left\{ \frac{\phi \times 10^6}{B \times 64 \times 2^{2n-1} \times (N + 1)} - 1 \right\} \times 100$
Clocked synchronous mode	$B = \frac{\phi \times 10^6}{64 \times 2^{2n-1} \times (N + 1)}$	—

[Legend]

B: Bit rate (bit/s)

N: BRR setting for baud rate generator ($0 \leq N \leq 255$)

ϕ : Operating frequency (MHz)

n: Determined by the SMR settings shown in the following table.

SMR Setting		
CKS1	CKS0	n
0	0	0
0	1	1
1	0	2
1	1	3

Table 12.3 shows sample N settings in BRR in normal asynchronous mode. Table 12.4 shows the maximum bit rate settable for each frequency. Table 12.6 shows sample N settings in BRR in clocked synchronous mode. Tables 12.5 and 12.7 show the maximum bit rates with external clock input.

Table 12.3 BRR Settings for Various Bit Rates (Asynchronous Mode) (1)

Bit Rate (bit/s)	Operating Frequency ϕ (MHz)								
	4			4.9152			5		
	n	N	Error (%)	n	N	Error (%)	n	N	Error (%)
110	2	70	0.03	2	86	0.31	2	88	-0.25
150	1	207	0.16	1	255	0.00	2	64	0.16
300	1	103	0.16	1	127	0.00	1	129	0.16
600	0	207	0.16	0	255	0.00	1	64	0.16
1200	0	103	0.16	0	127	0.00	0	129	0.16
2400	0	51	0.16	0	63	0.00	0	64	0.16
4800	0	25	0.16	0	31	0.00	0	32	-1.36
9600	0	12	0.16	0	15	0.00	0	15	1.73
19200	—	—	—	0	7	0.00	0	7	1.73
31250	0	3	0.00	0	4	-1.70	0	4	0.00
38400	—	—	—	0	3	0.00	0	3	1.73

[Legend]

—: Can be set, but there will be a degree of error.

Note: * Make the settings so that the error does not exceed 1%.

Table 12.3 BRR Settings for Various Bit Rates (Asynchronous Mode) (2)

Bit Rate (bit/s)	Operating Frequency ϕ (MHz)											
	6			6.144			7.3728			8		
	n	N	Error (%)	n	N	Error (%)	n	N	Error (%)	n	N	Error (%)
110	2	106	-0.44	2	108	0.08	2	130	-0.07	2	141	0.03
150	2	77	0.16	2	79	0.00	2	95	0.00	2	103	0.16
300	1	155	0.16	1	159	0.00	1	191	0.00	1	207	0.16
600	1	77	0.16	1	79	0.00	1	95	0.00	1	103	0.16
1200	0	155	0.16	0	159	0.00	0	191	0.00	0	207	0.16
2400	0	77	0.16	0	79	0.00	0	95	0.00	0	103	0.16
4800	0	38	0.16	0	39	0.00	0	47	0.00	0	51	0.16
9600	0	19	-2.34	0	19	0.00	0	23	0.00	0	25	0.16
19200	0	9	-2.34	0	9	0.00	0	11	0.00	0	12	0.16
31250	0	5	0.00	0	5	2.40	—	—	—	0	7	0.00
38400	0	4	-2.34	0	4	0.00	0	5	0.00	—	—	—

Bit Rate (bit/s)	Operating Frequency ϕ (MHz)					
	9.8304			10		
	n	N	Error (%)	n	N	Error (%)
110	2	174	-0.26	2	177	-0.25
150	2	127	0.00	2	129	0.16
300	1	255	0.00	2	64	0.16
600	1	127	0.00	1	129	0.16
1200	0	255	0.00	1	64	0.16
2400	0	127	0.00	0	129	0.16
4800	0	63	0.00	0	64	0.16
9600	0	31	0.00	0	32	-1.36
19200	0	15	0.00	0	15	1.73
31250	0	9	-1.70	0	9	0.00
38400	0	7	0.00	0	7	1.73

[Legend]

—: Can be set, but there will be a degree of error.

Note: * Make the settings so that the error does not exceed 1%.

Table 12.4 Maximum Bit Rate for Each Frequency (Asynchronous Mode)

ϕ (MHz)	Maximum Bit Rate (bit/s)	n	N	ϕ (MHz)	Maximum Bit Rate (bit/s)	n	N
4	125000	0	0	9.8304	307200	0	0
4.9152	153600	0	0	10	312500	0	0
5	156250	0	0				
6	187500	0	0				
6.144	192000	0	0				
7.3728	230400	0	0				
8	250000	0	0				

Table 12.5 Maximum Bit Rate with External Clock Input (Asynchronous Mode)

ϕ (MHz)	External Input Clock (MHz)	Maximum Bit Rate (bit/s)	ϕ (MHz)	External Input Clock (MHz)	Maximum Bit Rate (bit/s)
4	1.0000	62500	9.8304	2.4576	153600
4.9152	1.2288	76800	10	2.5000	156250
5	1.2500	78125			
6	15.000	93750			
6.144	1.5360	96000			
7.3728	1.8432	115200			
8	2.0000	125000			

Table 12.6 BRR Settings for Various Bit Rates (Clocked Synchronous Mode)

Bit Rate (bit/s)	Operating Frequency ϕ (MHz)					
	4		8		10	
	n	N	n	N	n	N
110	—	—				
250	2	249	3	124	—	—
500	2	124	2	249	—	—
1k	1	249	2	124	—	—
2.5k	1	99	1	199	1	249
5k	0	199	1	99	1	124
10k	0	99	0	199	0	249
25k	0	39	0	79	0	99
50k	0	19	0	39	0	49
100k	0	9	0	19	0	24
250k	0	3	0	7	0	9
500k	0	1*	0	3	0	4
1M	0	0	0	1		
2.5M					0	0*
5M						

[Legend]

Blank: Cannot be set.

—: Can be set, but there will be a degree of error.

*: Continuous transfer or reception is not possible.

Table 12.7 Maximum Bit Rate with External Clock Input (Clocked Synchronous Mode)

ϕ (MHz)	External Input Clock (MHz)	Maximum Bit Rate (bit/s)
4	0.6667	666666.7
6	1.0000	1000000.0
8	1.3333	1333333.3
10	1.6667	1666666.7

12.3.10 Serial Pin Select Register (SPSR)

SPSR selects the serial I/O pins. SPSR should be set before initialization. Do not set during communication.

Bit	Bit Name	Initial Value	R/W	Description
7	SPS1	0	R/W	Serial Port Select Selects the serial I/O pins. 0: P86/SCK1, P85/RxD1, P84/TxD1 1: P52/ExSCK1, P51/ExRxD1, P50/ExTxD1
6 to 0	—	All 0	R/W	Reserved The initial value should not be changed.

Note: The program development tool (emulator) does not support SPSR.

12.4 Operation in Asynchronous Mode

Figure 12.2 shows the general format for asynchronous serial communication. One frame consists of a start bit (low level), followed by transmit/receive data, a parity bit, and finally stop bits (high level). In asynchronous serial communication, the transmission line is usually held in the mark state (high level). The SCI monitors the transmission line, and when it goes to the space state (low level), recognizes a start bit and starts serial communication. Inside the SCI, the transmitter and receiver are independent units, enabling full-duplex communication. Both the transmitter and the receiver also have a double-buffered structure, so that data can be read or written during transmission or reception, enabling continuous data transfer and reception.

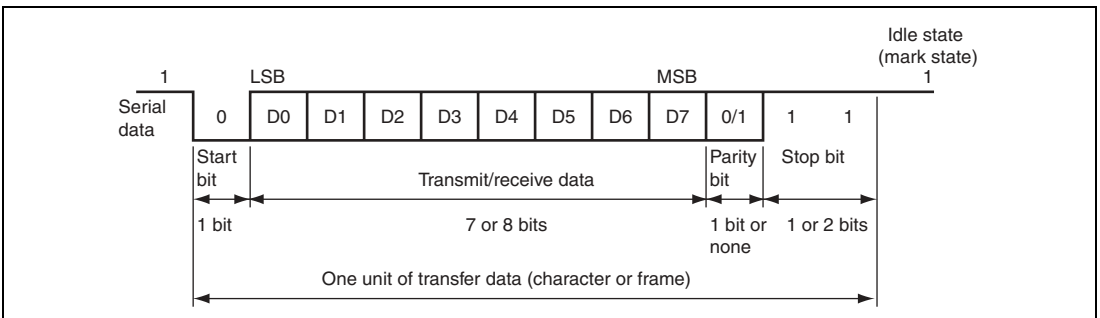

**Figure 12.2 Data Format in Asynchronous Communication
(Example with 8-Bit Data, Parity, Two Stop Bits)**

12.4.1 Data Transfer Format

Table 12.8 shows the data transfer formats that can be used in asynchronous mode. Any of 12 transfer formats can be selected according to the SMR setting. For details on the multiprocessor bit, refer to section 12.5, Multiprocessor Communication Function.

Table 12.8 Serial Transfer Formats (Asynchronous Mode)

SMR Settings				Serial Transmit/Receive Format and Frame Length														
CHR	PE	MP	STOP	1	2	3	4	5	6	7	8	9	10	11	12			
0	0	0	0	S	8-bit data								STOP					
0	0	0	1	S	8-bit data								STOP	STOP				
0	1	0	0	S	8-bit data								P	STOP				
0	1	0	1	S	8-bit data								P	STOP	STOP			
1	0	0	0	S	7-bit data							STOP						
1	0	0	1	S	7-bit data							STOP	STOP					
1	1	0	0	S	7-bit data							P	STOP					
1	1	0	1	S	7-bit data							P	STOP	STOP				
0	—	1	0	S	8-bit data								MPB	STOP				
0	—	1	1	S	8-bit data								MPB	STOP	STOP			
1	—	1	0	S	7-bit data							MPB	STOP					
1	—	1	1	S	7-bit data							MPB	STOP	STOP				

12.4.2 Receive Data Sampling Timing and Reception Margin in Asynchronous Mode

In asynchronous mode, the SCI operates on a basic clock with a frequency of 16 times the bit rate. In reception, the SCI samples the falling edge of the start bit using the basic clock, and performs internal synchronization. Since receive data is latched internally at the rising edge of the 8th pulse of the basic clock, data is latched at the middle of each bit, as shown in figure 12.3. Thus the reception margin in asynchronous mode is determined by formula (1) below.

$$M = \left\{ \left(0.5 - \frac{1}{2N} \right) - \frac{D - 0.5}{N} (1 + F) - (L - 0.5) F \right\} \times 100 \quad [\%] \quad \dots \quad \text{Formula (1)}$$

[Legend]

- M: Reception margin (%)
- N : Ratio of bit rate to clock (N = 16)
- D : Clock duty (D = 0.5 to 1.0)
- L : Frame length (L = 9 to 12)
- F : Absolute value of clock rate deviation

Assuming values of F = 0 and D = 0.5 in formula (1), the reception margin is determined by the formula below.

$$M = \{0.5 - 1/(2 \times 16)\} \times 100 \quad [\%] = 46.875 \%$$

However, this is only the computed value, and a margin of 20% to 30% should be allowed in system design.

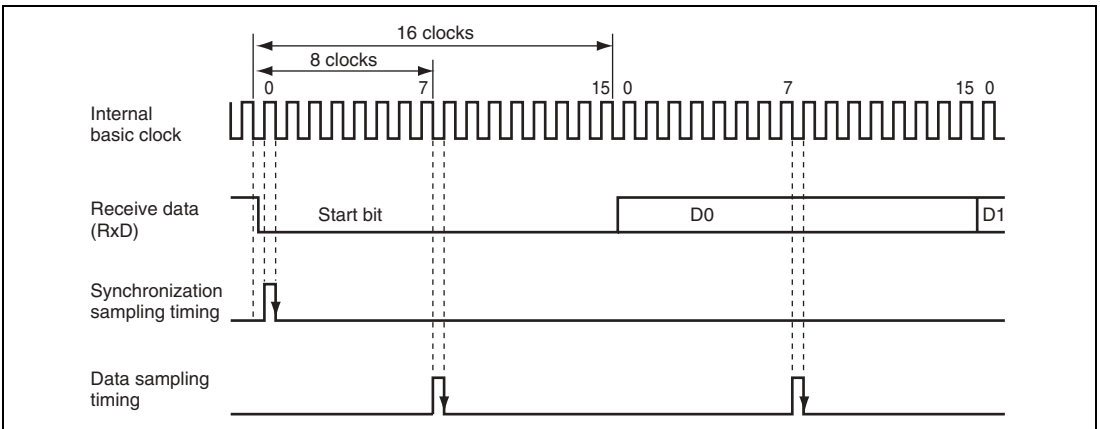

Figure 12.3 Receive Data Sampling Timing in Asynchronous Mode

12.4.3 Clock

Either an internal clock generated by the on-chip baud rate generator or an external clock input at the SCK pin can be selected as the SCI's transfer clock, according to the setting of the C/\bar{A} bit in SMR and the CKE1 and CKE0 bits in SCR. When an external clock is input at the SCK pin, the clock frequency should be 16 times the bit rate used.

When the SCI is operated on an internal clock, the clock can be output from the SCK pin. The frequency of the clock output in this case is equal to the bit rate, and the phase is such that the rising edge of the clock is in the middle of the transmit data, as shown in figure 12.4.

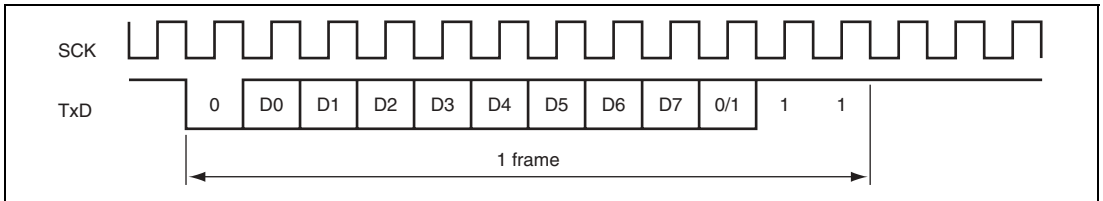

Figure 12.4 Relation between Output Clock and Transmit Data Phase (Asynchronous Mode)

12.4.4 SCI Initialization (Asynchronous Mode)

Before transmitting and receiving data, you should first clear the TE and RE bits in SCR to 0, then initialize the SCI as shown in figure 12.5. When the operating mode, transfer format, etc., is changed, the TE and RE bits must be cleared to 0 before making the change using the following procedure. When the TE bit is cleared to 0, the TDRE flag in SSR is set to 1. Note that clearing the RE bit to 0 does not initialize the contents of the RDRF, PER, FER, and ORER flags in SSR, or the contents of RDR. When an external clock is used in asynchronous mode, the clock must be supplied even during initialization.

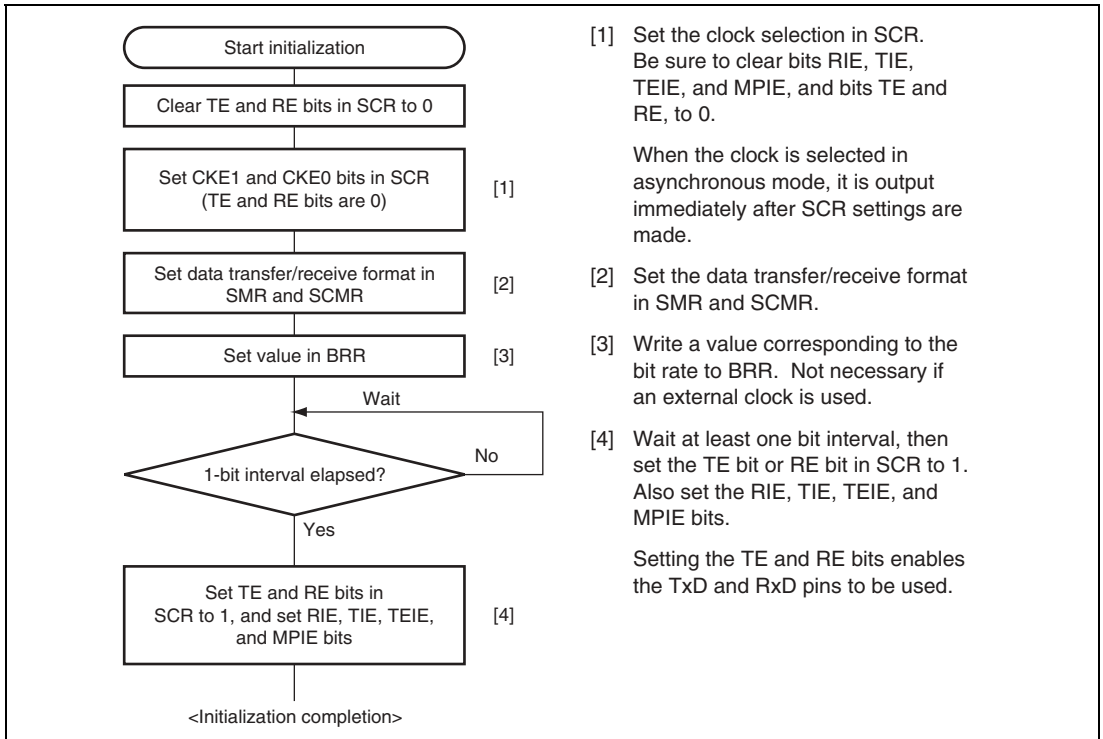

Figure 12.5 Sample SCI Initialization Flowchart

12.4.5 Data Transmission (Asynchronous Mode)

Figure 12.6 shows an example of the operation for transmission in asynchronous mode. In transmission, the SCI operates as described below.

1. The SCI monitors the TDRE flag in SSR, and if it is cleared to 0, recognizes that data has been written to TDR, and transfers the data from TDR to TSR.
2. After transferring data from TDR to TSR, the SCI sets the TDRE flag to 1 and starts transmission. If the TIE bit in SCR is set to 1 at this time, a transmit data empty interrupt request (TXI) is generated. Because the TXI interrupt routine writes the next transmit data to TDR before transmission of the current transmit data has finished, continuous transmission can be enabled.
3. Data is sent from the TxD pin in the following order: start bit, transmit data, parity bit or multiprocessor bit (may be omitted depending on the format), and stop bit.
4. The SCI checks the TDRE flag at the timing for sending the stop bit.
5. If the TDRE flag is 0, the data is transferred from TDR to TSR, the stop bit is sent, and then serial transmission of the next frame is started.
6. If the TDRE flag is 1, the TEND flag in SSR is set to 1, the stop bit is sent, and then the “mark state” is entered in which 1 is output. If the TEIE bit in SCR is set to 1 at this time, a TEI interrupt request is generated.

Figure 12.7 shows a sample flowchart for transmission in asynchronous mode.

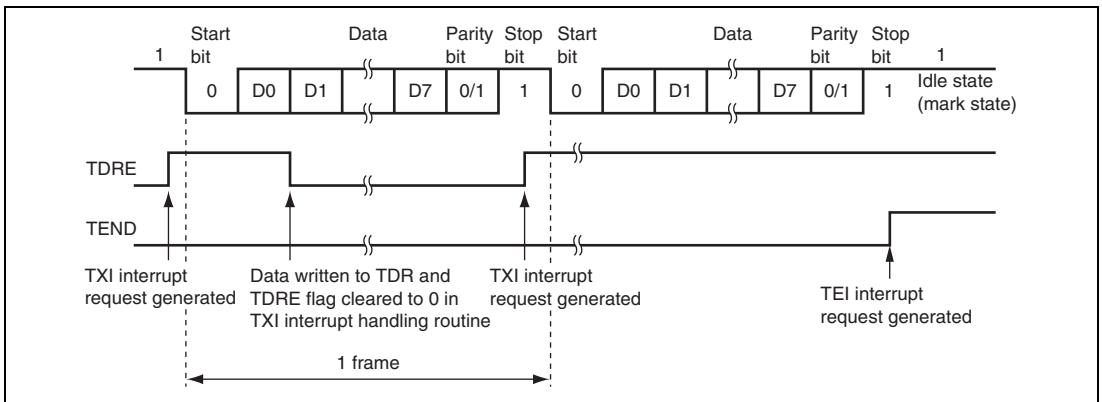
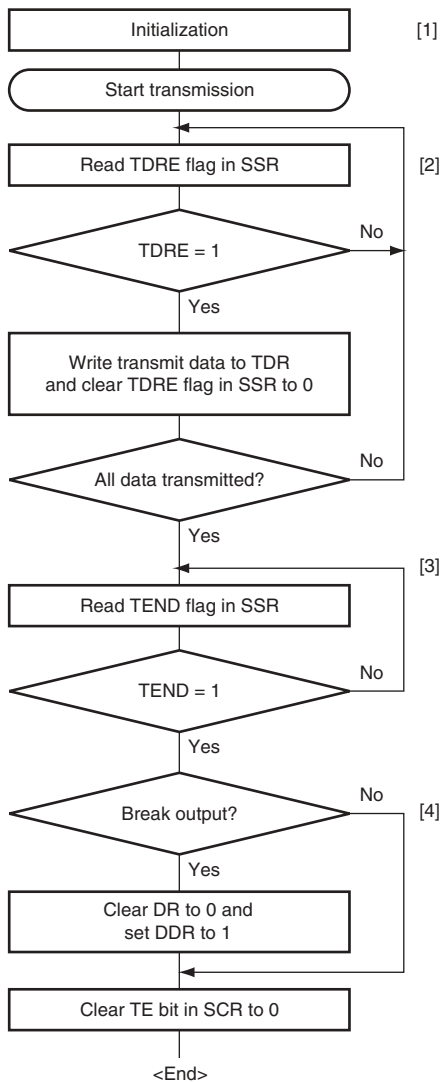

Figure 12.6 Example of SCI Transmit Operation in Asynchronous Mode (Example with 8-Bit Data, Parity, One Stop Bit)



- [1] SCI initialization:
The TxD pin is automatically designated as the transmit data output pin.
After the TE bit is set to 1, a frame of 1s is output, and transmission is enabled.
- [2] SCI status check and transmit data write:
Read SSR and check that the TDRE flag is set to 1, then write transmit data to TDR and clear the TDRE flag to 0.
- [3] Serial transmission continuation procedure:
To continue serial transmission, read 1 from the TDRE flag to confirm that writing is possible, then write data to TDR, and clear the TDRE flag to 0.
- [4] Break output at the end of serial transmission:
To output a break in serial transmission, set DDR for the port corresponding to the TxD pin to 1, clear DR to 0, then clear the TE bit in SCR to 0.

Figure 12.7 Sample Serial Transmission Flowchart

12.4.6 Serial Data Reception (Asynchronous Mode)

Figure 12.8 shows an example of the operation for reception in asynchronous mode. In serial reception, the SCI operates as described below.

1. The SCI monitors the communication line, and if a start bit is detected, performs internal synchronization, receives receive data in RSR, and checks the parity bit and stop bit.
2. If an overrun error (when reception of the next data is completed while the RDRF flag in SSR is still set to 1) occurs, the ORER bit in SSR is set to 1. If the RIE bit in SCR is set to 1 at this time, an ERI interrupt request is generated. Receive data is not transferred to RDR. The RDRF flag remains to be set to 1.
3. If a parity error is detected, the PER bit in SSR is set to 1 and receive data is transferred to RDR. If the RIE bit in SCR is set to 1 at this time, an ERI interrupt request is generated.
4. If a framing error (when the stop bit is 0) is detected, the FER bit in SSR is set to 1 and receive data is transferred to RDR. If the RIE bit in SCR is set to 1 at this time, an ERI interrupt request is generated.
5. If reception finishes successfully, the RDRF bit in SSR is set to 1, and receive data is transferred to RDR. If the RIE bit in SCR is set to 1 at this time, an RXI interrupt request is generated. Because the RXI interrupt routine reads the receive data transferred to RDR before reception of the next receive data has finished, continuous reception can be enabled.

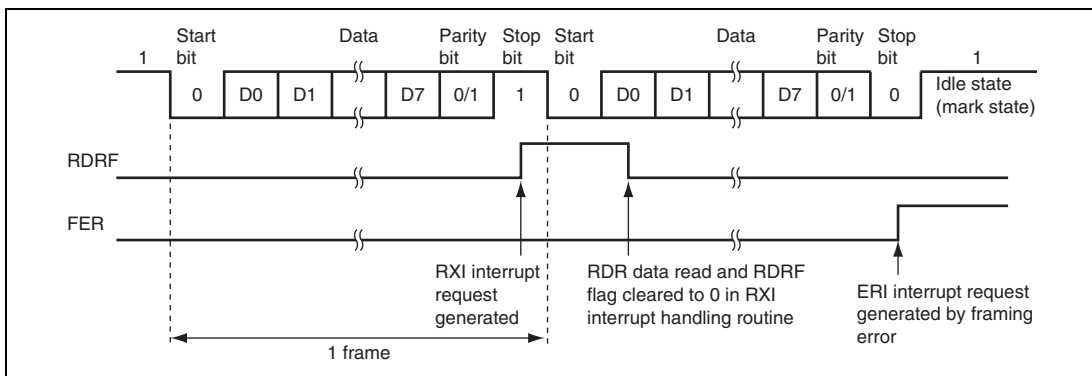

**Figure 12.8 Example of SCI Receive Operation in Asynchronous Mode
(Example with 8-Bit Data, Parity, One Stop Bit)**

Table 12.9 shows the states of the SSR status flags and receive data handling when a receive error is detected. If a receive error is detected, the RDRF flag retains its state before receiving data. Reception cannot be resumed while a receive error flag is set to 1. Accordingly, clear the ORER, FER, PER, and RDRF bits to 0 before resuming reception. Figure 12.9 shows a sample flow chart for serial data reception.

Table 12.9 SSR Status Flags and Receive Data Handling

SSR Status Flag				Receive Data	Receive Error Type
RDRF*	ORER	FER	PER		
1	1	0	0	Lost	Overrun error
0	0	1	0	Transferred to RDR	Framing error
0	0	0	1	Transferred to RDR	Parity error
1	1	1	0	Lost	Overrun error + framing error
1	1	0	1	Lost	Overrun error + parity error
0	0	1	1	Transferred to RDR	Framing error + parity error
1	1	1	1	Lost	Overrun error + framing error + parity error

Note: * The RDRF flag retains the state it had before data reception.

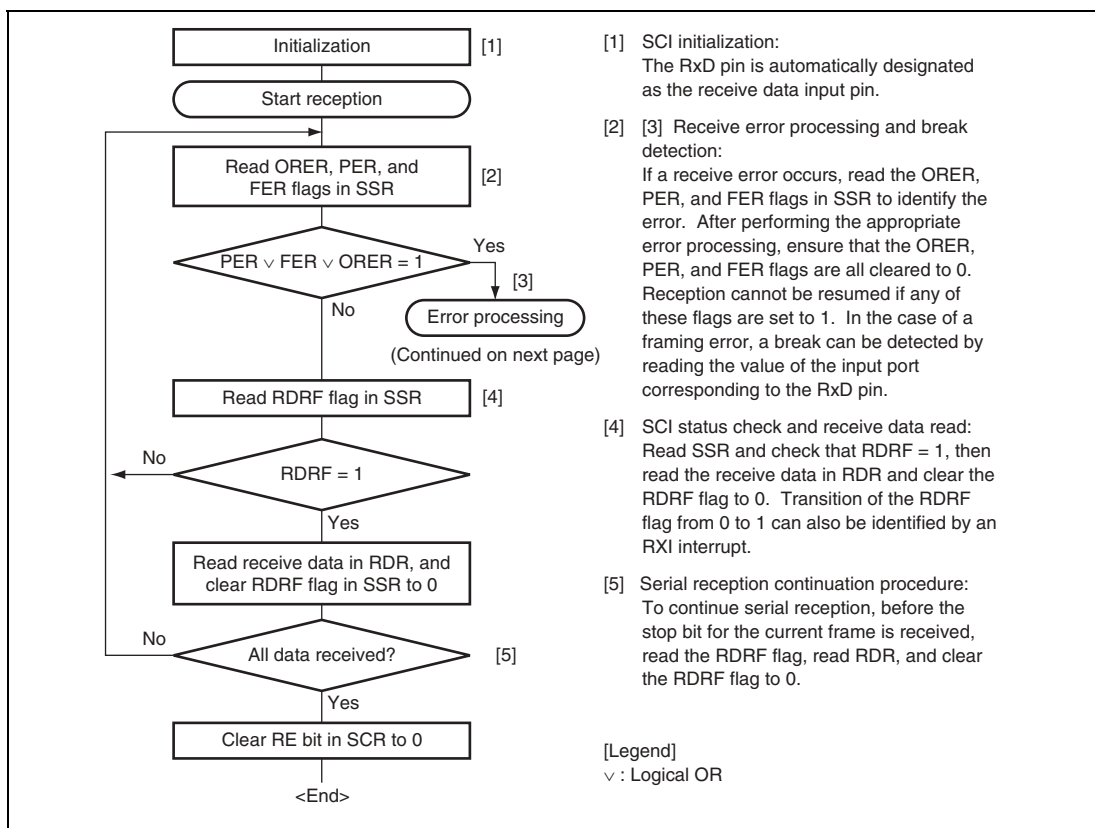

Figure 12.9 Sample Serial Reception Flowchart (1)

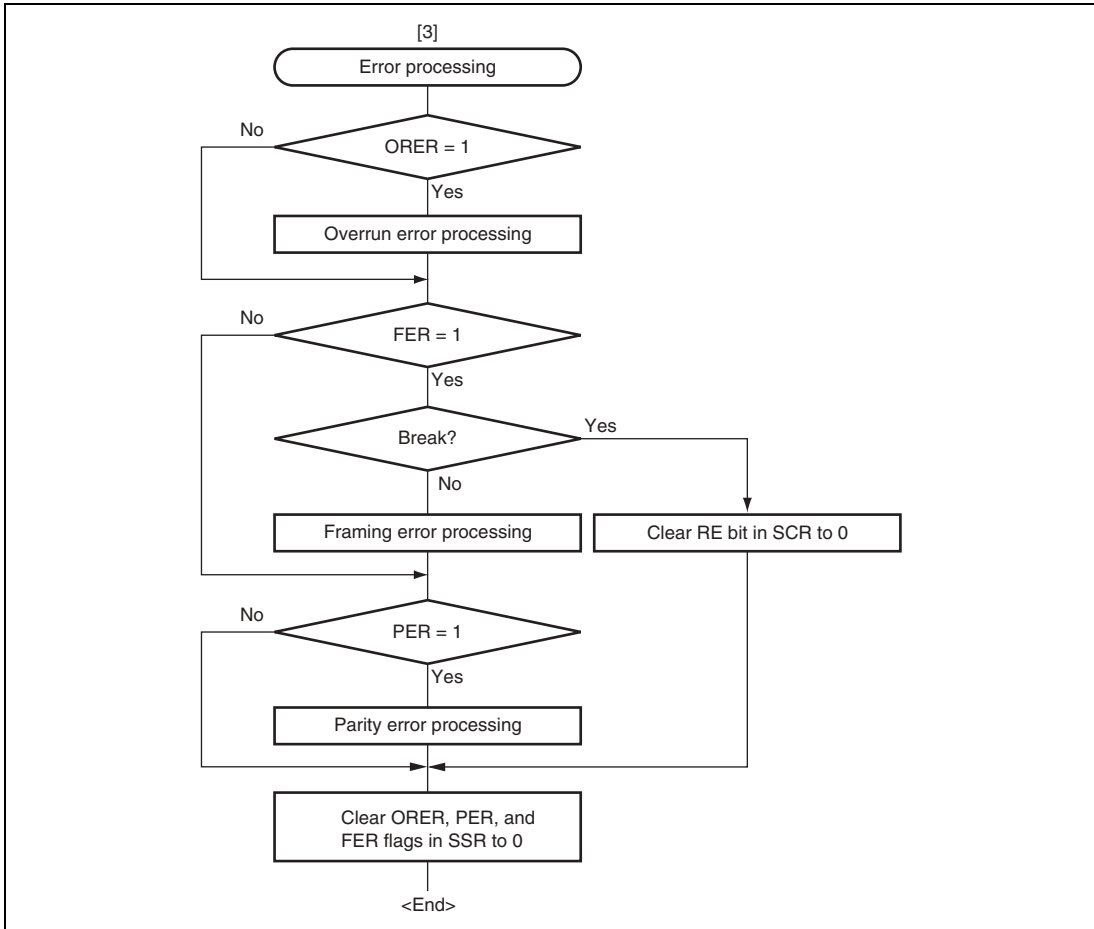

Figure 12.9 Sample Serial Reception Flowchart (2)

12.5 Multiprocessor Communication Function

Use of the multiprocessor communication function enables data transfer to be performed among a number of processors sharing communication lines by means of asynchronous serial communication using the multiprocessor format, in which a multiprocessor bit is added to the transfer data. When multiprocessor communication is carried out, each receiving station is addressed by a unique ID code. The serial communication cycle consists of two component cycles: an ID transmission cycle which specifies the receiving station, and a data transmission cycle for the specified receiving station. The multiprocessor bit is used to differentiate between the ID transmission cycle and the data transmission cycle. If the multiprocessor bit is 1, the cycle is an ID transmission cycle, and if the multiprocessor bit is 0, the cycle is a data transmission cycle. Figure 12.10 shows an example of inter-processor communication using the multiprocessor format. The transmitting station first sends the ID code of the receiving station with which it wants to perform serial communication as data with a 1 multiprocessor bit added. It then sends transmit data as data with a 0 multiprocessor bit added. The receiving station skips data until data with a 1 multiprocessor bit is sent. When data with a 1 multiprocessor bit is received, the receiving station compares that data with its own ID. The station whose ID matches then receives the data sent next. Stations whose ID does not match continue to skip data until data with a 1 multiprocessor bit is again received.

The SCI uses the MPIE bit in SCR to implement this function. When the MPIE bit is set to 1, transfer of receive data from RSR to RDR, error flag detection, and setting the SSR status flags, RDRF, FER, and ORER in SSR to 1 are prohibited until data with a 1 multiprocessor bit is received. On reception of a receive character with a 1 multiprocessor bit, the MPB bit in SSR is set to 1 and the MPIE bit is automatically cleared, thus normal reception is resumed. If the RIE bit in SCR is set to 1 at this time, an RXI interrupt is generated.

When the multiprocessor format is selected, the parity bit setting is invalid. All other bit settings are the same as those in normal asynchronous mode. The clock used for multiprocessor communication is the same as that in normal asynchronous mode.

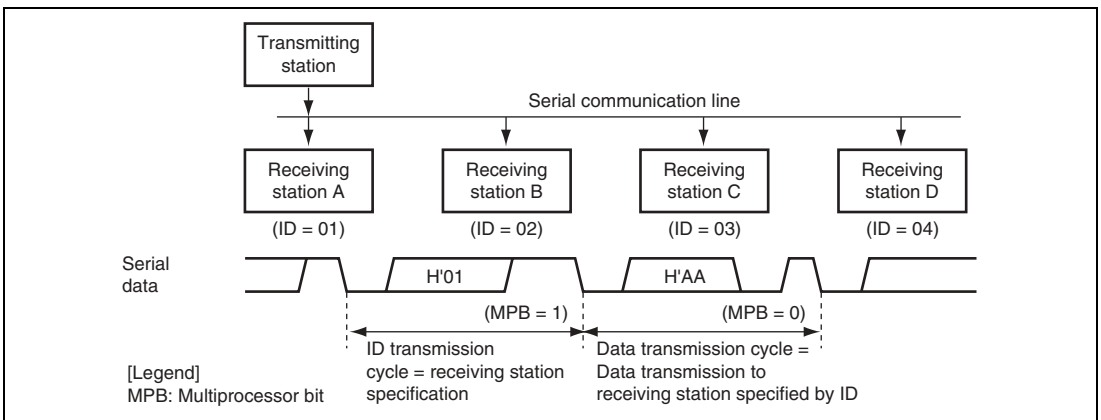

Figure 12.10 Example of Communication Using Multiprocessor Format (Transmission of Data H'AA to Receiving Station A)

12.5.1 Multiprocessor Serial Data Transmission

Figure 12.11 shows a sample flowchart for multiprocessor serial data transmission. For an ID transmission cycle, set the MPBT bit in SSR to 1 before transmission. For a data transmission cycle, clear the MPBT bit in SSR to 0 before transmission. All other SCI operations are the same as those in asynchronous mode.

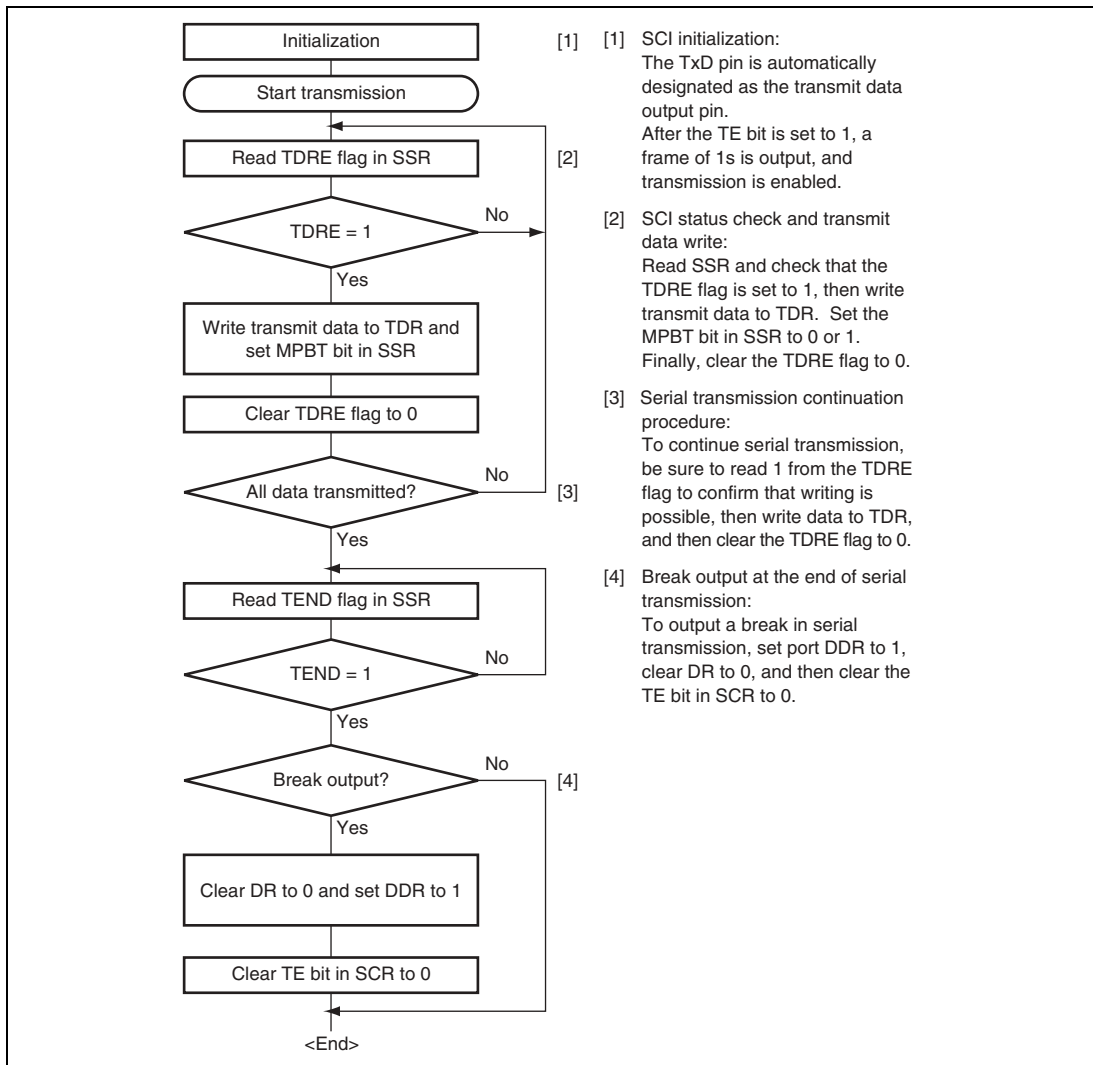

Figure 12.11 Sample Multiprocessor Serial Transmission Flowchart

12.5.2 Multiprocessor Serial Data Reception

Figure 12.13 shows a sample flowchart for multiprocessor serial data reception. If the MPIE bit in SCR is set to 1, data is skipped until data with a 1 multiprocessor bit is sent. On receiving data with a 1 multiprocessor bit, the receive data is transferred to RDR. An RXI interrupt request is generated at this time. All other SCI operations are the same as in asynchronous mode. Figure 12.12 shows an example of SCI operation for multiprocessor format reception.

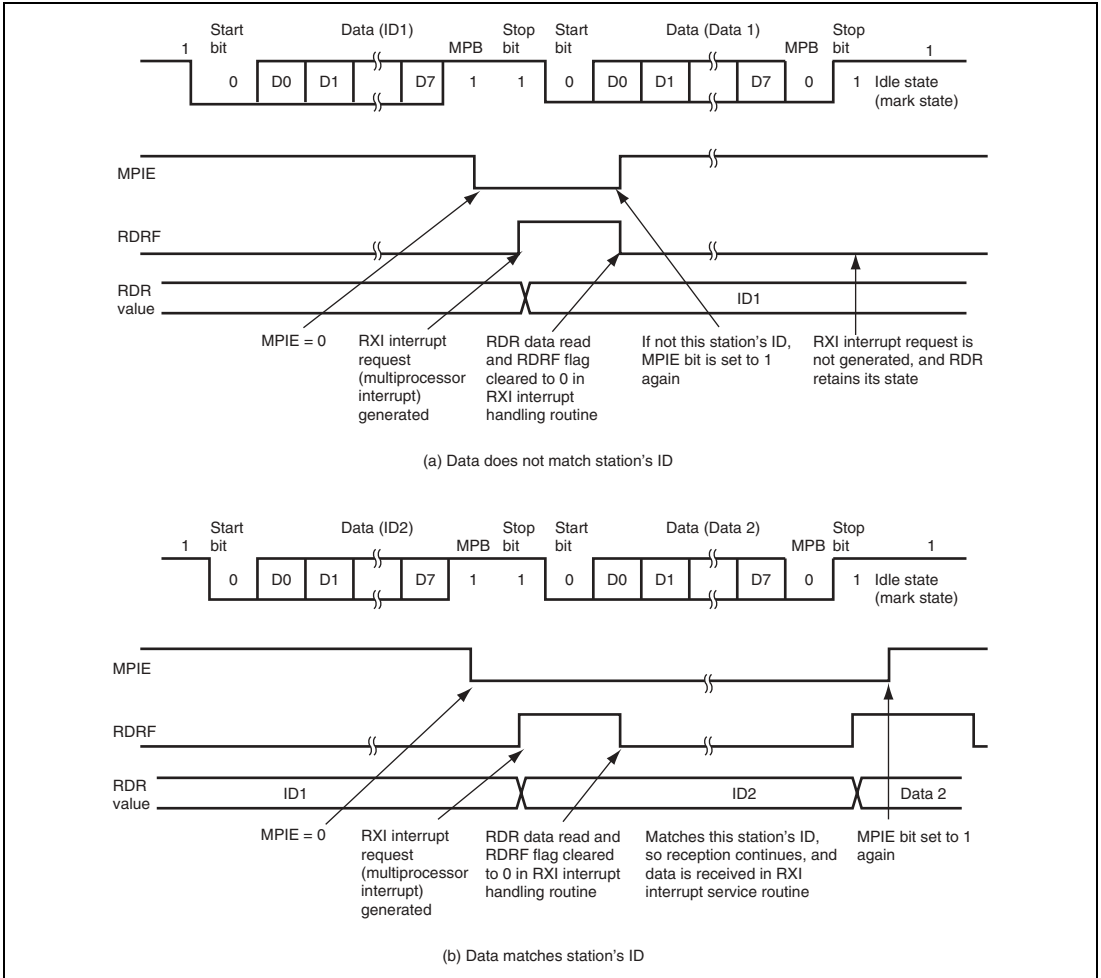
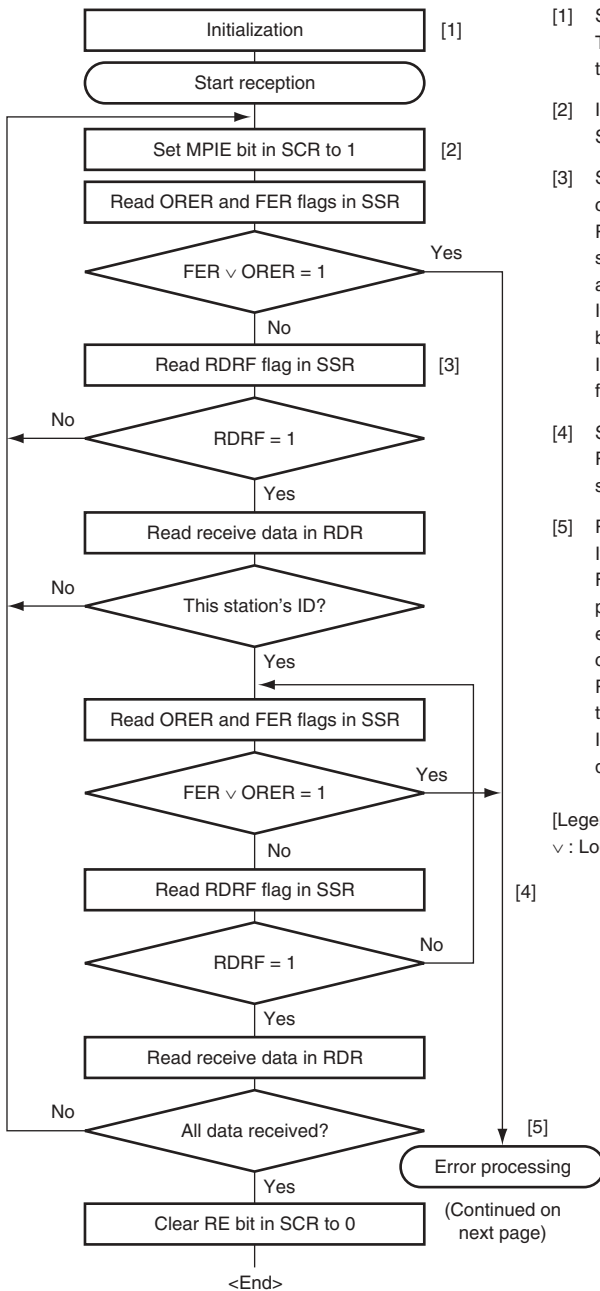

Figure 12.12 Example of SCI Receive Operation (Example with 8-Bit Data, Multiprocessor Bit, One Stop Bit)



- [1] SCI initialization:
The RxD pin is automatically designated as the receive data input pin.
- [2] ID reception cycle:
Set the MPIE bit in SCR to 1.
- [3] SCI status check, ID reception and comparison:
Read SSR and check that the RDRF flag is set to 1, then read the receive data in RDR and compare it with this station's ID. If the data is not this station's ID, set the MPIE bit to 1 again, and clear the RDRF flag to 0. If the data is this station's ID, clear the RDRF flag to 0.
- [4] SCI status check and data reception:
Read SSR and check that the RDRF flag is set to 1, then read the data in RDR.
- [5] Receive error processing and break detection:
If a receive error occurs, read the ORER and FER flags in SSR to identify the error. After performing the appropriate error processing, ensure that the ORER and FER flags are all cleared to 0. Reception cannot be resumed if either of these flags is set to 1. In the case of a framing error, a break can be detected by reading the RxD pin value.

[Legend]
v : Logical OR

Figure 12.13 Sample Multiprocessor Serial Reception Flowchart (1)

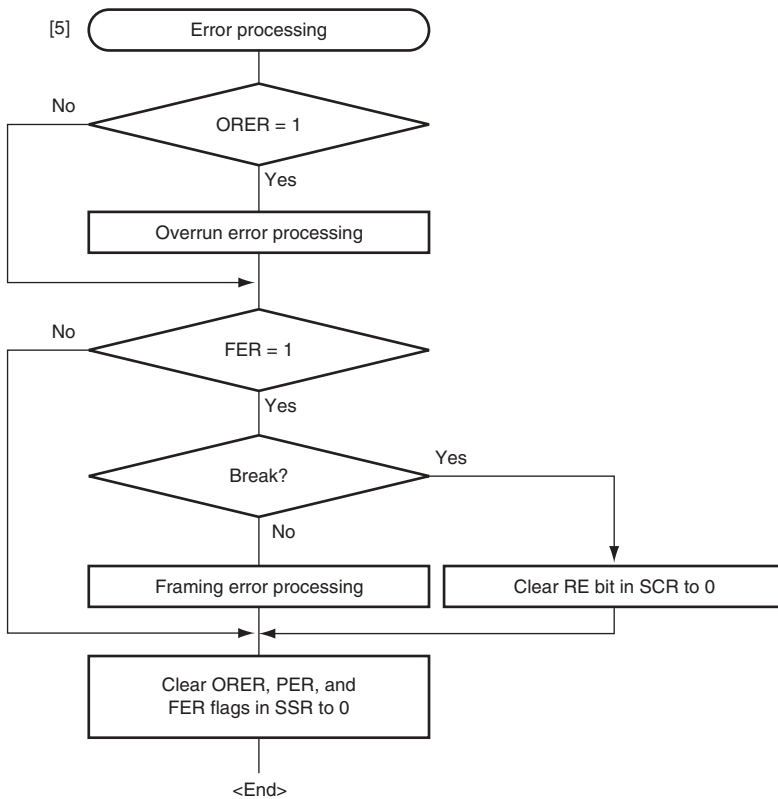

Figure 12.13 Sample Multiprocessor Serial Reception Flowchart (2)

12.6 Operation in Clocked Synchronous Mode

Figure 12.14 shows the general format for clocked synchronous communication. In clocked synchronous mode, data is transmitted or received in synchronization with clock pulses. One character in transfer data consists of 8-bit data. In data transmission, the SCI outputs data from one falling edge of the synchronization clock to the next. In data reception, the SCI receives data in synchronization with the rising edge of the synchronization clock. After 8-bit data is output, the transmission line holds the MSB state. In clocked synchronous mode, no parity or multiprocessor bit is added. Inside the SCI, the transmitter and receiver are independent units, enabling full-duplex communication by use of a common clock. Both the transmitter and the receiver also have a double-buffered structure, so that the next transmit data can be written during transmission or the previous receive data can be read during reception, enabling continuous data transfer.

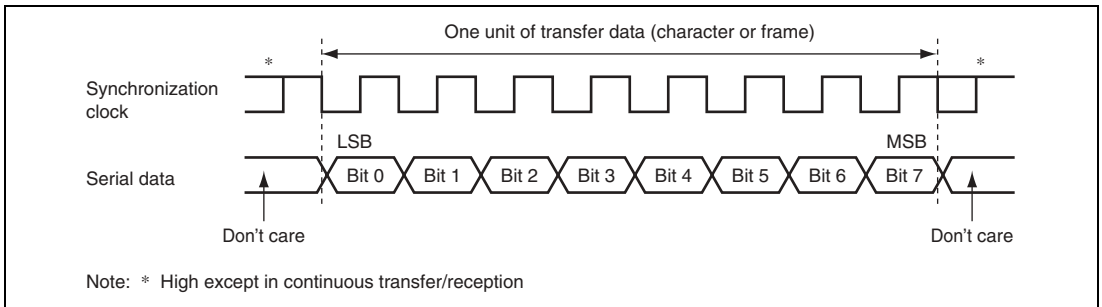

Figure 12.14 Data Format in Clocked Synchronous Communication (LSB-First)

12.6.1 Clock

Either an internal clock generated by the on-chip baud rate generator or an external synchronization clock input at the SCK pin can be selected, according to the setting of the CKE1 and CKE0 bits in SCR. When the SCI is operated on an internal clock, the synchronization clock is output from the SCK pin. Eight synchronization clock pulses are output in the transfer of one character, and when no transfer is performed the clock is fixed high.

12.6.2 SCI Initialization (Clocked Synchronous Mode)

Before transmitting and receiving data, you should first clear the TE and RE bits in SCR to 0, then initialize the SCI as described in a sample flowchart in figure 12.15. When the operating mode, transfer format, etc., is changed, the TE and RE bits must be cleared to 0 before making the change using the following procedure. When the TE bit is cleared to 0, the TDRE flag in SSR is set to 1. However, clearing the RE bit to 0 does not initialize the RDRF, PER, FER, and ORER flags in SSR, or RDR.

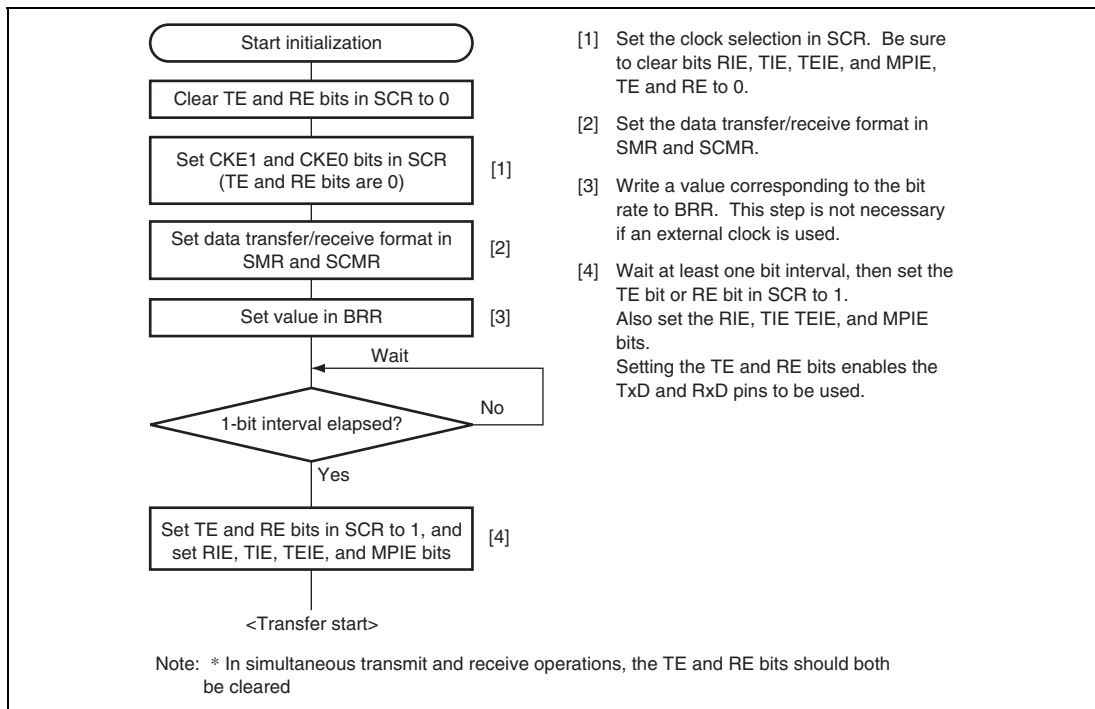

Figure 12.15 Sample SCI Initialization Flowchart

12.6.3 Serial Data Transmission (Clocked Synchronous Mode)

Figure 12.16 shows an example of SCI operation for transmission in clocked synchronous mode. In serial transmission, the SCI operates as described below.

1. The SCI monitors the TDRE flag in SSR, and if it is 0, recognizes that data has been written to TDR, and transfers the data from TDR to TSR.
2. After transferring data from TDR to TSR, the SCI sets the TDRE flag to 1 and starts transmission. If the TIE bit in SCR is set to 1 at this time, a TXI interrupt request is generated. Because the TXI interrupt routine writes the next transmit data to TDR before transmission of the current transmit data has finished, continuous transmission can be enabled.
3. 8-bit data is sent from the TxD pin synchronized with the output clock when output clock mode has been specified and synchronized with the input clock when use of an external clock has been specified.
4. The SCI checks the TDRE flag at the timing for sending the last bit.
5. If the TDRE flag is cleared to 0, data is transferred from TDR to TSR, and serial transmission of the next frame is started.
6. If the TDRE flag is set to 1, the TEND flag in SSR is set to 1, and the TxD pin maintains the output state of the last bit. If the TEIE bit in SCR is set to 1 at this time, a TEI interrupt request is generated. The SCK pin is fixed high.

Figure 12.17 shows a sample flow chart for serial data transmission. Even if the TDRE flag is cleared to 0, transmission will not start while a receive error flag (ORER, FER, or PER) is set to 1. Make sure to clear the receive error flags to 0 before starting transmission. Note that clearing the RE bit to 0 does not clear the receive error flags.

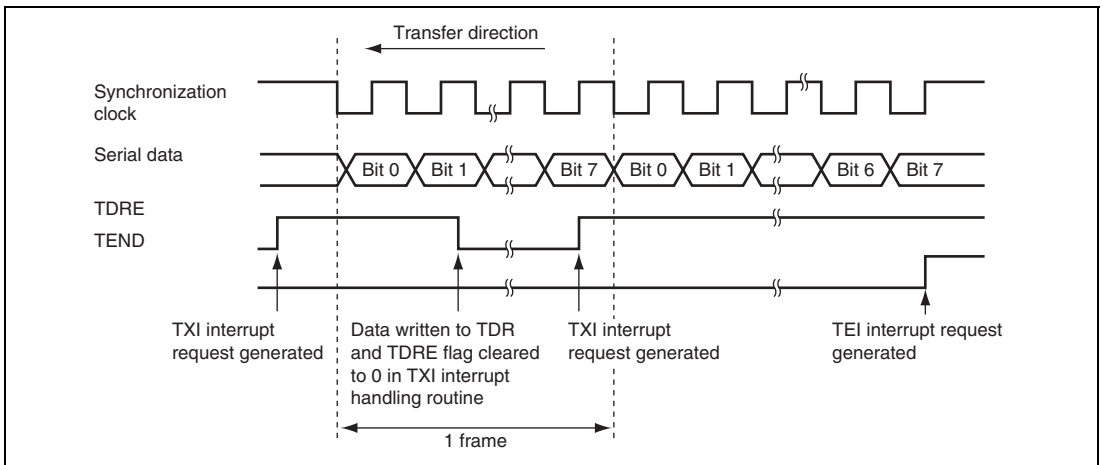
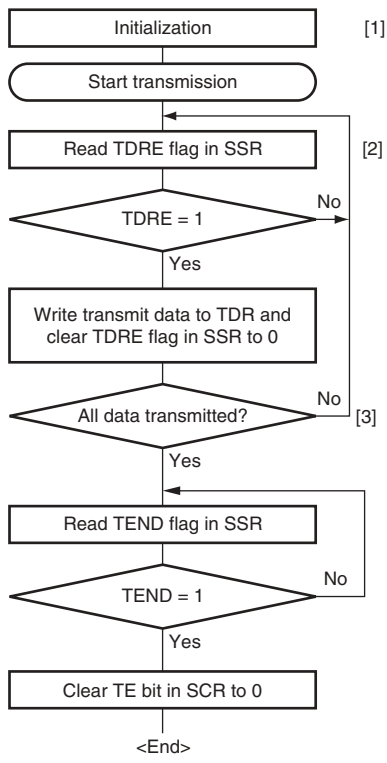

Figure 12.16 Example of SCI Transmit Operation in Clocked Synchronous Mode



- [1] SCI initialization:
The TxD pin is automatically designated as the transmit data output pin.
- [2] SCI status check and transmit data write:
Read SSR and check that the TDRE flag is set to 1, then write transmit data to TDR and clear the TDRE flag to 0.
- [3] Serial transmission continuation procedure:
To continue serial transmission, be sure to read 1 from the TDRE flag to confirm that writing is possible, then

Figure 12.17 Sample Serial Transmission Flowchart

12.6.4 Serial Data Reception (Clocked Synchronous Mode)

Figure 12.18 shows an example of SCI operation for reception in clocked synchronous mode. In serial reception, the SCI operates as described below.

1. The SCI performs internal initialization in synchronization with a synchronization clock input or output, starts receiving data, and stores the receive data in RSR.
2. If an overrun error (when reception of the next data is completed while the RDRF flag is still set to 1) occurs, the ORER bit in SSR is set to 1. If the RIE bit in SCR is set to 1 at this time, an ERI interrupt request is generated. Receive data is not transferred to RDR. The RDRF flag remains to be set to 1.
3. If reception finishes successfully, the RDRF bit in SSR is set to 1, and receive data is transferred to RDR. If the RIE bit in SCR is set to 1 at this time, an RXI interrupt request is generated. Because the RXI interrupt routine reads the receive data transferred to RDR before reception of the next receive data has finished, continuous reception can be enabled.

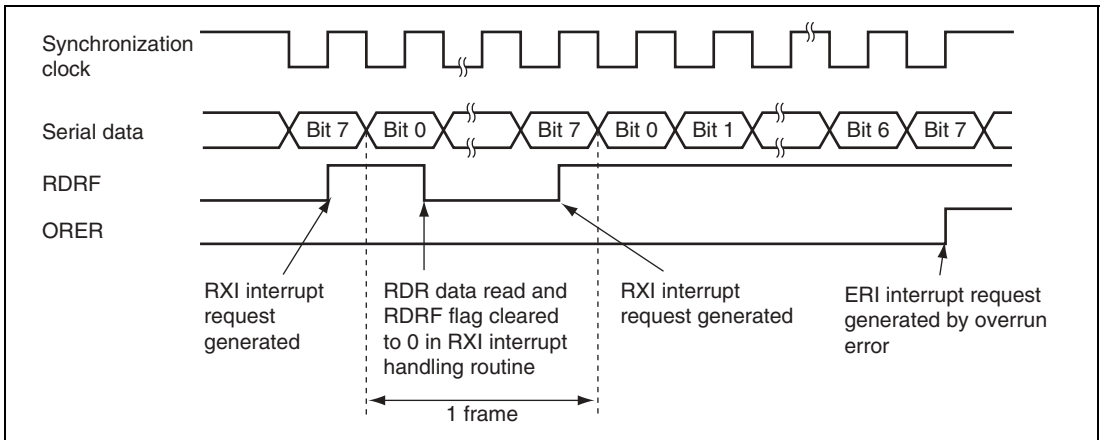

Figure 12.18 Example of SCI Receive Operation in Clocked Synchronous Mode

Reception cannot be resumed while a receive error flag is set to 1. Accordingly, clear the ORER, FER, PER, and RDRF bits to 0 before resuming reception. Figure 12.19 shows a sample flowchart for serial data reception.

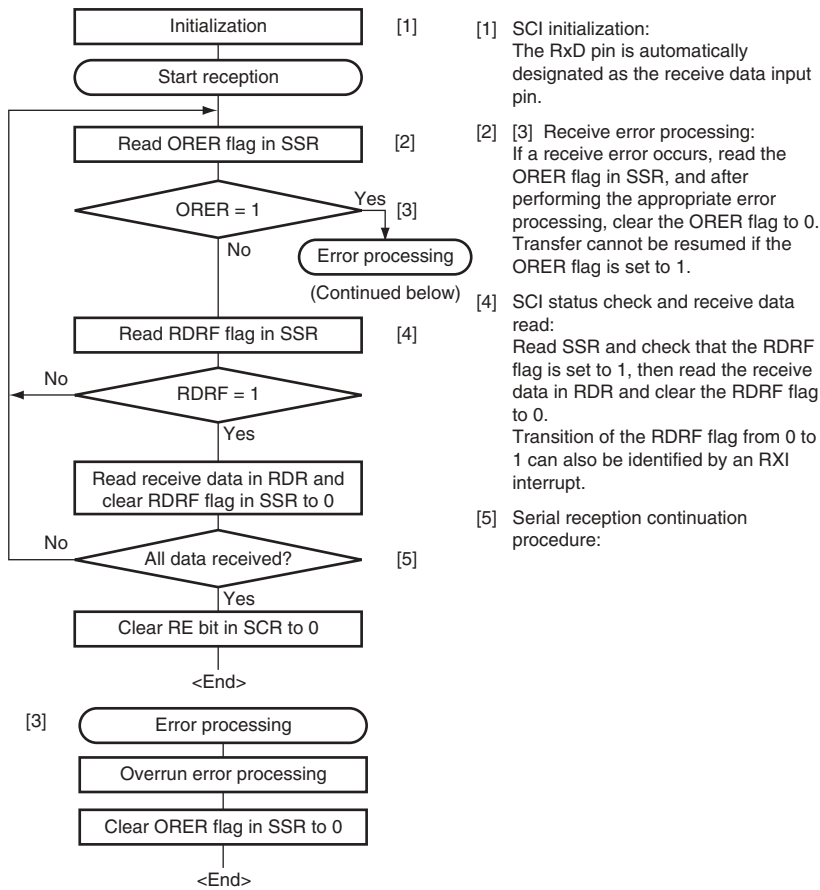
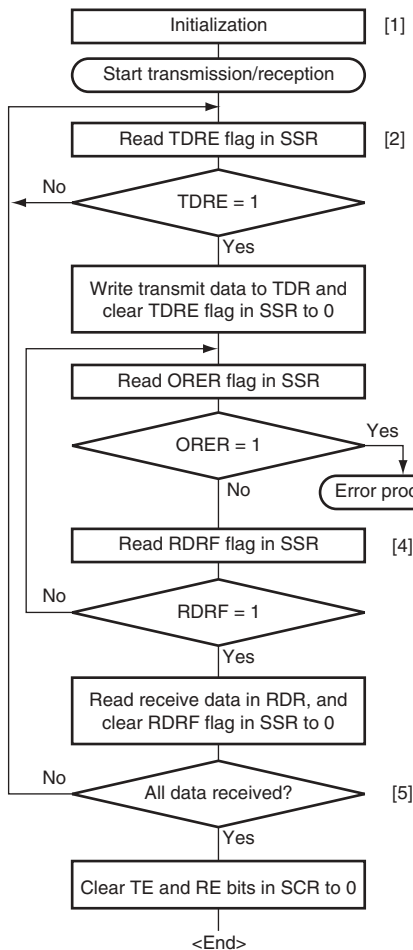

Figure 12.19 Sample Serial Reception Flowchart

12.6.5 Simultaneous Serial Data Transmission and Reception (Clocked Synchronous Mode)

Figure 12.20 shows a sample flowchart for simultaneous serial transmit and receive operations. After initializing the SCI, the following procedure should be used for simultaneous serial data transmit and receive operations. To switch from transmit mode to simultaneous transmit and receive mode, check that the SCI has finished transmission and the TDRE and TEND flags in SSR are set to 1, clear the TE bit in SCR to 0, and then set the TE and RE bits to 1 simultaneously with a single instruction. To switch from receive mode to simultaneous transmit and receive mode, check that the SCI has finished reception, and clear the RE bit to 0. Then after checking that the RDRF bit in SSR and receive error flags (ORER, FER, and PER) are cleared to 0, set the TE and RE bits to 1 simultaneously with a single instruction.



[1] SCI initialization:
The TxD pin is designated as the transmit data output pin, and the RxD pin is designated as the receive data input pin, enabling simultaneous transmit and receive operations.

[2] SCI status check and transmit data write:
Read SSR and check that the TDRE flag is set to 1, then write transmit data to TDR and clear the TDRE flag to 0. Transition of the TDRE flag from 0 to 1 can also be identified by a TXI interrupt.

[3] Receive error processing:
If a receive error occurs, read the ORER flag in SSR, and after performing the appropriate error processing, clear the ORER flag to 0. Transmission/reception cannot be resumed if the ORER flag is set to 1.

[4] SCI status check and receive data read:
Read SSR and check that the RDRF flag is set to 1, then read the receive data in RDR and clear the RDRF flag to 0. Transition of the RDRF flag from 0 to 1 can also be identified by an RXI interrupt.

[5] Serial transmission/reception continuation procedure:
To continue serial transmission/reception, before the MSB (bit 7) of the current frame is received, finish reading the RDRF flag, reading RDR, and clearing the RDRF flag to 0. Also, before the MSB (bit 7) of the current frame is transmitted, read 1 from the

Note: * When switching from transmit or receive operation to simultaneous transmit and receive operations, first clear the TE bit and RE bit to 0, then set both these bits to 1 simultaneously.

Figure 12.20 Sample Flowchart of Simultaneous Serial Transmission and Reception

12.7 Interrupt Sources

Table 12.10 shows the interrupt sources in serial communication interface. A different interrupt vector is assigned to each interrupt source, and individual interrupt sources can be enabled or disabled using the enable bits in SCR.

When the TDRE flag in SSR is set to 1, a TXI interrupt request is generated. When the TEND flag in SSR is set to 1, a TEI interrupt request is generated.

When the RDRF flag in SSR is set to 1, an RXI interrupt request is generated. When the ORER, PER, or FER flag in SSR is set to 1, an ERI interrupt request is generated.

A TEI interrupt is requested when the TEND flag is set to 1 while the TEIE bit is set to 1. If a TEI interrupt and a TXI interrupt are requested simultaneously, the TXI interrupt has priority for acceptance. However, note that if the TDRE and TEND flags are cleared simultaneously by the TXI interrupt routine, the SCI cannot branch to the TEI interrupt routine later.

Table 12.10 SCI Interrupt Sources

Channel	Name	Interrupt Source	Interrupt Flag	Priority
1	ERI1	Receive error	ORER, FER, PER	High ↑ Low
	RXI1	Receive data full	RDRF	
	TXI1	Transmit data empty	TDRE	
	TEI1	Transmit end	TEND	

12.8 Usage Notes

12.8.1 Module Stop Mode Setting

SCI operation can be disabled or enabled using the module stop control register. The initial setting is for SCI operation to be halted. Register access is enabled by clearing module stop mode. For details, refer to section 20, Power-Down Modes.

12.8.2 Break Detection and Processing

When framing error detection is performed, a break can be detected by reading the RxD pin value directly. In a break, the input from the RxD pin becomes all 0s, and so the FER flag in SSR is set, and the PER flag may also be set. Note that, since the SCI continues the receive operation even after receiving a break, even if the FER flag is cleared to 0, it will be set to 1 again.

12.8.3 Mark State and Break Detection

When the TE bit in SCR is 0, the TxD pin is used as an I/O port whose direction (input or output) and level are determined by DR and DDR of the port. This can be used to set the TxD pin to the mark state (high level) or send a break during serial data transmission. To maintain the communication line at mark state until TE is set to 1, set both DDR and DR to 1. Since the TE bit is cleared to 0 at this point, the TxD pin becomes an I/O port, and 1 is output from the TxD pin. To send a break during serial transmission, first set DDR to 1 and DR to 0, and then clear the TE bit to 0. When the TE bit is cleared to 0, the transmitter is initialized regardless of the current transmission state, the TxD pin becomes an I/O port, and 0 is output from the TxD pin.

12.8.4 Receive Error Flags and Transmit Operations (Clocked Synchronous Mode Only)

Transmission cannot be started when a receive error flag (ORER, FER, or RER) in SSR is set to 1, even if the TDRE flag in SSR is cleared to 0. Be sure to clear the receive error flags to 0 before starting transmission. Note also that the receive error flags cannot be cleared to 0 even if the RE bit in SCR is cleared to 0.

12.8.5 Relation between Writing to TDR and TDRE Flag

Data can be written to TDR irrespective of the TDRE flag status in SSR. However, if the new data is written to TDR when the TDRE flag is 0, that is, when the previous data has not been transferred to TSR yet, the previous data in TDR is lost. Be sure to write transmit data to TDR after verifying that the TDRE flag is set to 1.

12.8.6 SCI Operations during Mode Transitions

Transmission: Before making a transition to module stop, software standby, or sub-sleep mode, stop all transmit operations ($TE = TIE = TEIE = 0$). TSR, TDR, and SSR are reset. The states of the output pins during each mode depend on the port settings, and the pins output a high-level signal after mode cancellation. If a transition is made during data transmission, the data being transmitted will be undefined.

To transmit data in the same transmission mode after mode cancellation, set TE to 1, read SSR, write to TDR, clear TDRE in this order, and then start transmission. To transmit data in a different transmission mode, initialize the SCI first.

Figure 12.21 shows a sample flowchart for mode transition during transmission. Figures 12.22 and 12.23 show the pin states during transmission.

Reception: Before making a transition to module stop, software standby, watch, sub-active, or sub-sleep mode, stop reception ($RE = 0$). RSR, RDR, and SSR are reset. If a transition is made during data reception, the data being received will be invalid.

To receive data in the same reception mode after mode cancellation, set RE to 1, and then start reception. To receive data in a different reception mode, initialize the SCI first.

Figure 12.24 shows a sample flowchart for mode transition during reception.

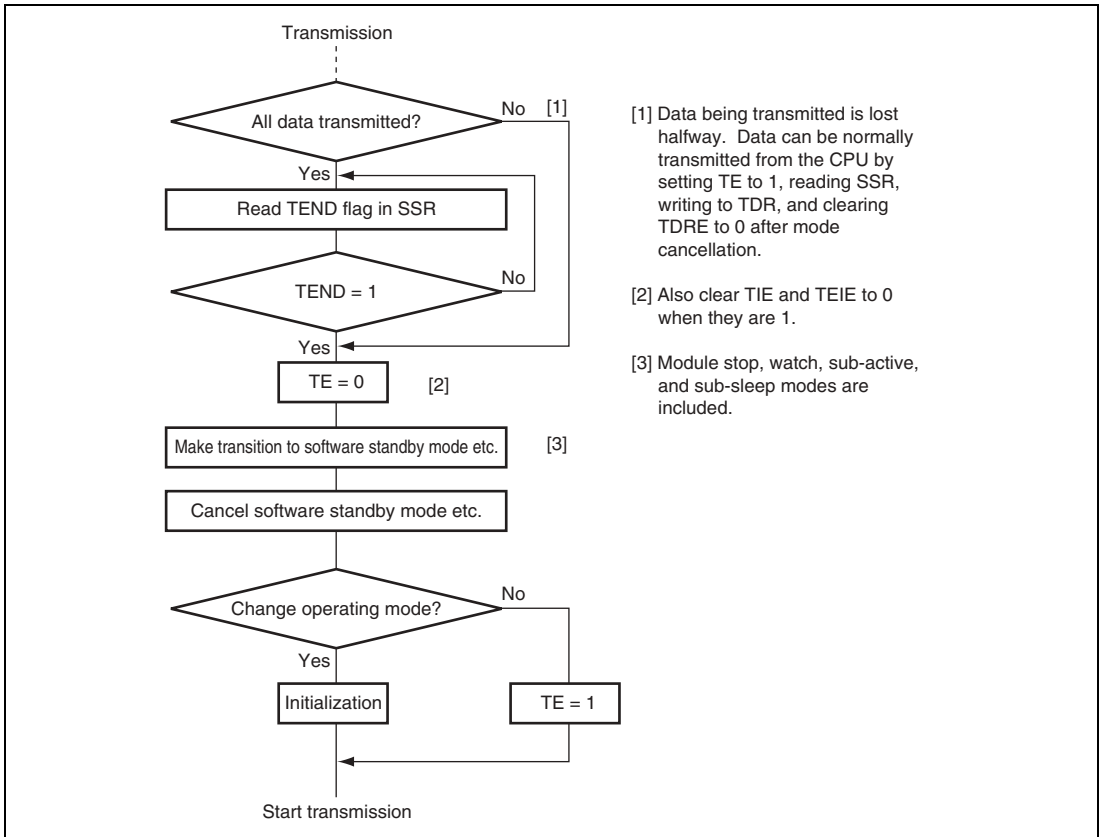

Figure 12.21 Sample Flowchart for Mode Transition during Transmission

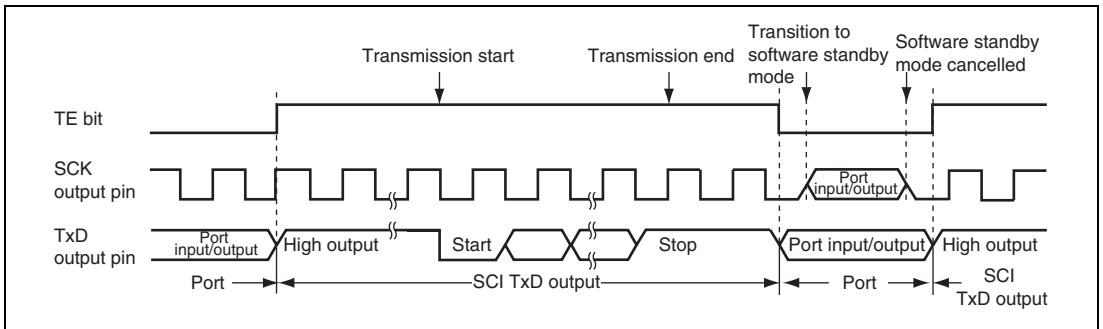

Figure 12.22 Pin States during Transmission in Asynchronous Mode (Internal Clock)

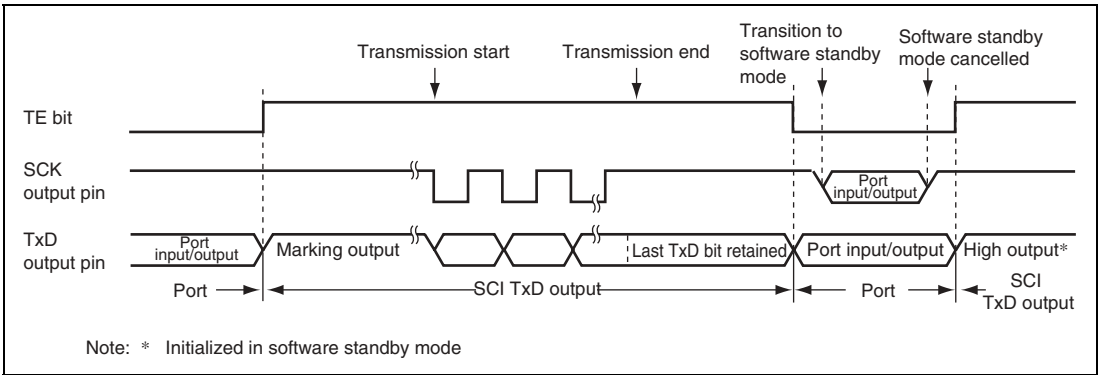

Figure 12.23 Pin States during Transmission in Clocked Synchronous Mode (Internal Clock)

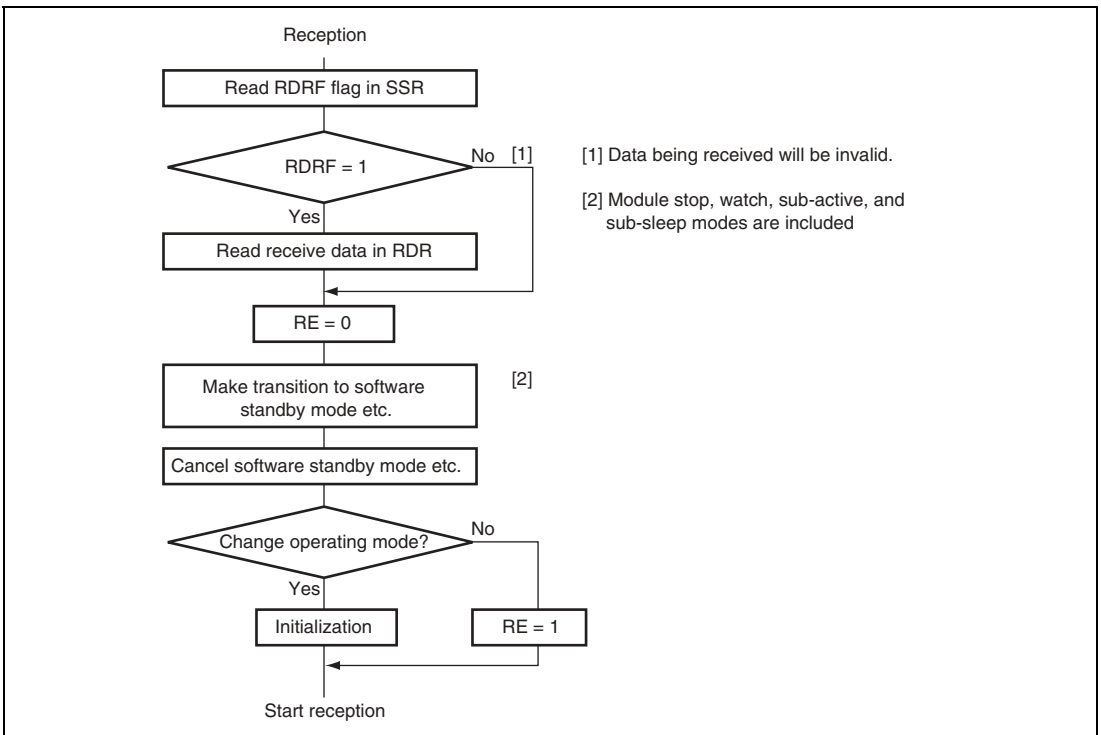

Figure 12.24 Sample Flowchart for Mode Transition during Reception

12.8.7 Switching from SCK Pins to Port Pins

When SCK pins are switched to port pins after transmission has completed, pins are enabled for port output after outputting a low pulse of half a cycle as shown in figure 12.25.

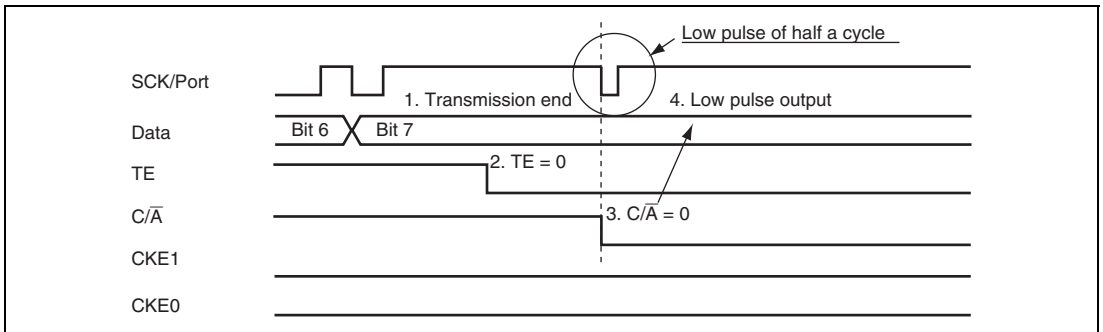

Figure 12.25 Switching from SCK Pins to Port Pins

To prevent the low pulse output that is generated when switching the SCK pins to the port pins, specify the SCK pins for input (pull up the SCK/port pins externally), and follow the procedure below with $DDR = 1$, $DR = 1$, $C/\bar{A} = 1$, $CKE1 = 0$, $CKE1 = 0$, and $TE = 1$.

1. End serial data transmission
2. TE bit = 0
3. CKE1 bit = 1
4. C/A bit = 0 (switch to port output)
5. CKE1 bit = 0

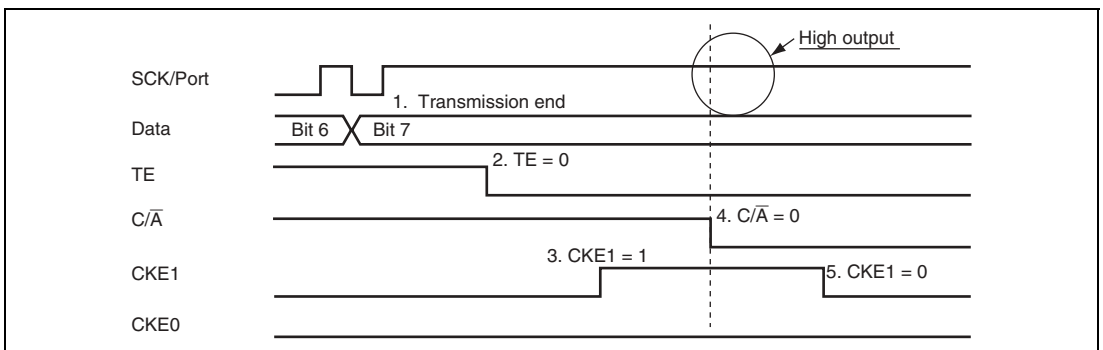

Figure 12.26 Prevention of Low Pulse Output at Switching from SCK Pins to Port Pins

Section 13 I²C Bus Interface (IIC)

This LSI has a two-channel I²C bus interface. The I²C bus interface conforms to and provides a subset of the Philips I²C bus (inter-IC bus) interface functions. The register configuration that controls the I²C bus differs partly from the Philips configuration, however.

13.1 Features

- Selection of addressing format or non-addressing format
 - I²C bus format: addressing format with an acknowledge bit, for master/slave operation
 - Clocked synchronous serial format: non-addressing format without an acknowledge bit, for master operation only
- Conforms to Philips I²C bus interface (I²C bus format)
- Two ways of setting slave address (I²C bus format)
- Start and stop conditions generated automatically in master mode (I²C bus format)
- Selection of the acknowledge output level in reception (I²C bus format)
- Automatic loading of an acknowledge bit in transmission (I²C bus format)
- Wait function in master mode (I²C bus format)
 - A wait can be inserted by driving the SCL pin low after data transfer, excluding acknowledgement.
 - The wait can be cleared by clearing the interrupt flag.
- Wait function (I²C bus format)
 - A wait request can be generated by driving the SCL pin low after data transfer.
 - The wait request is cleared when the next transfer becomes possible.
- Interrupt sources
 - Data transfer end (including when a transition to transmit mode with I²C bus format occurs, when ICDR data is transferred, or during a wait state)
 - Address match: When any slave address matches or the general call address is received in slave receive mode with I²C bus format (including address reception after loss of master arbitration)
 - Start condition detection (in master mode)
 - Stop condition detection (in slave mode)
- Selection of 16 internal clocks (in master mode)
- Direct bus drive (SCL/SDA pin)
 - Eight pins—P52/SCL0, P97/SDA0, P86/SCL1, P42/SDA1, PG4/ExSDAA, PG5/ExSCLA, PG6/ExSDAB, and PG7/ExSCLB—(normally NMOS push-pull outputs) function as NMOS open-drain outputs when the bus drive function is selected.

- Selectable input/output pins*

— Pins, PG4/ExSDAA, PG5/ExSCLA, PG6/ExSDAB, and PG7/ExSCLB, are selectable for the I²C bus input/output pin in each channel.

Note: * The program development tool (emulator) does not support this function.

Figure 13.1 shows a block diagram of the I²C bus interface. Figure 13.2 shows an example of I/O pin connections to external circuits. Since I²C bus interface I/O pins are different in structure from normal port pins, they have different specifications for permissible applied voltages. For details, see section 22, Electrical Characteristics.

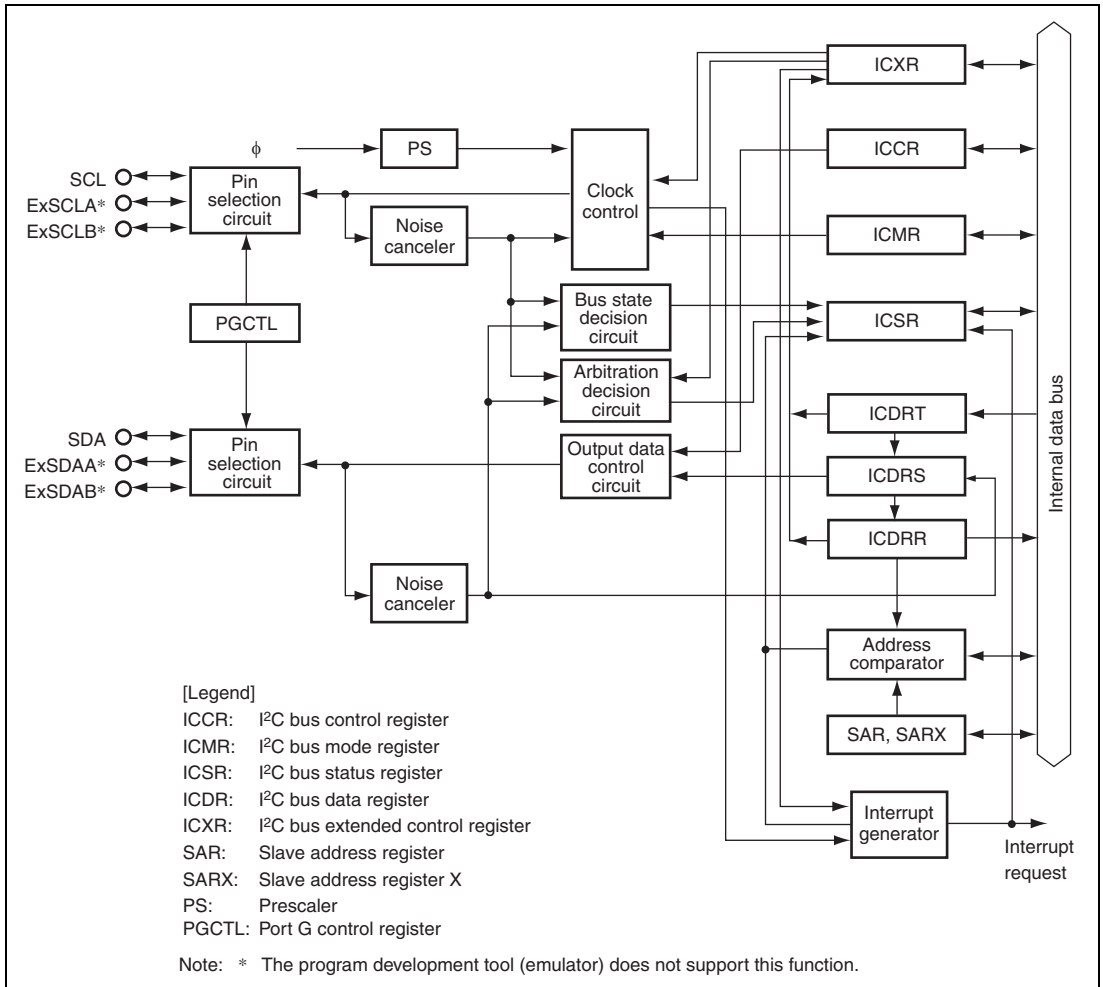

Figure 13.1 Block Diagram of I²C Bus Interface

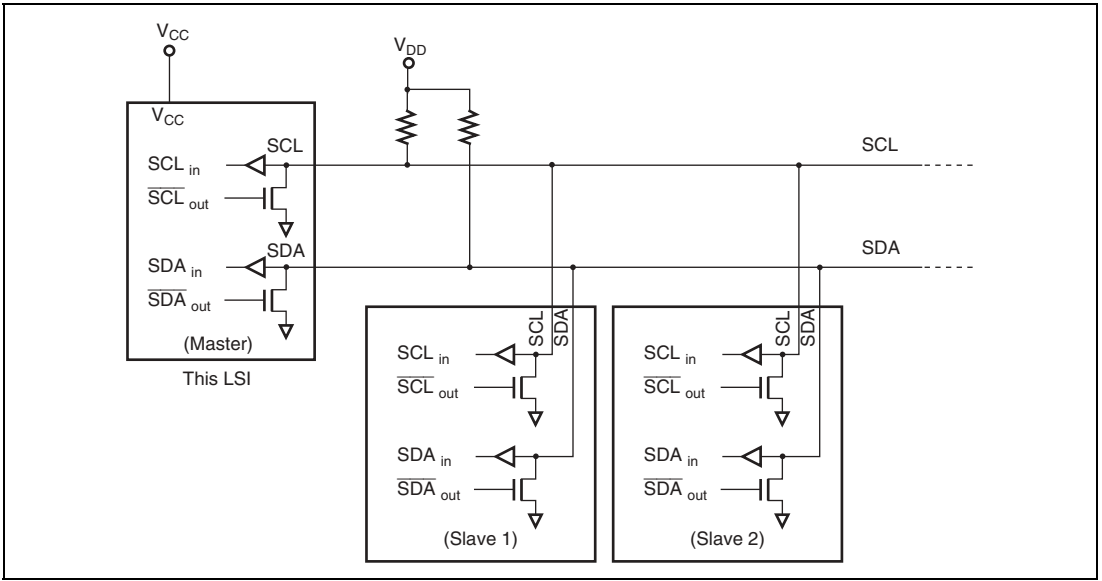

Figure 13.2 I²C Bus Interface Connections (Example: This LSI as Master)

13.2 Input/Output Pins

Table 13.1 summarizes the input/output pins used by the I²C bus interface. The serial clock I/O pin for each channel can be selected from the three pins*. The serial data I/O pin for each channel can be selected from the three pins*. Do not set multiple pins as the serial clock I/O pin or serial data I/O pin for a single channel.

Note: * The program development tool (emulator) does not support this function.

Table 13.1 Pin Configuration

Channel	Symbol* ¹	Input/Output	Function
0	SCL0	Input/Output	Serial clock input/output pin of IIC_0
	SDA0	Input/Output	Serial data input/output pin of IIC_0
1	SCL1	Input/Output	Serial clock input/output pin of IIC_1
	SDA1	Input/Output	Serial data input/output pin of IIC_1
—	ExSCLA* ²	Input/Output	Serial clock input/output pin of IIC_0 or IIC_1
	ExSDAA* ²	Input/Output	Serial data input/output pin of IIC_0 or IIC_1
	ExSCLB* ²	Input/Output	Serial clock input/output pin of IIC_0 or IIC_1
	ExSDAB* ²	Input/Output	Serial data input/output pin of IIC_0 or IIC_1

Notes: 1. In the text, the channel subscript is omitted, and only SCL and SDA are used.
2. The program development tool (emulator) does not support this function.

13.3 Register Descriptions

The I²C bus interface has the following registers. Registers ICDR and SARX and registers ICMR and SAR are allocated to the same addresses. Accessible registers differ depending on the ICE bit in ICCR. When the ICE bit is cleared to 0, SAR and SARX can be accessed, and when the ICE bit is set to 1, ICMR and ICDR can be accessed. For details on the serial timer control register, see section 3.2.3, Serial Timer Control Register (STCR).

- I²C bus data register (ICDR)
- Slave address register (SAR)
- Second slave address register (SARX)
- I²C bus mode register (ICMR)
- I²C bus control register (ICCR)
- I²C bus status register (ICSR)
- DDC switch register (DDCSWR)*¹
- I²C bus extended control register (ICXR)
- Port G control register (PGCTL)*²

Notes: 1. DDCSWR is available only for IIC_0.

2. PGCTL register is common to IIC_0 and IIC_1.

13.3.1 I²C Bus Data Register (ICDR)

ICDR is an 8-bit readable/writable register that is used as a transmit data register when transmitting and a receive data register when receiving. ICDR is internally divided into a shift register (ICDRS), receive buffer (ICDRR), and transmit buffer (ICDRT). Data transfers among these three registers are performed automatically in accordance with changes in the bus state, and they affect the status of internal flags such as ICDRE and ICDRF.

In master transmit mode with the I²C bus format, writing transmit data to ICDR should be performed after start condition detection. When the start condition is detected, previous write data is ignored. In slave transmit mode, writing should be performed after the slave addresses match and the TRS bit is automatically changed to 1.

If the IIC is in transmit mode (TRS = 1) and ICDRT has the next transmit data (the ICDRE flag is 0) after successful transmission/reception of one frame of data using ICDRS, data is transferred automatically from ICDRT to ICDRS.

If the IIC is in transmit mode (TRS = 1) and ICDRT has the next data (the ICDRE flag is 0), data is transferred automatically from ICDRT to ICDRS, following transmission of one frame of data using ICDRS. When the ICDRE flag is 1 and the next transmit data writing is waited, data is transferred automatically from ICDRT to ICDRS by writing to ICDR. If I²C is in receive mode (TRS = 0), no data is transferred from ICDRT to ICDRS. Note that data should not be written to ICDR in receive mode.

Reading receive data from ICDR is performed after data is transferred from ICDRS to ICDRR.

If I²C is in receive mode and no previous data remains in ICDRR (the ICDRF flag is 0), data is transferred automatically from ICDRS to ICDRR, following reception of one frame of data using ICDRS. If additional data is received while the ICDRF flag is 1, data is transferred automatically from ICDRS to ICDRR by reading from ICDR. In transmit mode, no data is transferred from ICDRS to ICDRR. Always set I²C to receive mode before reading from ICDR.

If the number of bits in a frame, excluding the acknowledge bit, is less than eight, transmit data and receive data are stored differently. Transmit data should be written justified toward the MSB side when MLS = 0 in ICMR, and toward the LSB side when MLS = 1. Receive data bits should be read from the LSB side when MLS = 0, and from the MSB side when MLS = 1.

ICDR can be written to and read from only when the ICE bit is set to 1 in ICCR. The initial value of ICDR is undefined.

13.3.2 Slave Address Register (SAR)

SAR sets the slave address and selects the communication format. If the LSI is in slave mode with the I²C bus format selected, when the FS bit is set to 0 and the upper 7 bits of SAR match the upper 7 bits of the first frame received after a start condition, the LSI operates as the slave device specified by the master device. SAR can be accessed only when the ICE bit in ICCR is cleared to 0.

Bit	Bit Name	Initial Value	R/W	Description
7	SVA6	0	R/W	Slave Address 6 to 0
6	SVA5	0	R/W	Set a slave address.
5	SVA4	0	R/W	
4	SVA3	0	R/W	
3	SVA2	0	R/W	
2	SVA1	0	R/W	
1	SVA0	0	R/W	
0	FS	0	R/W	Format Select Selects the communication format together with the FSX bit in SARX. See table 13.2. This bit should be set to 0 when general call address recognition is performed.

13.3.3 Second Slave Address Register (SARX)

SARX sets the second slave address and selects the communication format. If the LSI is in slave mode with the I²C bus format selected, when the FSX bit is set to 0 and the upper 7 bits of SARX match the upper 7 bits of the first frame received after a start condition, the LSI operates as the slave device specified by the master device. SARX can be accessed only when the ICE bit in ICCR is cleared to 0.

Bit	Bit Name	Initial Value	R/W	Description
7	SVAX6	0	R/W	Second Slave Address 6 to 0
6	SVAX5	0	R/W	Set the second slave address.
5	SVAX4	0	R/W	
4	SVAX3	0	R/W	
3	SVAX2	0	R/W	
2	SVAX1	0	R/W	
1	SVAX0	0	R/W	
0	FSX	1	R/W	Format Select X Selects the communication format together with the FS bit in SAR. See table 13.2.

Table 13.2 Communication Format

SAR	SARX	Operating Mode
0	0	I ² C bus format <ul style="list-style-type: none"> • SAR and SARX slave addresses recognized • General call address recognized
	1	I ² C bus format <ul style="list-style-type: none"> • SAR slave address recognized • SARX slave address ignored • General call address recognized
1	0	I ² C bus format <ul style="list-style-type: none"> • SAR slave address ignored • SARX slave address recognized • General call address ignored
	1	Clocked synchronous serial format <ul style="list-style-type: none"> • SAR and SARX slave addresses ignored • General call address ignored

- I²C bus format: addressing format with an acknowledge bit
- Clocked synchronous serial format: non-addressing format without an acknowledge bit, for master mode only

13.3.4 I²C Bus Mode Register (ICMR)

ICMR sets the communication format and transfer rate. It can only be accessed when the ICE bit in ICCR is set to 1.

Bit	Bit Name	Initial Value	R/W	Description
7	MLS	0	R/W	MSB-First/LSB-First Select 0: MSB-first 1: LSB-first Set this bit to 0 when the I ² C bus format is used.
6	WAIT	0	R/W	Wait Insertion Bit This bit is valid only in master mode with the I ² C bus format. 0: Data and the acknowledge bit are transferred consecutively with no wait inserted. 1: After the fall of the clock for the final data bit (8 th clock), the IRIC flag is set to 1 in ICCR, and a wait state begins (with SCL at the low level). When the IRIC flag is cleared to 0 in ICCR, the wait ends and the acknowledge bit is transferred. For details, see section 13.4.7, IRIC Setting Timing and SCL Control.
5	CKS2	0	R/W	Transfer Clock Select 2 to 0
4	CKS1	0	R/W	These bits are used only in master mode.
3	CKS0	0	R/W	These bits select the required transfer rate, together with the IICX1 (IIC_1) and IICX0 (IIC_0) bits in STCR. See table 13.3.

Bit	Bit Name	Initial Value	R/W	Description																											
2	BC2	0	R/W	Bit Counter 2 to 0																											
1	BC1	0	R/W	These bits specify the number of bits to be transferred next. Bit BC2 to BC0 settings should be made during an interval between transfer frames. If bits BC2 to BC0 are set to a value other than 000, the setting should be made while the SCL line is low.																											
0	BC0	0	R/W																												
<p>The bit counter is initialized to 000 when a start condition is detected. The value returns to 000 at the end of a data transfer.</p>																															
<table border="0"> <thead> <tr> <th colspan="2">I²C Bus Format</th> <th>Clocked Synchronous Serial Mode</th> </tr> </thead> <tbody> <tr> <td>000: 9 bits</td> <td></td> <td>000: 8 bits</td> </tr> <tr> <td>001: 2 bits</td> <td></td> <td>001: 1 bits</td> </tr> <tr> <td>010: 3 bits</td> <td></td> <td>010: 2 bits</td> </tr> <tr> <td>011: 4 bits</td> <td></td> <td>011: 3 bits</td> </tr> <tr> <td>100: 5 bits</td> <td></td> <td>100: 4 bits</td> </tr> <tr> <td>101: 6 bits</td> <td></td> <td>101: 5 bits</td> </tr> <tr> <td>110: 7 bits</td> <td></td> <td>110: 6 bits</td> </tr> <tr> <td>111: 8 bits</td> <td></td> <td>111: 7 bits</td> </tr> </tbody> </table>					I ² C Bus Format		Clocked Synchronous Serial Mode	000: 9 bits		000: 8 bits	001: 2 bits		001: 1 bits	010: 3 bits		010: 2 bits	011: 4 bits		011: 3 bits	100: 5 bits		100: 4 bits	101: 6 bits		101: 5 bits	110: 7 bits		110: 6 bits	111: 8 bits		111: 7 bits
I ² C Bus Format		Clocked Synchronous Serial Mode																													
000: 9 bits		000: 8 bits																													
001: 2 bits		001: 1 bits																													
010: 3 bits		010: 2 bits																													
011: 4 bits		011: 3 bits																													
100: 5 bits		100: 4 bits																													
101: 6 bits		101: 5 bits																													
110: 7 bits		110: 6 bits																													
111: 8 bits		111: 7 bits																													

Table 13.3 I²C Transfer Rate

STCR		ICMR		Clock	Transfer Rate		
Bits 5 and 6	Bit 5	Bit 4	Bit 3		$\phi = 5 \text{ MHz}$	$\phi = 8 \text{ MHz}$	$\phi = 10 \text{ MHz}$
IICX	CKS2	CKS1	CKS0				
0	0	0	0	$\phi/28$	179 kHz	286 kHz	357 kHz
0	0	0	1	$\phi/40$	125 kHz	200 kHz	250 kHz
0	0	1	0	$\phi/48$	104 kHz	167 kHz	208 kHz
0	0	1	1	$\phi/64$	78.1 kHz	125 kHz	156 kHz
0	1	0	0	$\phi/80$	62.5 kHz	100 kHz	125 kHz
0	1	0	1	$\phi/100$	50.0 kHz	80.0 kHz	100 kHz
0	1	1	0	$\phi/112$	44.6 kHz	71.4 kHz	89.3 kHz
0	1	1	1	$\phi/128$	39.1 kHz	62.5 kHz	78.1 kHz
1	0	0	0	$\phi/56$	89.3 kHz	143 kHz	179 kHz
1	0	0	1	$\phi/80$	62.5 kHz	100 kHz	125 kHz
1	0	1	0	$\phi/96$	52.1 kHz	83.3 kHz	104 kHz
1	0	1	1	$\phi/128$	39.1 kHz	62.5 kHz	78.1 kHz
1	1	0	0	$\phi/160$	31.3 kHz	50.0 kHz	62.5 kHz
1	1	0	1	$\phi/200$	25.0 kHz	40.0 kHz	50.0 kHz
1	1	1	0	$\phi/224$	22.3 kHz	35.7 kHz	44.6 kHz
1	1	1	1	$\phi/256$	19.5 kHz	31.3 kHz	39.1 kHz

13.3.5 I²C Bus Control Register (ICCR)

ICCR controls the I²C bus interface and performs interrupt flag confirmation.

Bit	Bit Name	Initial Value	R/W	Description															
7	ICE	0	R/W	<p>I²C Bus Interface Enable</p> <p>0: I²C bus interface modules are stopped and I²C bus interface module internal state is initialized. SAR and SARX can be accessed.</p> <p>1: I²C bus interface modules can perform transfer operation, and the ports function as the SCL and SDA input/output pins. ICMR and ICDR can be accessed.</p>															
6	IEIC	0	R/W	<p>I²C Bus Interface Interrupt Enable</p> <p>0: Disables interrupts from the I²C bus interface to the CPU</p> <p>1: Enables interrupts from the I²C bus interface to the CPU.</p>															
5	MST	0	R/W	Master/Slave Select															
4	TRS	0	R/W	<p>Transmit/Receive Select</p> <table border="0"> <tr> <td>MST</td> <td>TRS</td> <td></td> </tr> <tr> <td>0</td> <td>0</td> <td>: Slave receive mode</td> </tr> <tr> <td>0</td> <td>1</td> <td>: Slave transmit mode</td> </tr> <tr> <td>1</td> <td>0</td> <td>: Master receive mode</td> </tr> <tr> <td>1</td> <td>1</td> <td>: Master transmit mode</td> </tr> </table> <p>Both these bits will be cleared by hardware when they lose in a bus contention in master mode with the I²C bus format. In slave receive mode with I²C bus format, the R/W bit in the first frame immediately after the start condition sets these bits in receive mode or transmit mode automatically by hardware.</p> <p>Modification of the TRS bit during transfer is deferred until transfer is completed, and the changeover is made after completion of the transfer.</p>	MST	TRS		0	0	: Slave receive mode	0	1	: Slave transmit mode	1	0	: Master receive mode	1	1	: Master transmit mode
MST	TRS																		
0	0	: Slave receive mode																	
0	1	: Slave transmit mode																	
1	0	: Master receive mode																	
1	1	: Master transmit mode																	

Bit	Bit Name	Initial Value	R/W	Description
5	MST	0	R/W	[MST clearing conditions]
4	TRS	0		<ol style="list-style-type: none"> When 0 is written by software When lost in bus contention in I²C bus format master mode [MST setting conditions] <ol style="list-style-type: none"> When 1 is written by software (for MST clearing condition 1) When 1 is written in MST after reading MST = 0 (for MST clearing condition 2) [TRS clearing conditions] <ol style="list-style-type: none"> When 0 is written by software (except for TRS setting condition 3) When 0 is written in TRS after reading TRS = 1 (for TRS setting condition 3) When lost in bus contention in I²C bus format master mode [TRS setting conditions] <ol style="list-style-type: none"> When 1 is written by software (except for TRS clearing condition 3) When 1 is written in TRS after reading TRS = 0 (for TRS clearing condition 3) When 1 is received as the $\overline{R/W}$ bit after the first frame address matching in I²C bus format slave mode
3	ACKE	0	R/W	<p>Acknowledge Bit Decision and Selection</p> <p>0: The value of the acknowledge bit is ignored, and continuous transfer is performed. The value of the received acknowledge bit is not indicated by the ACKB bit in ICSR, which is always 0.</p> <p>1: If the received acknowledge bit is 1, continuous transfer is halted.</p> <p>Depending on the receiving device, the acknowledge bit may be significant, in indicating completion of processing of the received data, for instance, or may be fixed at 1 and have no significance.</p>

Bit	Bit Name	Initial Value	R/W	Description
2	BBSY	0	R/W*	Bus Busy
0	SCP	1	W	Start Condition/Stop Condition Prohibit

In master mode:

- Writing 0 in BBSY and 0 in SCP: A stop condition is issued
- Writing 1 in BBSY and 0 in SCP: A start condition and a restart condition are issued

In slave mode:

- Writing to the BBSY flag is disabled.

[BBSY setting condition]

When the SDA level changes from high to low under the condition of SCL = high, assuming that the start condition has been issued.

[BBSY clearing condition]

When the SDA level changes from low to high under the condition of SCL = high, assuming that the stop condition has been issued.

To issue a start/stop condition, use the MOV instruction.

The I²C bus interface must be set in master transmit mode before the issue of a start condition. Set MST to 1 and TRS to 1 before writing 1 in BBSY and 0 in SCP.

The BBSY flag can be read to check whether the I²C bus (SCL, SDA) is busy or free.

The SCP bit is always read as 1. If 0 is written, the data is not stored.

Note: * The value in BBSY flag does not change even if written.

Bit	Bit Name	Initial Value	R/W	Description
1	IRIC	0	R/(W)*	<p>I²C Bus Interface Interrupt Request Flag</p> <p>Indicates that the I²C bus interface has issued an interrupt request to the CPU.</p> <p>IRIC is set at different times depending on the FS bit in SAR, the FSX bit in SARX, and the WAIT bit in ICMR. See section 13.4.7, IRIC Setting Timing and SCL Control. The conditions under which IRIC is set also differ depending on the setting of the ACKE bit in ICCR.</p> <p>[Setting conditions]</p> <p>I²C bus format master mode:</p> <ul style="list-style-type: none"> • When a start condition is detected in the bus line state after a start condition is issued (when the ICDRE flag is set to 1 because of first frame transmission) • When a wait is inserted between the data and acknowledge bit when the WAIT bit is 1 (fall of the 8th transmit/receive clock) • At the end of data transfer (rise of the 9th transmit/receive clock while no wait is inserted) • When a slave address is received after bus arbitration is lost (the first frame after the start condition) • If 1 is received as the acknowledge bit (when the ACKB bit in ICSR is set to 1) when the ACKE bit is 1 • When the AL flag is set to 1 after bus arbitration is lost while the ALIE bit is 1 <p>I²C bus format slave mode:</p> <ul style="list-style-type: none"> • When the slave address (SVA or SVAX) matches (when the AAS or AASX flag in ICSR is set to 1) and at the end of data transfer up to the subsequent retransmission start condition or stop condition detection (rise of the 9th transmit/receive clock) • When the general call address is detected (when 0 is received as the R/W bit and the ADZ flag in ICSR is set to 1) and at the end of data reception up to the subsequent retransmission start condition or stop condition detection (rise of the 9th receive clock) • If 1 is received as the acknowledge bit (when the ACKB bit in ICSR is set to 1) while the ACKE bit is 1 • When a stop condition is detected (when the STOP or ESTP flag in ICSR is set to 1) while the STOPIM bit is 0

Bit	Bit Name	Initial Value	R/W	Description
1	IRIC	0	R/(W)*	<p>Clocked synchronous serial format mode:</p> <ul style="list-style-type: none"> At the end of data transfer (rise of the 8th transmit/receive) When a start condition is detected <p>When the ICDRE or ICDRF flag is set to 1 in any operating mode:</p> <ul style="list-style-type: none"> When a start condition is detected in transmit mode (when a start condition is detected in transmit mode and the ICDRE flag is set to 1) When data is transferred among ICDR and buffer (when data is transferred from ICDRT to ICDRS in transmit mode and the ICDRE flag is set to 1, or when data is transferred from ICDRS to ICDRR in receive mode and the ICDRF flag is set to 1) <p>[Clearing conditions]</p> <ul style="list-style-type: none"> When 0 is written in IRIC after reading IRIC = 1

Note: * Only 0 can be written, to clear the flag.

When, with the I²C bus format selected, IRIC is set to 1 and an interrupt is generated, other flags must be checked in order to identify the source that set IRIC to 1. Although each source has a corresponding flag, caution is needed at the end of a transfer.

When the ICDRE or ICDRF flag is set, the IRTR flag may or may not be set. The IRTR flag is not set at the end of a data transfer up to detection of a retransmission start condition or stop condition after a slave address (SVA) or general call address match in I²C bus format slave mode.

Tables 13.4 and 13.5 show the relationship between the flags and the transfer states.

Table 13.4 Flags and Transfer States (Master Mode)

MST	TRS	BBSY	ESTP	STOP	IRTR	AASX	AL	AAS	ADZ	ACKB	ICDRF	ICDRE	State
1	1	0	0	0	0	0↓	0	0↓	0↓	0	—	0	Idle state (flag clearing required)
1	1	1↑	0	0	1↑	0	0	0	0	0	—	1↑	Start condition detected
1	—	1	0	0	—	0	0	0	0	—	—	—	Wait state
1	1	1	0	0	—	0	0	0	0	1↑	—	—	Transmission end (ACKE=1 and ACKB=1)
1	1	1	0	0	1↑	0	0	0	0	0	—	1↑	Transmission end with ICDRE=0
1	1	1	0	0	—	0	0	0	0	0	—	0↓	ICDR write with the above state
1	1	1	0	0	—	0	0	0	0	0	—	1	Transmission end with ICDRE=1
1	1	1	0	0	—	0	0	0	0	0	—	0↓	ICDR write with the above state or after start condition detected
1	1	1	0	0	1↑	0	0	0	0	0	—	1↑	Automatic data transfer from ICDRT to ICDRS with the above state
1	0	1	0	0	1↑	0	0	0	0	—	1↑	—	Reception end with ICDRF=0
1	0	1	0	0	—	0	0	0	0	—	0↓	—	ICDR read with the above state
1	0	1	0	0	—	0	0	0	0	—	1	—	Reception end with ICDRF=1
1	0	1	0	0	—	0	0	0	0	—	0↓	—	ICDR read with the above state
1	0	1	0	0	1↑	0	0	0	0	—	1↑	—	Automatic data transfer from ICDRS to ICDRR with the above state
0↓	0↓	1	0	0	—	0	1↑	0	0	—	—	—	Arbitration lost
1	—	0↓	0	0	—	0	0	0	0	—	—	0↓	Stop condition detected

[Legend]

- 0: 0-state retained
- 1: 1-state retained
- : Previous state retained
- 0↓: Cleared to 0
- 1↑: Set to 1

Table 13.5 Flags and Transfer States (Slave Mode)

MST	TRS	BBSY	ESTP	STOP	IRTR	AASX	AL	AAS	ADZ	ACKB	ICDRF	ICDRE	State
0	0	0	0	0	0	0	0	0	0	0	—	0	Idle state (flag clearing required)
0	0	1↑	0	0	0	0↓	0	0	0	0	—	1↑	Start condition detected
0	1↑/0 *1	1	0	0	0	0	—	1↑	0	0	1↑	1	SAR match in first frame (SARX≠SAR)
0	0	1	0	0	0	0	—	1↑	1↑	0	1↑	1	General call address match in first frame (SARX≠H'00)
0	1↑/0 *1	1	0	0	1↑	1↑	—	0	0	0	1↑	1	SARS match in first frame (SAR≠SARX)
0	1	1	0	0	—	—	—	—	0	1↑	—	—	Transmission end (ACKE=1 and ACKB=1)
0	1	1	0	0	1↑/0 *1	—	—	—	0	0	—	1↑	Transmission end with ICDRE=0
0	1	1	0	0	—	—	0↓	0↓	0	0	—	0↓	ICDR write with the above state
0	1	1	0	0	—	—	—	—	1	0	—	1	Transmission end with ICDRE=1
0	1	1	0	0	—	—	0↓	0↓	0	0	—	0↓	ICDR write with the above state
0	1	1	0	0	1↑/0 *2	—	0	0	0	0	—	1↑	Automatic data transfer from ICDRT to ICDRS with the above state
0	0	1	0	0	1↑/0 *2	—	—	—	—	—	1↑	—	Reception end with ICDRF=0
0	0	1	0	0	—	—	0↓	0↓	0↓	—	0↓	—	ICDR read with the above state

Table 13.5 Flags and Transfer States (Slave Mode) (cont)

MST	TRS	BBSY	ESTP	STOP	IRTR	AASX	AL	AAS	ADZ	ACKB	ICDRF	ICDRE	State
0	0	1	0	0	—	—	—	—	—	—	1	—	Reception end with ICDRF=1
0	0	1	0	0	—	—	0↓	0↓	0↓	—	0↓	—	ICDR read with the above state
0	0	1	0	0	1↑/0 *2	—	0	0	0	—	1↑	—	Automatic data transfer from ICDRS to ICDRR with the above state
0	—	0↓	1↑/0 *3	0/1↑ *3	—	—	—	—	—	—	—	0↓	Stop condition detected

[Legend]

- 0: 0-state retained
- 1: 1-state retained
- : Previous state retained
- 0↓: Cleared to 0
- 1↑: Set to 1

- Notes:
1. Set to 1 when 1 is received as a R/\overline{W} bit following an address.
 2. Set to 1 when the AASX bit is set to 1.
 3. When ESTP = 1, STOP is 0, or when STOP = 1, ESTP is 0.

13.3.6 I²C Bus Status Register (ICSR)

ICSR consists of status flags. Also see tables 13.4 and 13.5.

Bit	Bit Name	Initial Value	R/W	Description
7	ESTP	0	R/(W)*	<p>Error Stop Condition Detection Flag</p> <p>This bit is valid in I²C bus format slave mode.</p> <p>[Setting condition]</p> <p>When a stop condition is detected during frame transfer.</p> <p>[Clearing conditions]</p> <ul style="list-style-type: none">• When 0 is written in ESTP after reading ESTP = 1• When the IRIC flag in ICCR is cleared to 0
6	STOP	0	R/(W)*	<p>Normal Stop Condition Detection Flag</p> <p>This bit is valid in I²C bus format slave mode.</p> <p>[Setting condition]</p> <p>When a stop condition is detected after frame transfer completion.</p> <p>[Clearing conditions]</p> <ul style="list-style-type: none">• When 0 is written in STOP after reading STOP = 1• When the IRIC flag is cleared to 0
5	IRTR	0	R/(W)*	<p>I²C Bus Interface Continuous Transfer Interrupt Request Flag</p> <p>Indicates that the I²C bus interface has issued an interrupt request to the CPU, and the source is completion of reception/transmission of one frame in continuous transmission/reception. When the IRTR flag is set to 1, the IRIC flag is also set to 1 at the same time.</p> <p>[Setting conditions]</p> <p>I²C bus format slave mode:</p> <ul style="list-style-type: none">• When the ICDRE or ICDRF flag in ICDR is set to 1 when AASX = 1 <p>Master mode or clocked synchronous serial format mode with I²C bus format:</p> <ul style="list-style-type: none">• When the ICDRE or ICDRF flag is set to 1 <p>[Clearing conditions]</p> <ul style="list-style-type: none">• When 0 is written after reading IRTR = 1• When the IRIC flag is cleared to 0 while ICE is 1

Bit	Bit Name	Initial Value	R/W	Description
4	AASX	0	R/(W)*	<p>Second Slave Address Recognition Flag</p> <p>In I²C bus format slave receive mode, this flag is set to 1 if the first frame following a start condition matches bits SVAX6 to SVAX0 in SARX.</p> <p>[Setting condition]</p> <p>When the second slave address is detected in slave receive mode and FSX = 0 in SARX</p> <p>[Clearing conditions]</p> <ul style="list-style-type: none"> • When 0 is written in AASX after reading AASX = 1 • When a start condition is detected • In master mode
3	AL	0	R/(W)*	<p>Arbitration Lost Flag</p> <p>Indicates that arbitration was lost in master mode.</p> <p>[Setting conditions]</p> <p>When ALSL = 0</p> <ul style="list-style-type: none"> • If the internal SDA and SDA pin disagree at the rise of SCL in master transmit mode • If the internal SCL line is high at the fall of SCL in master transmit mode <p>When ALSL = 1</p> <ul style="list-style-type: none"> • If the internal SDA and SDA pin disagree at the rise of SCL in master transmit mode • If the SDA pin is driven low by another device before the I²C bus interface drives the SDA pin low, after the start condition instruction was executed in master transmit mode <p>[Clearing conditions]</p> <ul style="list-style-type: none"> • When ICDR is written to (transmit mode) or read from (receive mode) • When 0 is written in AL after reading AL = 1

Bit	Bit Name	Initial Value	R/W	Description
2	AAS	0	R/(W)*	<p>Slave Address Recognition Flag</p> <p>In I²C bus format slave receive mode, this flag is set to 1 if the first frame following a start condition matches bits SVA6 to SVA0 in SAR, or if the general call address (H'00) is detected.</p> <p>[Setting condition]</p> <p>When the slave address or general call address (one frame including a R/W bit is H'00) is detected in slave receive mode and FS = 0 in SAR</p> <p>[Clearing conditions]</p> <ul style="list-style-type: none"> • When ICDR is written to (transmit mode) or read from (receive mode) • When 0 is written in AAS after reading AAS = 1 • In master mode
1	ADZ	0	R/(W)*	<p>General Call Address Recognition Flag</p> <p>In I²C bus format slave receive mode, this flag is set to 1 if the first frame following a start condition is the general call address (H'00).</p> <p>[Setting condition]</p> <p>When the general call address (one frame including a R/W bit is H'00) is detected in slave receive mode and FS = 0 or FSX = 0</p> <p>[Clearing conditions]</p> <ul style="list-style-type: none"> • When ICDR is written to (transmit mode) or read from (receive mode) • When 0 is written in ADZ after reading ADZ = 1 • In master mode <p>If a general call address is detected while FS = 1 and FSX = 0, the ADZ flag is set to 1; however, the general call address is not recognized (AAS flag is not set to 1).</p>

Bit	Bit Name	Initial Value	R/W	Description
0	ACKB	0	R/W	<p>Acknowledge Bit</p> <p>Stores acknowledge data.</p> <p>Transmit mode:</p> <p>[Setting condition]</p> <p>When 1 is received as the acknowledge bit when ACKE = 1 in transmit mode</p> <p>[Clearing conditions]</p> <ul style="list-style-type: none"> • When 0 is received as the acknowledge bit when ACKE = 1 in transmit mode • When 0 is written to the ACKE bit <p>Receive mode:</p> <p>0: Returns 0 as acknowledge data after data reception</p> <p>1: Returns 1 as acknowledge data after data reception</p> <p>When this bit is read, the value loaded from the bus line (returned by the receiving device) is read in transmission (when TRS = 1). In reception (when TRS = 0), the value set by internal software is read.</p> <p>When this bit is written, acknowledge data that is returned after receiving is rewritten regardless of the TRS value. If bit in ICSR is written using bit-manipulation instructions, the acknowledge data should be re-set since the acknowledge data setting is rewritten by the ACKB bit reading value.</p> <p>Write the ACKE bit to 0 to clear the ACKB flag to 0, before transmission is ended and a stop condition is issued in master mode, or before transmission is ended and SDA is released to issue a stop condition by a master device.</p>

Note: * Only 0 can be written to clear the flag.

13.3.7 DDC Switch Register (DDCSWR)

DDCSWR controls IIC internal latch clearance.

Bit	Bit Name	Initial Value	R/W	Description
7 to 5	—	All 0	R/W	Reserved The initial value should not be changed.
4	—	0	R	Reserved
3	CLR3	1	W*	IIC Clear 3 to 0
2	CLR2	1	W*	Controls initialization of the internal state of IIC_0 and IIC_1.
1	CLR1	1	W*	00--: Setting prohibited
0	CLR0	1	W*	0100: Setting prohibited 0101: IIC_0 internal latch cleared 0110: IIC_1 internal latch cleared 0111: IIC_0 and IIC_1 internal latches cleared 1---: Invalid setting When a write operation is performed on these bits, a clear signal is generated for the internal latch circuit of the corresponding module, and the internal state of the IIC module is initialized. These bits can only be written to; they are always read as 1. Write data to this bit is not retained. To perform IIC clearance, bits CLR3 to CLR0 must be written to simultaneously using an MOV instruction. Do not use a bit manipulation instruction such as BCLR. When clearing is required again, all the bits must be written to in accordance with the setting.

Note: * This bit is always read as 1.

13.3.8 I²C Bus Extended Control Register (ICXR)

ICXR enables or disables the I²C bus interface interrupt generation and continuous receive operation, and indicates the status of receive/transmit operations.

Bit	Bit Name	Initial Value	R/W	Description
7	STOPIM	0	R/W	<p>Stop Condition Interrupt Source Mask</p> <p>Enables or disables the interrupt generation when the stop condition is detected in slave mode.</p> <p>0: Enables IRIC flag setting and interrupt generation when the stop condition is detected (STOP = 1 or ESTP = 1) in slave mode.</p> <p>1: Disables IRIC flag setting and interrupt generation when the stop condition is detected.</p>
6	HNDS	0	R/W	<p>Handshake Receive Operation Select</p> <p>Enables or disables continuous receive operation in receive mode.</p> <p>0: Enables continuous receive operation</p> <p>1: Disables continuous receive operation</p> <p>When the HNDS bit is cleared to 0, receive operation is performed continuously after data has been received successfully while ICDRF flag is 0.</p> <p>When the HNDS bit is set to 1, SCL is fixed to the low level and the next data transfer is disabled after data has been received successfully while the ICDRF flag is 0. The bus line is released and next receive operation is enabled by reading the receive data in ICDR.</p>

Bit	Bit Name	Initial Value	R/W	Description
5	ICDRF	0	R	<p>Receive Data Read Request Flag</p> <p>Indicates the ICDR (ICDRR) status in receive mode.</p> <p>0: Indicates that the data has been already read from ICDR (ICDRR) or ICDR is initialized.</p> <p>1: Indicates that data has been received successfully and transferred from ICDRS to ICDRR, and the data is ready to be read out.</p> <p>[Setting conditions]</p> <ul style="list-style-type: none"> • When data is received successfully and transferred from ICDRS to ICDRR. <p>(1) When data is received successfully while ICDRF = 0 (at the rise of the 9th clock pulse).</p> <p>(2) When ICDR is read successfully in receive mode after data was received while ICDRF = 1.</p> <p>[Clearing conditions]</p> <ul style="list-style-type: none"> • When ICDR (ICDRR) is read. • When 0 is written to the ICE bit. • When the IIC is internally initialized using the CLR3 to CLR0 bits in DDCCSWR. <p>When ICDRF is set due to the condition (2) above, ICDRF is temporarily cleared to 0 when ICDR (ICDRR) is read; however, since data is transferred from ICDRS to ICDRR immediately, ICDRF is set to 1 again.</p> <p>Note that ICDR cannot be read successfully in transmit mode (TRS = 1) because data is not transferred from ICDRS to ICDRR. Be sure to read data from ICDR in receive mode (TRS = 0).</p>

Bit	Bit Name	Initial Value	R/W	Description
4	ICDRE	0	R	<p>Transmit Data Write Request Flag</p> <p>Indicates the ICDR (ICDRT) status in transmit mode.</p> <p>0: Indicates that the data has been already written to ICDR (ICDRT) or ICDR is initialized.</p> <p>1: Indicates that data has been transferred from ICDRT to ICDRS and is being transmitted, or the start condition has been detected or transmission has been complete, thus allowing the next data to be written to.</p> <p>[Setting conditions]</p> <ul style="list-style-type: none"> • When the start condition is detected from the bus line state with I²C bus format or serial format. • When data is transferred from ICDRT to ICDRS. <ol style="list-style-type: none"> 1. When data transmission completed while ICDRE = 0 (at the rise of the 9th clock pulse). 2. When data is written to ICDR in transmit mode after data transmission was completed while ICDRE = 1. <p>[Clearing conditions]</p> <ul style="list-style-type: none"> • When data is written to ICDR (ICDRT). • When the stop condition is detected with I²C bus format or serial format. • When 0 is written to the ICE bit. • When the IIC is internally initialized using the CLR3 to CLR0 bits in DDCCSWR. <p>Note that if the ACKE bit is set to 1 with I²C bus format thus enabling acknowledge bit decision, ICDRE is not set when data transmission is completed while the acknowledge bit is 1.</p> <p>When ICDRE is set due to the condition (2) above, ICDRE is temporarily cleared to 0 when data is written to ICDR (ICDRT); however, since data is transferred from ICDRT to ICDRS immediately, ICDRE is set to 1 again. Do not write data to ICDR when TRS = 0 because the ICDRE flag value is invalid during the time.</p>

Bit	Bit Name	Initial Value	R/W	Description
3	ALIE	0	R/W	<p>Arbitration Lost Interrupt Enable</p> <p>Enables or disables IRIC flag setting and interrupt generation when arbitration is lost.</p> <p>0: Disables interrupt request when arbitration is lost.</p> <p>1: Enables interrupt request when arbitration is lost.</p>
2	ALSL	0	R/W	<p>Arbitration Lost Condition Select</p> <p>Selects the condition under which arbitration is lost.</p> <p>0: When the SDA pin state disagrees with the data that IIC bus interface outputs at the rise of SCL, or when the SCL pin is driven low by another device.</p> <p>1: When the SDA pin state disagrees with the data that IIC bus interface outputs at the rise of SCL, or when the SDA line is driven low by another device in idle state or after the start condition instruction was executed.</p>
1	FNC1	0	R/W	Function Bit
0	FNC0	0	R/W	<p>Cancels some restrictions on usage. For details, see section 13.6, Usage Notes.</p> <p>00: Restrictions on operation remaining in effect</p> <p>01: Setting prohibited</p> <p>10: Setting prohibited</p> <p>11: Restrictions on operation canceled</p>

13.3.9 Port G Control Register (PGCTL)

PGCTL selects the input/output pin for IIC.

Bit	Bit Name	Initial Value	R/W	Description
7	IIC1BS	0	R/W	IIC_1 Input/Output Select B, A
6	IIC1AS	0	R/W	Selects input/output pins for IIC_1 channel
	IIC1BS	IIC1AS		
	0	0:		Selects P42/SDA1 and P86/SCL1 as IIC_1 I/O pins
	0	1:		Selects PG4/ExSDAA and PG5/ExSCLA as IIC_1 I/O pins* ¹
	1	0:		Selects PG6/ExSDAB and PG7/ExSCLB as IIC_1 I/O pins* ¹
	1	1:		Setting prohibited* ²
4, 5	—	All 0	R/W	Reserved The initial value should not be changed.
3	IIC0BS	0	R/W	IIC_0 Input/Output Select B, A
2	IIC0AS	0	R/W	Selects input/output pins for IIC_1 channel
	IIC0BS	IIC0AS		
	0	0:		Selects P97/SDA0 and P52/SCL0 as IIC_0 I/O pins
	0	1:		Selects PG4/ExSDAA and PG5/ExSCLA as IIC_0 I/O pins* ¹
	1	0:		Selects PG6/ExSDAB and PG7/ExSCLB as IIC_0 I/O pins* ¹
	1	1:		Setting prohibited* ²
1, 0	—	All 0	R/W	Reserved The initial value should not be changed.

- Notes:
1. The program development tool (emulator) does not support this function.
 2. If multiple pins are selected as the serial clock I/O pin or serial data I/O pin for each channel, the operation is not guaranteed. If a single pin is selected for both channels at the same time, the operation is not guaranteed. When pins are switched, the I²C bus must be free.

13.4 Operation

The I²C bus interface has an I²C bus format and a serial format.

13.4.1 I²C Bus Data Format

The I²C bus format is an addressing format with an acknowledge bit. This is shown in figure 13.3. The first frame following a start condition always consists of 9 bits.

The serial format is a non-addressing format with no acknowledge bit. This is shown in figure 13.4.

Figure 13.5 shows the I²C bus timing.

The symbols used in figures 13.3 to 13.5 are explained in table 13.6.

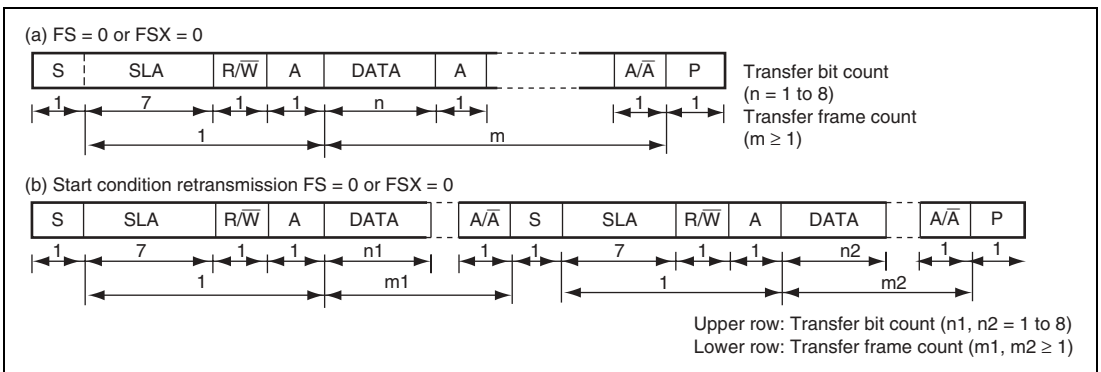

Figure 13.3 I²C Bus Data Format (I²C Bus Format)

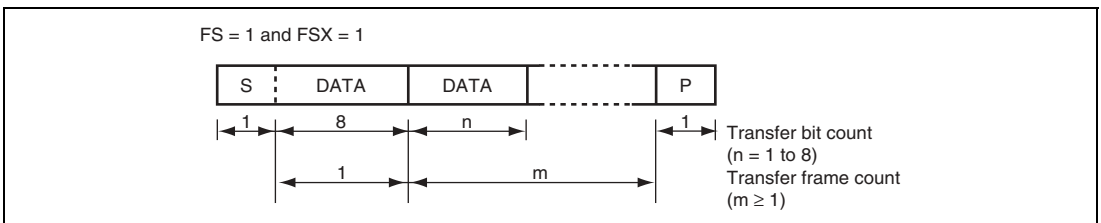

Figure 13.4 I²C Bus Data Format (Serial Format)

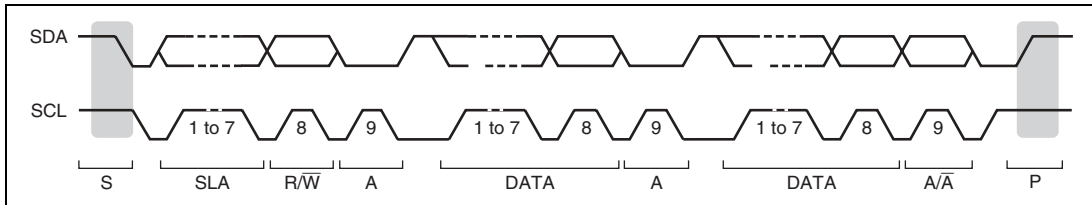

Figure 13.5 I²C Bus Timing

Table 13.6 I²C Bus Data Format Symbols

Legend

S	Start condition. The master device drives SDA from high to low while SCL is high.
SLA	Slave address. The master device selects the slave device.
R/W	Indicates the direction of data transfer: from the slave device to the master device when R/W is 1, or from the master device to the slave device when R/W is 0
A	Acknowledge. The receiving device drives SDA low to acknowledge a transfer. (The slave device returns acknowledge in master transmit mode, and the master device returns acknowledge in master receive mode.)
DATA	Transferred data. The bit length of transferred data is set with the BC2 to BC0 bits in ICMR. The MSB first or LSB first is switched with the MLS bit in ICMR.
P	Stop condition. The master device drives SDA from low to high while SCL is high.

13.4.2 Initialization

Initialize the IIC by the procedure shown in figure 13.6 before starting transmission/reception of data.

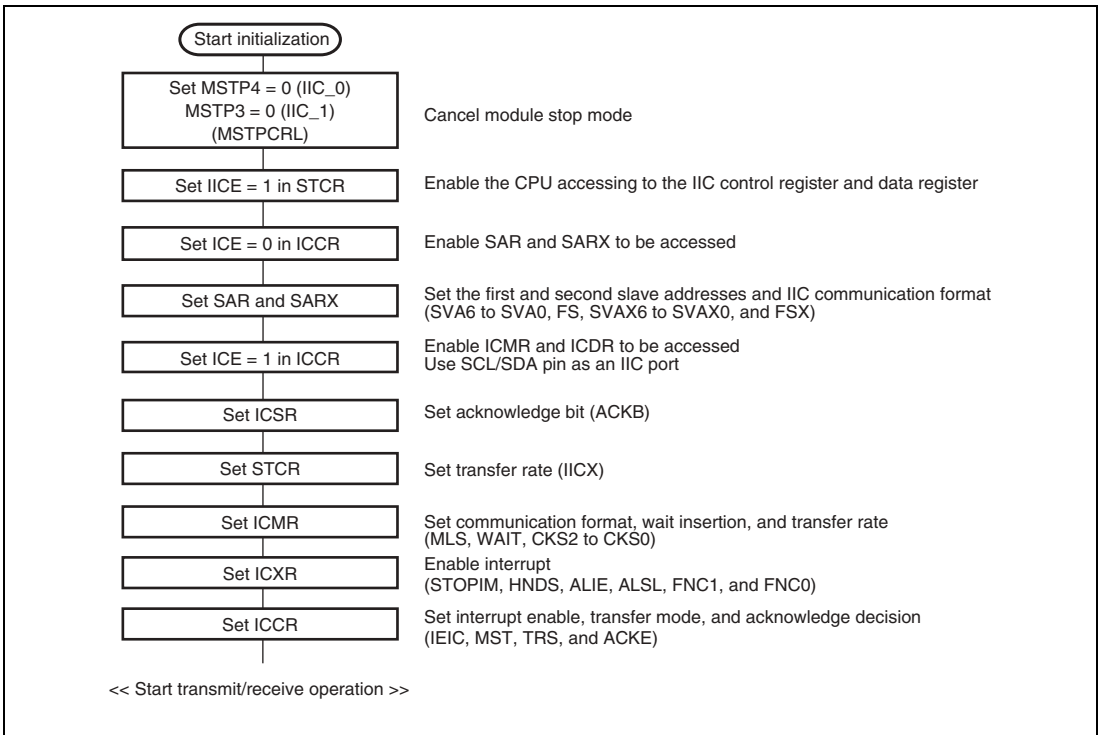

Figure 13.6 Sample Flowchart for IIC Initialization

Note: Be sure to modify ICMR after transmit/receive operation has been completed. If ICMR is modified during transmit/receive operation, bit counter BC2 to BC0 will be modified erroneously, thus causing incorrect operation.

13.4.3 Master Transmit Operation

In I²C bus format master transmit mode, the master device outputs the transmit clock and transmit data, and the slave device returns an acknowledge signal.

Figure 13.7 shows the sample flowchart for the operations in master transmit mode.

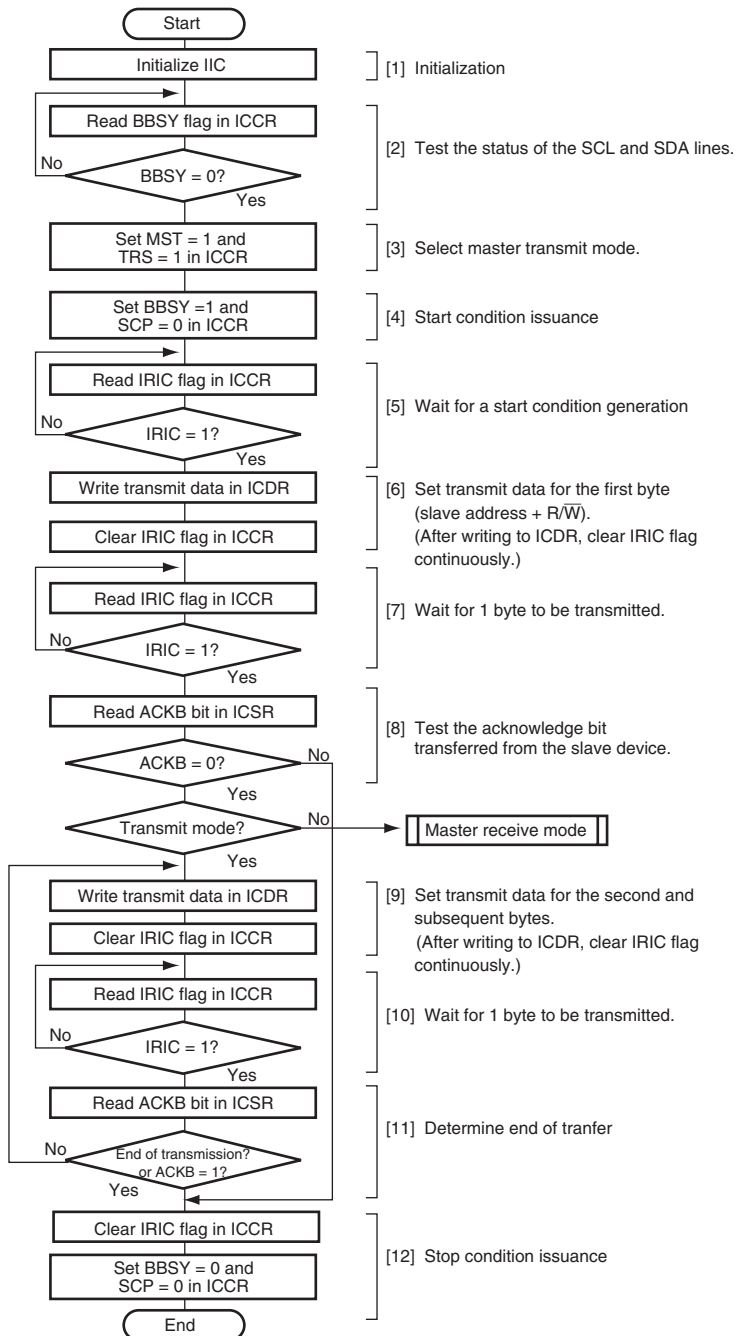

Figure 13.7 Sample Flowchart for Operations in Master Transmit Mode

The transmission procedure and operations by which data is sequentially transmitted in synchronization with ICDR (ICDRT) write operations, are described below.

1. Initialize the IIC as described in section 13.4.2, Initialization.
2. Read the BBSY flag in ICCR to confirm that the bus is free.
3. Set bits MST and TRS to 1 in ICCR to select master transmit mode.
4. Write 1 to BBSY and 0 to SCP in ICCR. This changes SDA from high to low when SCL is high, and generates the start condition.
5. Then the IRIC and IRTR flags are set to 1. If the IEIC bit in ICCR has been set to 1, an interrupt request is sent to the CPU.
6. Write the data (slave address + R/\overline{W}) to ICDR.

With the I²C bus format (when the FS bit in SAR or the FSX bit in SARX is 0), the first frame data following the start condition indicates the 7-bit slave address and transmit/receive direction (R/\overline{W}).

To determine the end of the transfer, the IRIC flag is cleared to 0. After writing to ICDR, clear IRIC continuously so no other interrupt handling routine is executed. If the time for transmission of one frame of data has passed before the IRIC clearing, the end of transmission cannot be determined. The master device sequentially sends the transmission clock and the data written to ICDR. The selected slave device (i.e. the slave device with the matching slave address) drives SDA low at the 9th transmit clock pulse and returns an acknowledge signal.

7. When one frame of data has been transmitted, the IRIC flag is set to 1 at the rise of the 9th transmit clock pulse. After one frame has been transmitted, SCL is automatically fixed low in synchronization with the internal clock until the next transmit data is written.
8. Read the ACKB bit in ICSR to confirm that ACKB is cleared to 0. When the slave device has not acknowledged (ACKB bit is 1), operate step [12] to end transmission, and retry the transmit operation.
9. Write the transmit data to ICDR.

As indicating the end of the transfer, the IRIC flag is cleared to 0. Perform the ICDR write and the IRIC flag clearing sequentially, just as in step [6]. Transmission of the next frame is performed in synchronization with the internal clock.

10. When one frame of data has been transmitted, the IRIC flag is set to 1 at the rise of the 9th transmit clock pulse. After one frame has been transmitted, SCL is automatically fixed low in synchronization with the internal clock until the next transmit data is written.
11. Read the ACKB bit in ICSR.

Confirm that the slave device has been acknowledged (ACKB bit is 0). When there is still data to be transmitted, go to step [9] to continue the next transmission operation. When the slave device has not acknowledged (ACKB bit is set to 1), operate step [12] to end transmission.

12. Clear the IRIC flag to 0.

Write 0 to ACKE in ICCR, to clear received ACKB contents to 0.

Write 0 to BBSY and SCP in ICCR. This changes SDA from low to high when SCL is high, and generates the stop condition.

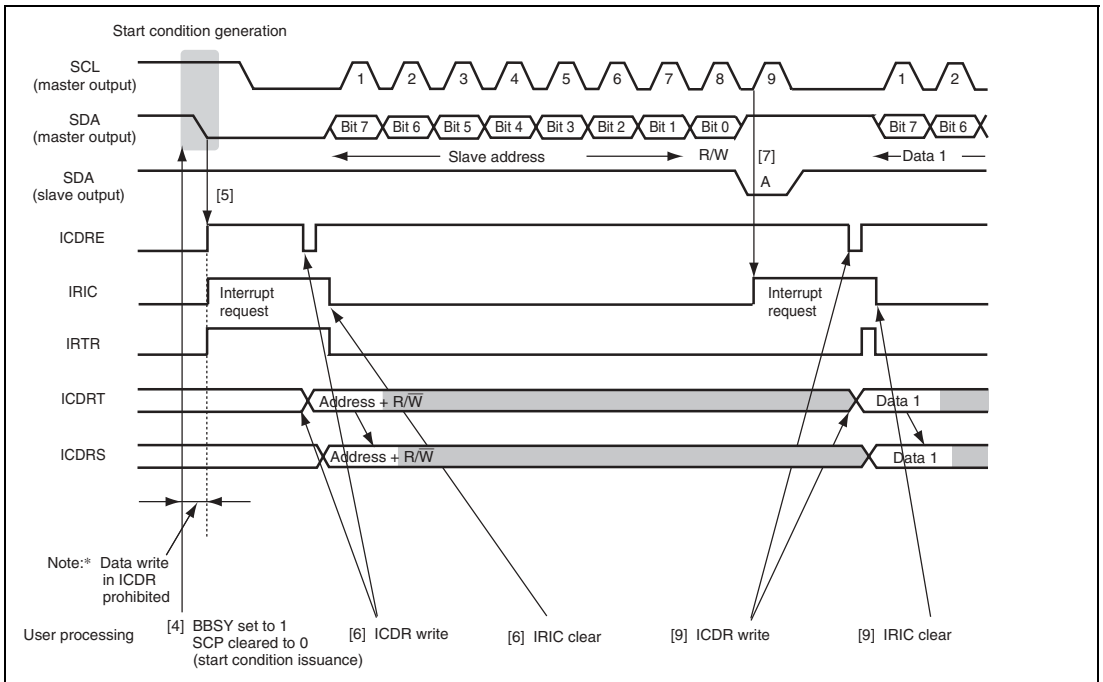

Figure 13.8 Example of Operation Timing in Master Transmit Mode (MLS = WAIT = 0)

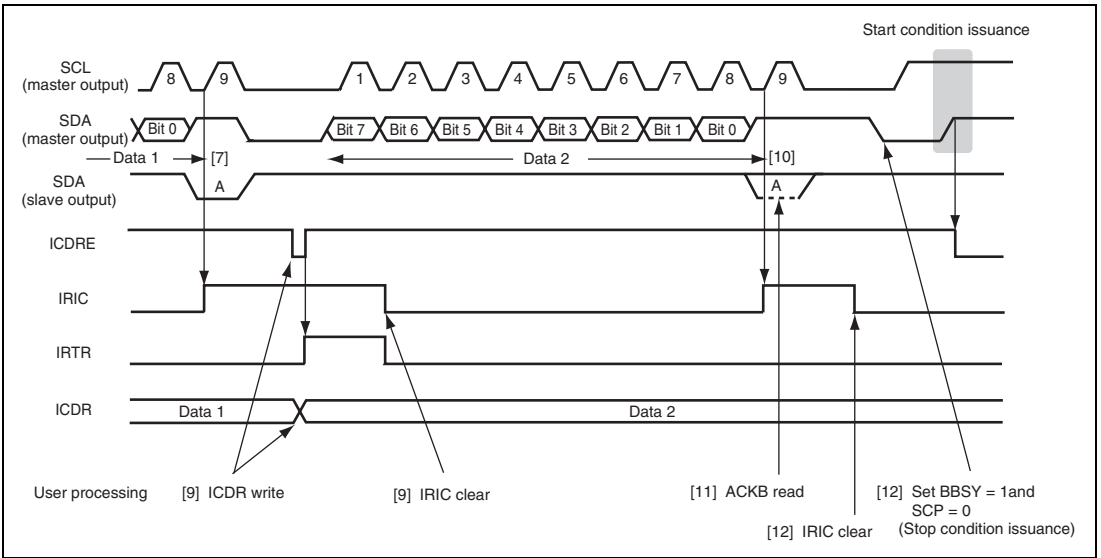

Figure 13.9 Example of Stop Condition Issuance Operation Timing in Master Transmit Mode (MLS = WAIT = 0)

13.4.4 Master Receive Operation

In I²C bus format master receive mode, the master device outputs the receive clock, receives data, and returns an acknowledge signal. The slave device transmits data.

The master device transmits data containing the slave address and R/W (1: read) in the first frame following the start condition issuance in master transmit mode, selects the slave device, and then switches the mode for receive operation.

Receive Operation Using the HNDS Function (HNDS = 1):

Figure 13.10 shows the sample flowchart for the operations in master receive mode (HNDS = 1).

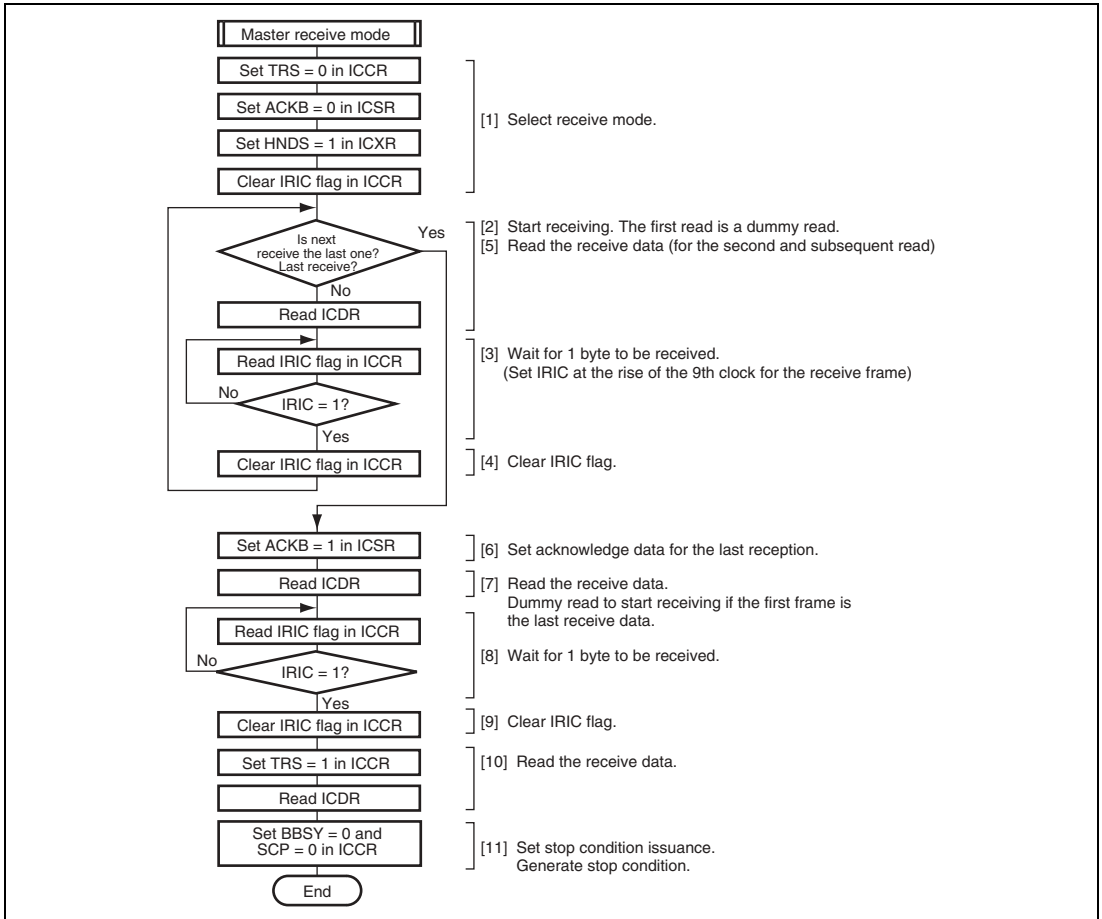

Figure 13.10 Sample Flowchart for Operations in Master Receive Mode (HNDS = 1)

The reception procedure and operations using the HNDS function, by which the data reception process is provided in 1-byte units with SCL fixed low at each data reception, are described below.

1. Clear the TRS bit in ICCR to 0 to switch from transmit mode to receive mode.
Clear the ACKB bit in ICSR to 0 (acknowledge data setting).
Set the HNDS bit in ICXR to 1.
Clear the IRIC flag to 0 to determine the end of reception.
Go to step [6] to halt reception operation if the first frame is the last receive data.
2. When ICDR is read (dummy data read), reception is started, the receive clock is output in synchronization with the internal clock, and data is received. (Data from the SDA pin is sequentially transferred to ICDRS in synchronization with the rise of the receive clock pulses.)
3. The master device drives SDA low to return the acknowledge data at the 9th receive clock pulse. The receive data is transferred from ICDRS to ICDRR at the rise of the 9th clock pulse, setting the ICDRF, IRIC, and IRTR flags to 1. If the IEIC bit has been set to 1, an interrupt request is sent to the CPU.
The master device drives SCL low from the fall of the 9th receive clock pulse to the ICDR data reading.
4. Clear the IRIC flag to clear the wait state.
Go to step [6] to halt reception operation if the next frame is the last receive data.
5. Read ICDR receive data. This clears the ICDRF flag to 0. The master device outputs the receive clock continuously to receive the next data.

Data can be received continuously by repeating steps [3] to [5].

6. Set the ACKB bit to 1 so as to return the acknowledge data for the last reception.
7. Read ICDR receive data. This clears the ICDRF flag to 0. The master device outputs the receive clock to receive data.
8. When one frame of data has been received, the ICDRF, IRIC, and IRTR flags are set to 1 at the rise of the 9th receive clock pulse.
9. Clear the IRIC flag to 0.
10. Read ICDR receive data after setting the TRS bit. This clears the ICDRF flag to 0.
11. Clear the BBSY bit and SCP bit to 0 in ICCR. This changes SDA from low to high when SCL is high, and generates the stop condition.

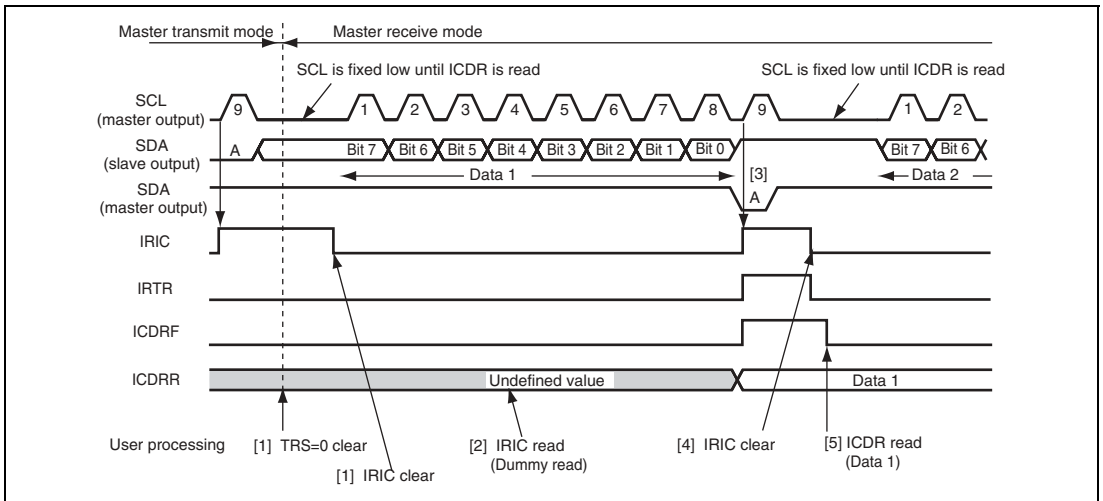

Figure 13.11 Example of Operation Timing in Master Receive Mode (MLS = WAIT = 0, HNDS = 1)

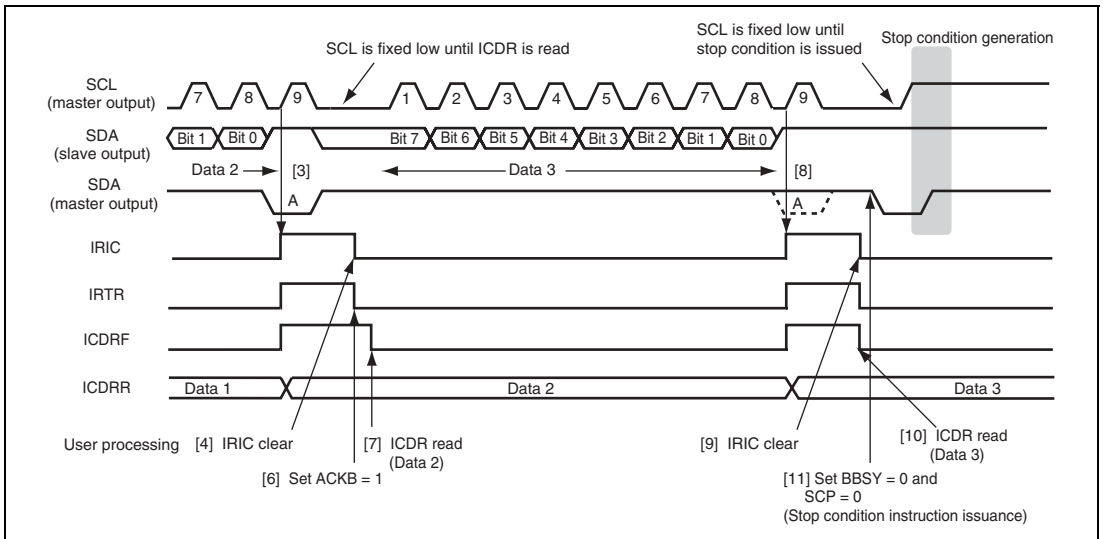

Figure 13.12 Example of Stop Condition Issuance Operation Timing in Master Receive Mode (MLS = WAIT = 0, HNDS = 1)

Receive Operation Using the Wait Function:

Figures 13.13 and 13.14 show the sample flowcharts for the operations in master receive mode (WAIT = 1).

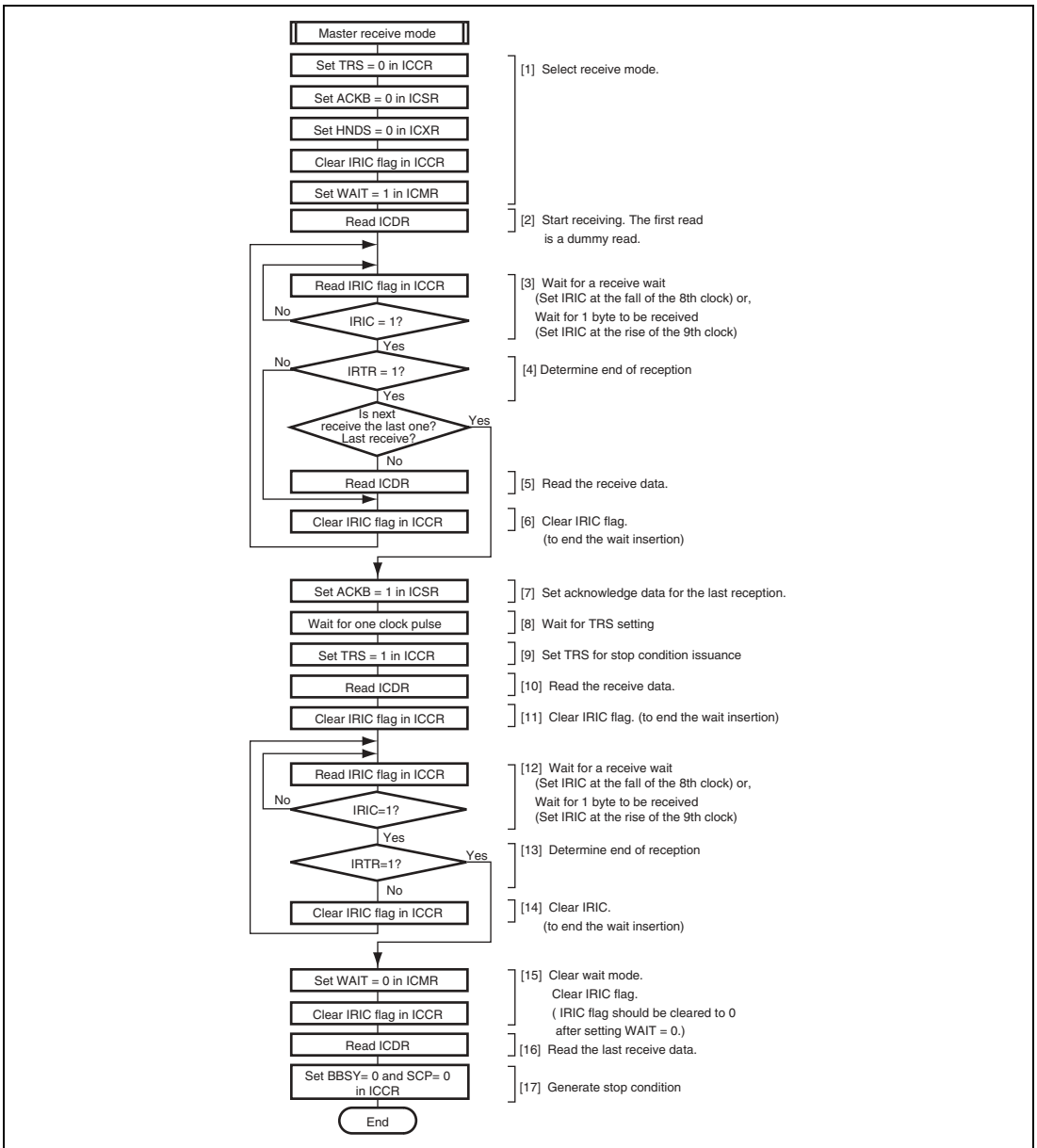

Figure 13.13 Sample Flowchart for Operations in Master Receive Mode (receiving multiple bytes) (WAIT = 1)

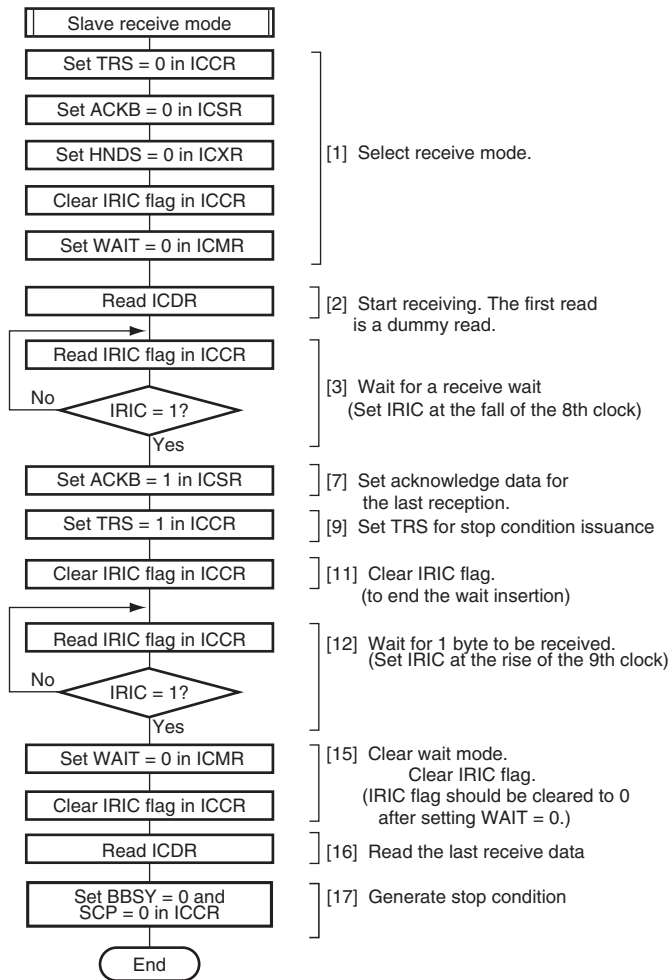

Figure 13.14 Sample Flowchart for Operations in Master Receive Mode (receiving a single byte) (WAIT = 1)

The reception procedure and operations using the wait function (WAIT bit), by which data is sequentially received in synchronization with ICDR (ICDRR) read operations, are described below.

The following describes the multiple-byte reception procedure. In single-byte reception, some steps of the following procedure are omitted. At this time, follow the procedure shown in figure 13.14.

1. Clear the TRS bit in ICCR to 0 to switch from transmit mode to receive mode.
Clear the ACKB bit in ICSR to 0 to set the acknowledge data.
Clear the HNDS bit in ICXR to 0 to cancel the handshake function.
Clear the IRIC flag to 0, and then set the WAIT bit in ICMR to 1.
2. When ICDR is read (dummy data is read), reception is started, the receive clock is output in synchronization with the internal clock, and data is received.
3. The IRIC flag is set to 1 in either of the following cases. If the IEIC bit in ICCR has been set to 1, an interrupt request is sent to the CPU.
 - At the fall of the 8th receive clock pulse for one frame
SCL is automatically fixed low in synchronization with the internal clock until the IRIC flag clearing.
 - At the rise of the 9th receive clock pulse for one frame
The IRTR and ICDRF flags are set to 1, indicating that one frame of data has been received. The master device outputs the receive clock continuously to receive the next data.
4. Read the IRTR flag in ICSR.
If the IRTR flag is 0, execute step [6] to clear the IRIC flag to 0 to release the wait state.
If the IRTR flag is 1 and the next data is the last receive data, execute step [7] to halt reception.
5. If IRTR flag is 1, read ICDR receive data.
6. Clear the IRIC flag. When the flag is set as the first case in step [3], the master device outputs the 9th clock and drives SDA low at the 9th receive clock pulse to return an acknowledge signal.

Data can be received continuously by repeating steps [3] to [6].

7. Set the ACKB bit in ICSR to 1 so as to return the acknowledge data for the last reception.
8. After the IRIC flag is set to 1, wait for at least one clock pulse until the rise of the first clock pulse for the next receive data.
9. Set the TRS bit in ICCR to 1 to switch from receive mode to transmit mode. The TRS bit value becomes valid when the rising edge of the next 9th clock pulse is input.
10. Read the ICDR receive data.
11. Clear the IRIC flag to 0.

12. The IRIC flag is set to 1 in either of the following cases.
 - At the fall of the 8th receive clock pulse for one frame
SCL is automatically fixed low in synchronization with the internal clock until the IRIC flag is cleared.
 - At the rise of the 9th receive clock pulse for one frame
The IRTR and ICDRF flags are set to 1, indicating that one frame of data has been received. The master device outputs the receive clock continuously to receive the next data.
13. Read the IRTR flag in ICSR.
If the IRTR flag is 0, execute step [14] to clear the IRIC flag to 0 to release the wait state.
If the IRTR flag is 1 and data reception is complete, execute step [15] to issue the stop condition.
14. If IRTR flag is 0, clear the IRIC flag to 0 to release the wait state.
Execute step [12] to read the IRIC flag to detect the end of reception.
15. Clear the WAIT bit in CMR to cancel the wait mode.
Then, clear the IRIC flag. Clearing of the IRIC flag should be done while WAIT = 0. (If the WAIT bit is cleared to 0 after clearing the IRIC flag and then an instruction to issue a stop condition is executed, the stop condition may not be issued correctly.)
16. Read the last ICDR receive data.
17. Clear the BBSY bit and SCP bit to 0 in ICCR. This changes SDA from low to high when SCL is high, and generates the stop condition.

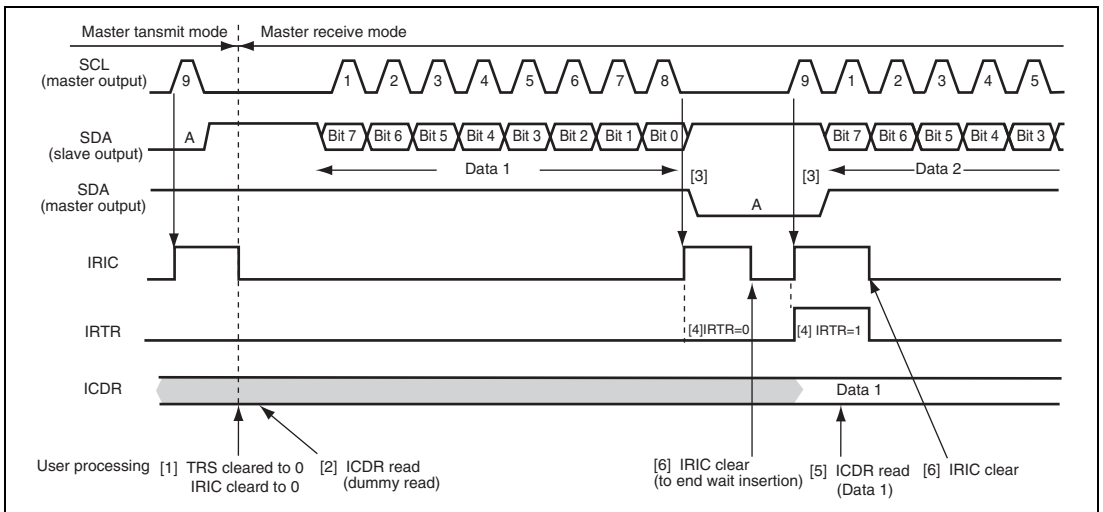

Figure 13.15 Example of Master Receive Mode Operation Timing
(MLS = ACKB = 0, WAIT = 1)

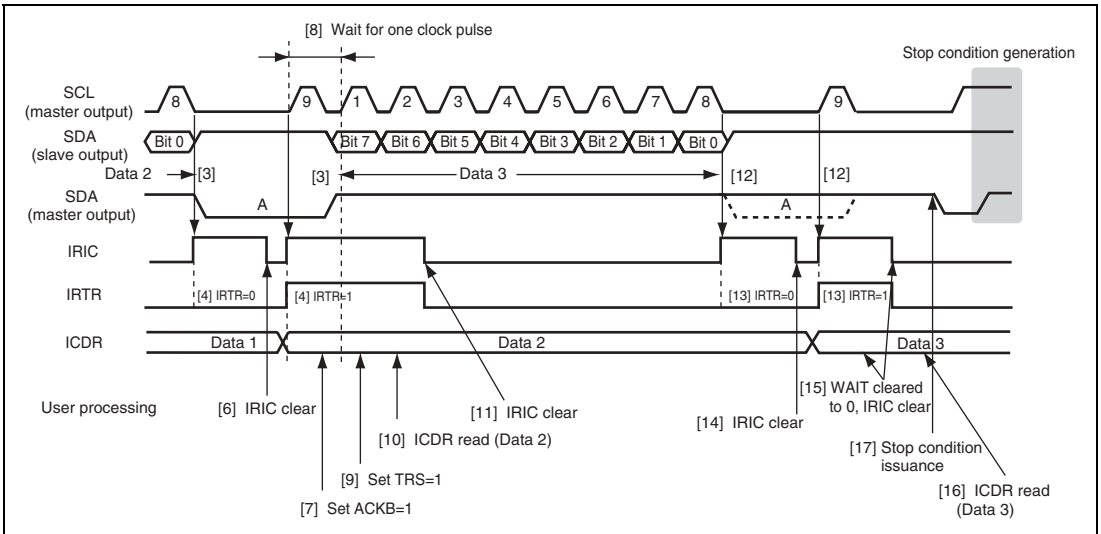

Figure 13.16 Example of Stop Condition Issuance Timing in Master Receive Mode (MLS = ACKB = 0, WAIT = 1)

13.4.5 Slave Receive Operation

In I²C bus format slave receive mode, the master device outputs the transmit clock and transmit data, and the slave device returns an acknowledge signal.

The slave device operates as the device specified by the master device when the slave address in the first frame following the start condition that is issued by the master device matches its own address.

Receive Operation Using the HNDS Function (HNDS = 1):

Figure 13.17 shows the sample flowchart for the operations in slave receive mode (HNDS = 1).

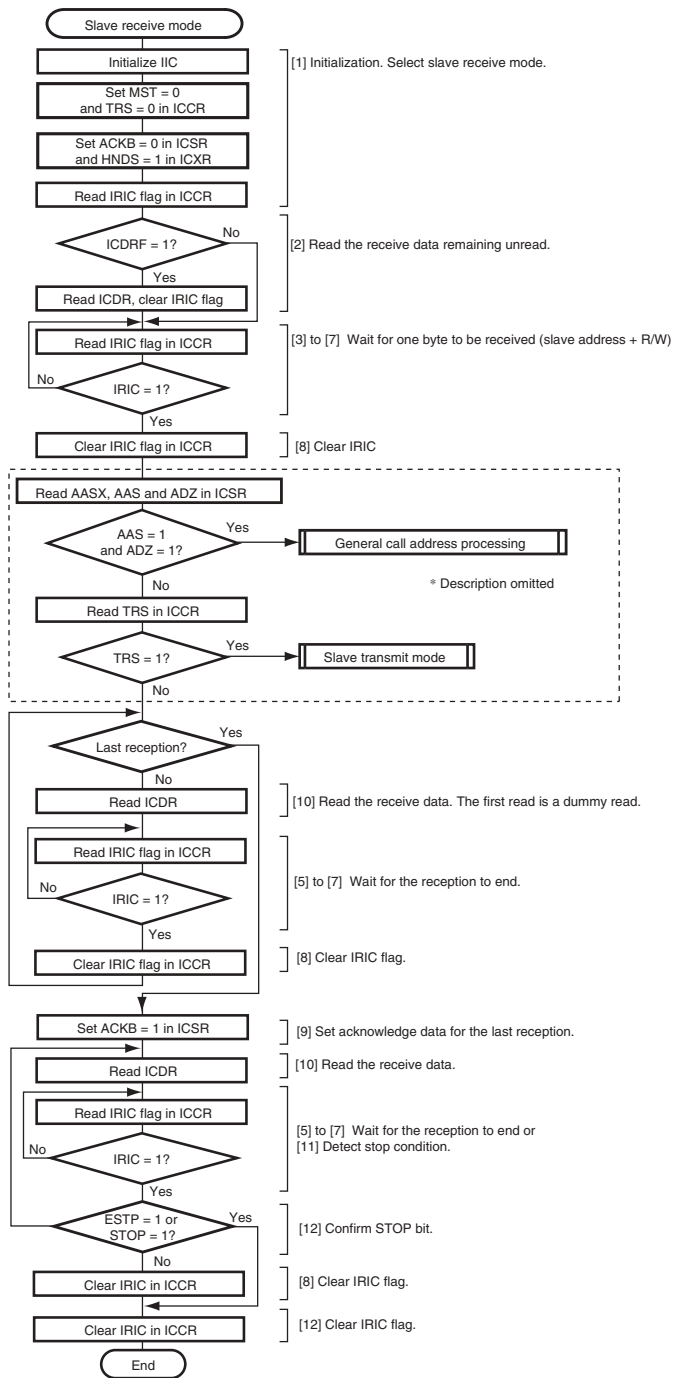

Figure 13.17 Sample Flowchart for Operations in Slave Receive Mode (HNDS = 1)

The reception procedure and operations using the HNDS bit function, by which data reception process is provided in 1-byte unit with SCL being fixed low at every data reception, are described below.

1. Initialize the IIC as described in section 13.4.2, Initialization.
Clear the MST and TRS bits to 0 to set slave receive mode, and set the HNDS bit to 1 and the ACKB bit to 0. Clear the IRIC flag in ICCR to 0 to see the end of reception.
2. Confirm that the ICDRF flag is 0. If the ICDRF flag is set to 1, read the ICDR and then clear the IRIC flag to 0.
3. When the start condition output by the master device is detected, the BBSY flag in ICCR is set to 1. The master device then outputs the 7-bit slave address and transmit/receive direction (R/W), in synchronization with the transmit clock pulses.
4. When the slave address matches in the first frame following the start condition, the device operates as the slave device specified by the master device. If the 8th data bit (R/\overline{W}) is 0, the TRS bit remains cleared to 0, and slave receive operation is performed. If the 8th data bit (R/\overline{W}) is 1, the TRS bit is set to 1, and slave transmit operation is performed. When the slave address does not match, receive operation is halted until the next start condition is detected.
5. At the 9th clock pulse of the receive frame, the slave device returns the data in the ACKB bit as an acknowledge signal.
6. At the rise of the 9th clock pulse, the IRIC flag is set to 1. If the IEIC bit has been set to 1, an interrupt request is sent to the CPU.
If the AASX bit has been set to 1, IRTR flag is also set to 1.
7. At the rise of the 9th clock pulse, the receive data is transferred from ICDRS to ICDRR, setting the ICDRF flag to 1. The slave device drives SCL low from the fall of the 9th receive clock pulse until data is read from ICDR.
8. Confirm that the STOP bit is cleared to 0, and clear the IRIC flag to 0.
9. If the next frame is the last receive frame, set the ACKB bit to 1.
10. If ICDR is read, the ICDRF flag is cleared to 0, releasing the SCL bus line. This enables the master device to transfer the next data.

Receive operations can be performed continuously by repeating steps [5] to [10].

11. When the stop condition is detected (SDA is changed from low to high when SCL is high), the BBSY flag is cleared to 0 and the STOP bit is set to 1. If the STOPIM bit has been cleared to 0, the IRIC flag is set to 1.
12. Confirm that the STOP bit is set to 1, and clear the IRIC flag to 0.

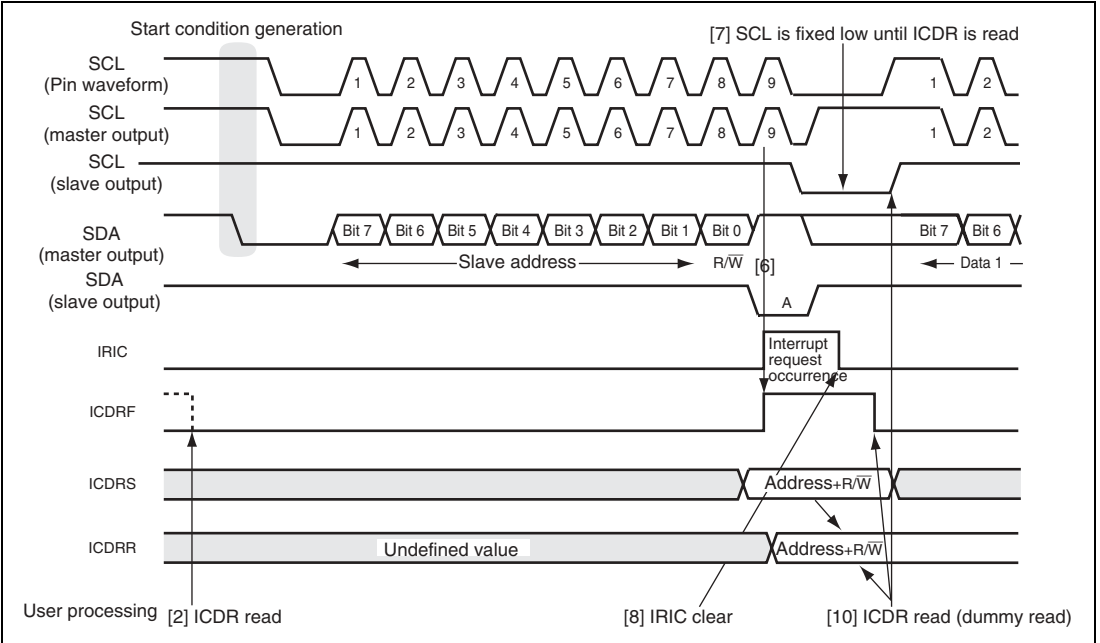

Figure 13.18 Example of Slave Receive Mode Operation Timing (1)
(MLS = 0, HNDS= 1)

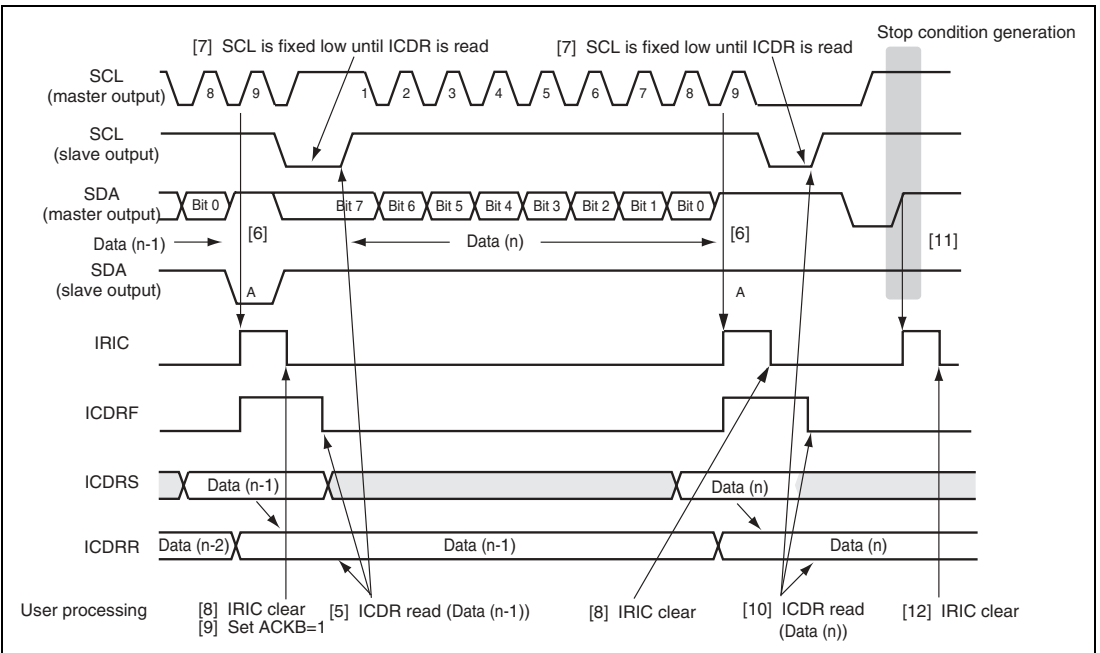

Figure 13.19 Example of Slave Receive Mode Operation Timing (2)
(MLS = 0, HNDS= 1)

Continuous Receive Operation:

Figure 13.20 shows the sample flowchart for the operations in slave receive mode (HNDS = 0).

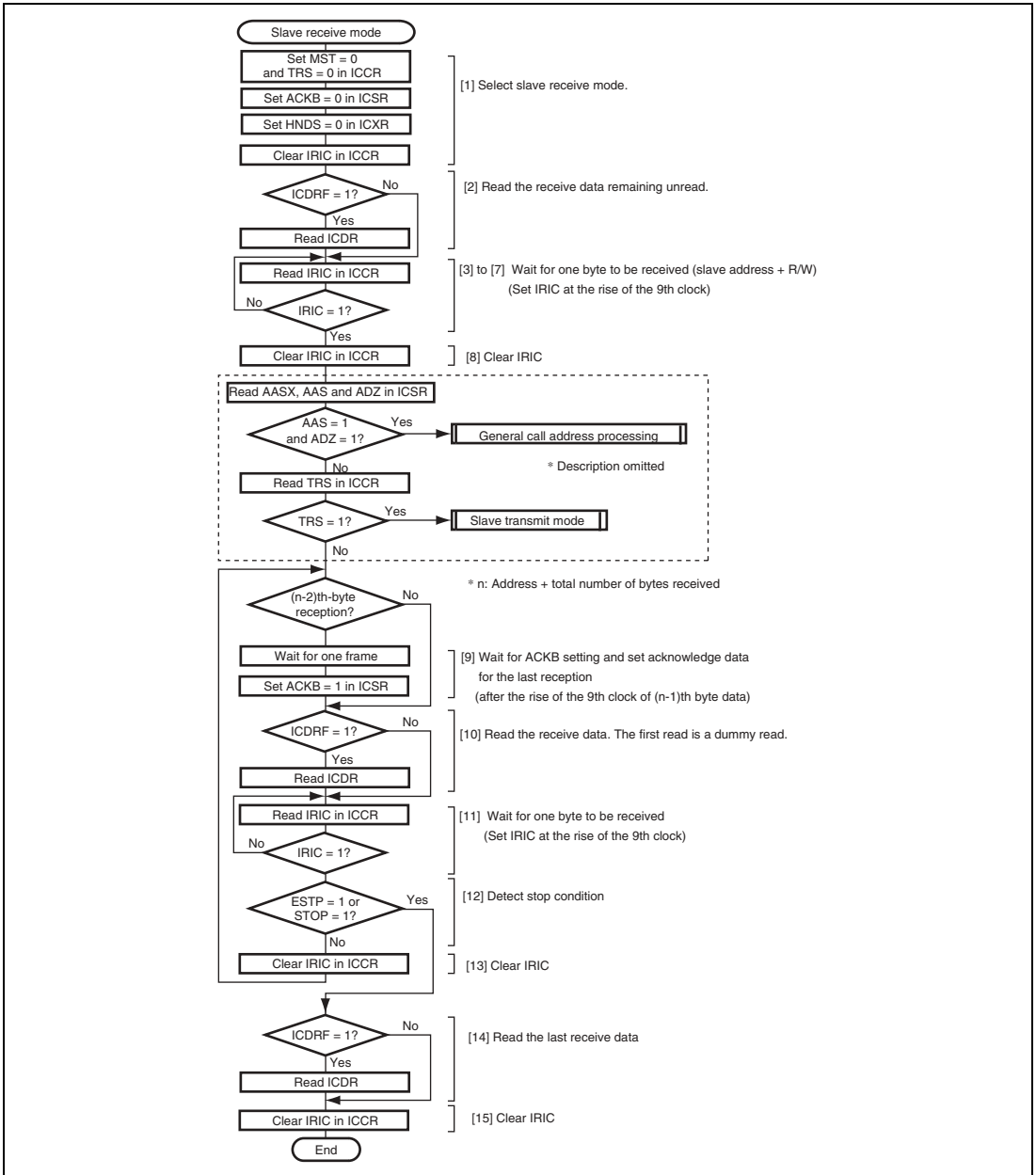

Figure 13.20 Sample Flowchart for Operations in Slave Receive Mode (HNDS = 0)

The reception procedure and operations in slave receive are described below.

1. Initialize the IIC as described in section 13.4.2, Initialization.
Clear the MST and TRS bits to 0 to set slave receive mode, and set the HNDS and ACKB bits to 0. Clear the IRIC flag in ICCR to 0 to see the end of reception.
2. Confirm that the ICDRF flag is 0. If the ICDRF flag is set to 1, read the ICDR and then clear the IRIC flag to 0.
3. When the start condition output by the master device is detected, the BBSY flag in ICCR is set to 1. The master device then outputs the 7-bit slave address and transmit/receive direction (R/W) in synchronization with the transmit clock pulses.
4. When the slave address matches in the first frame following the start condition, the device operates as the slave device specified by the master device. If the 8th data bit (R/\overline{W}) is 0, the TRS bit remains cleared to 0, and slave transmit operation is performed. When the slave address does not match, receive operation is halted until the next start condition is detected.
5. At the 9th clock pulse of the receive frame, the slave device returns the data in the ACKB bit as an acknowledge signal.
6. At the rise of the 9th clock pulse, the IRIC flag is set to 1. If the IEIC bit has been set to 1, an interrupt request is sent to the CPU.
If the AASX bit has been set to 1, the IRTR flag is also set to 1.
7. At the rise of the 9th clock pulse, the receive data is transferred from ICDRS to ICDRR, setting the ICDRF flag to 1.
8. Confirm that the STOP bit is cleared to 0 and clear the ICIC flag to 0.
9. If the next read data is the third last receive frame, wait for at least one frame time to set the ACKB bit. Set the ACKB bit after the rise of the 9th clock pulse of the second last receive frame.
10. Confirm that the ICDRF flag is set to 1 and read ICDR. This clears the ICDRF flag to 0.
11. At the rise of the 9th clock pulse or when the receive data is transferred from IRDRS to ICDRR due to ICDR read operation, the IRIC and ICDRF flags are set to 1.
12. When the stop condition is detected (SDA is changed from low to high when SCL is high), the BBSY flag is cleared to 0 and the STOP or ESTP flag is set to 1. If the STOPIM bit has been cleared to 0, the IRIC flag is set to 1. In this case, execute step [14] to read the last receive data.
13. Clear the IRIC flag to 0.

Receive operations can be performed continuously by repeating steps [9] to [13].

14. Confirm that the ICDRF flag is set to 1, and read ICDR.
15. Clear the IRIC flag.

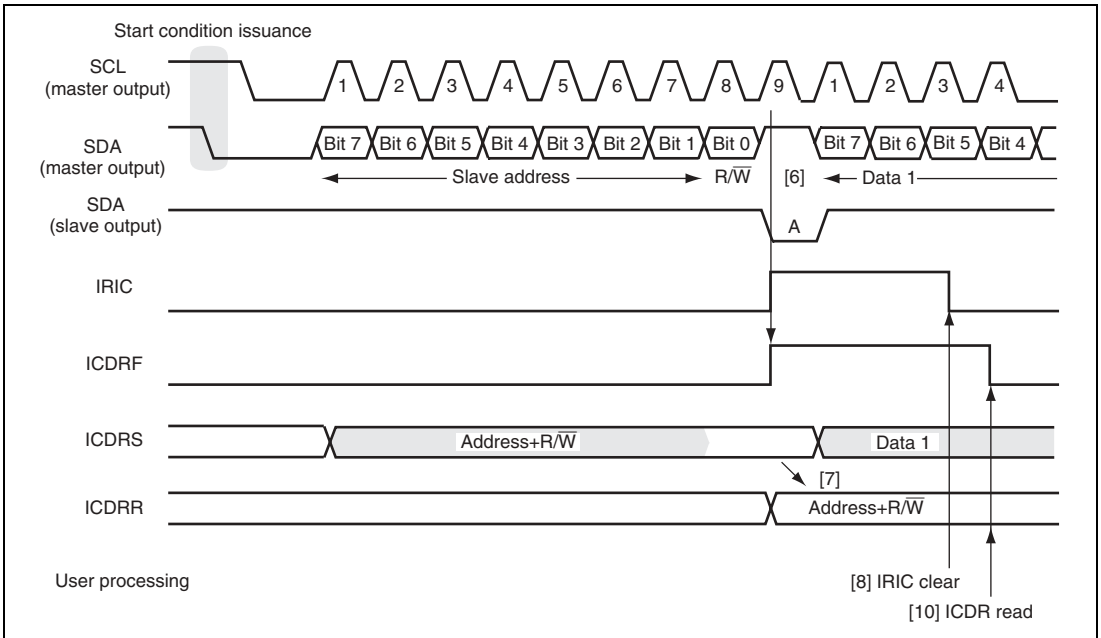

Figure 13.21 Example of Slave Receive Mode Operation Timing (1)
(MLS = ACKB = 0, HNDS = 0)

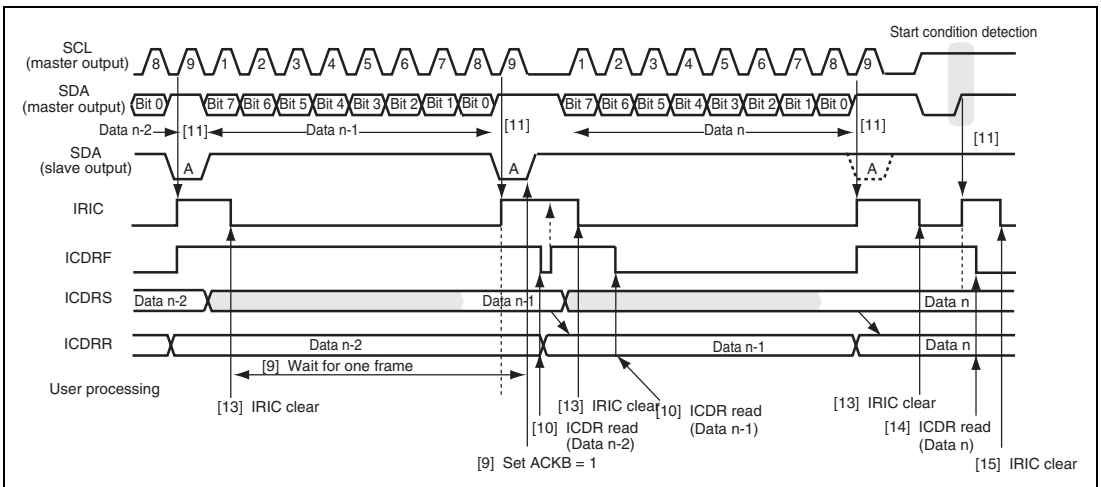

Figure 13.22 Example of Slave Receive Mode Operation Timing (2)
(MLS = ACKB = 0, HNDS = 0)

13.4.6 Slave Transmit Operation

If the slave address matches to the address in the first frame (address reception frame) following the start condition detection when the 8th bit data (R/ \bar{W}) is 1 (read), the TRS bit in ICCR is automatically set to 1 and the mode changes to slave transmit mode.

Figure 13.23 shows the sample flowchart for the operations in slave transmit mode.

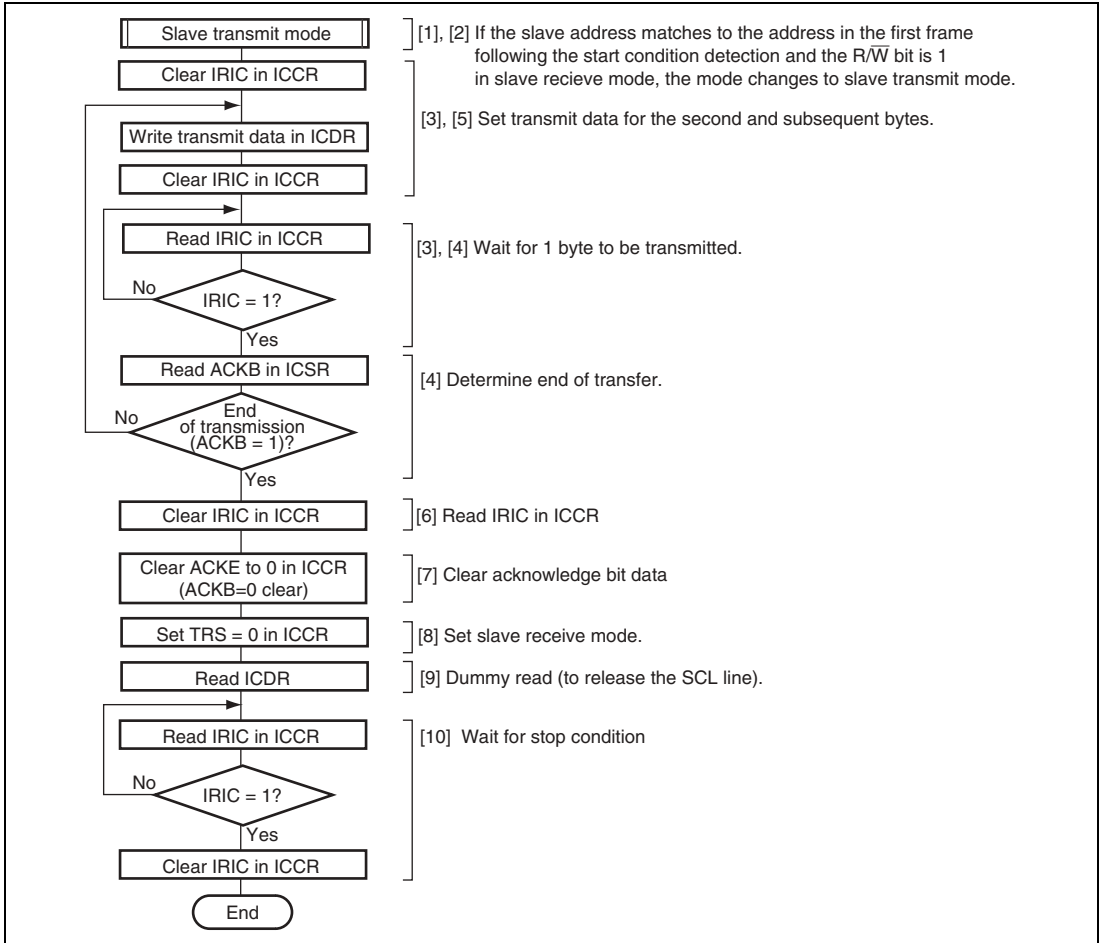

Figure 13.23 Sample Flowchart for Slave Transmit Mode

In slave transmit mode, the slave device outputs the transmit data, while the master device outputs the receive clock and returns an acknowledge signal. The transmission procedure and operations in slave transmit mode are described below.

1. Initialize slave receive mode and wait for slave address reception.
2. When the slave address matches in the first frame following detection of the start condition, the slave device drives SDA low at the 9th clock pulse and returns an acknowledge signal. If the 8th data bit (R/W) is 1, the TRS bit in ICCR is set to 1, and the mode changes to slave transmit mode automatically. The IRIC flag is set to 1 at the rise of the 9th clock. If the IEIC bit in ICCR has been set to 1, an interrupt request is sent to the CPU. At the same time, the ICDRE flag is set to 1. The slave device drives SCL low from the fall of the transmit clock until ICDR data is written, to disable the master device to output the next transfer clock.
3. After clearing the IRIC flag to 0, write data to ICDR. At this time, the ICDRE flag is cleared to 0. The written data is transferred to ICDRS, and the ICDRE and IRIC flags are set to 1 again. The slave device sequentially sends the data written into ICDRS in accordance with the clock output by the master device.

The IRIC flag is cleared to 0 to detect the end of transmission. Processing from ICDR writing to the IRIC flag clearing should be performed continuously. Prevent any other interrupt processing from being inserted.

4. The master device drives SDA low at the 9th clock pulse, and returns an acknowledge signal. As this acknowledge signal is stored in the ACKB bit in ICSR, this bit can be used to determine whether the transfer operation was performed successfully. When one frame of data has been transmitted, the IRIC flag in ICCR is set to 1 at the rise of the 9th transmit clock pulse. When the ICDRE flag is 0, the data written into ICDR is transferred to ICDRS, transmission starts, and the ICDRE and IRIC flags are set to 1 again. If the ICDRE flag has been set to 1, this slave device drives SCL low from the fall of the transmit clock until data is written to ICDR.
5. To continue transmission, write the next data to be transmitted into ICDR. The ICDRE flag is cleared to 0. The IRIC flag is cleared to 0 to detect the end of transmission. Processing from ICDR writing to the IRIC flag clearing should be performed continuously. Prevent any other interrupt processing from being inserted.

Transmit operations can be performed continuously by repeating steps [4] and [5].

6. Clear the IRIC flag to 0.
7. To end transmission, clear the ACKE bit in ICCR to 0, to clear the acknowledge bit stored in the ACKB bit to 0.
8. Clear the TRS bit to 0 for the next address reception, to set slave receive mode.
9. Dummy-read ICDR to release SDA on the slave side.

10. When the stop condition is detected, that is, when SDA is changed from low to high when SCL is high, the BBSY flag in ICCR is cleared to 0 and the STOP flag in ICSR is set to 1. When the STOPIM bit in ICXR is 0, the IRIC flag is set to 1. If the IRIC flag has been set, it is cleared to 0.

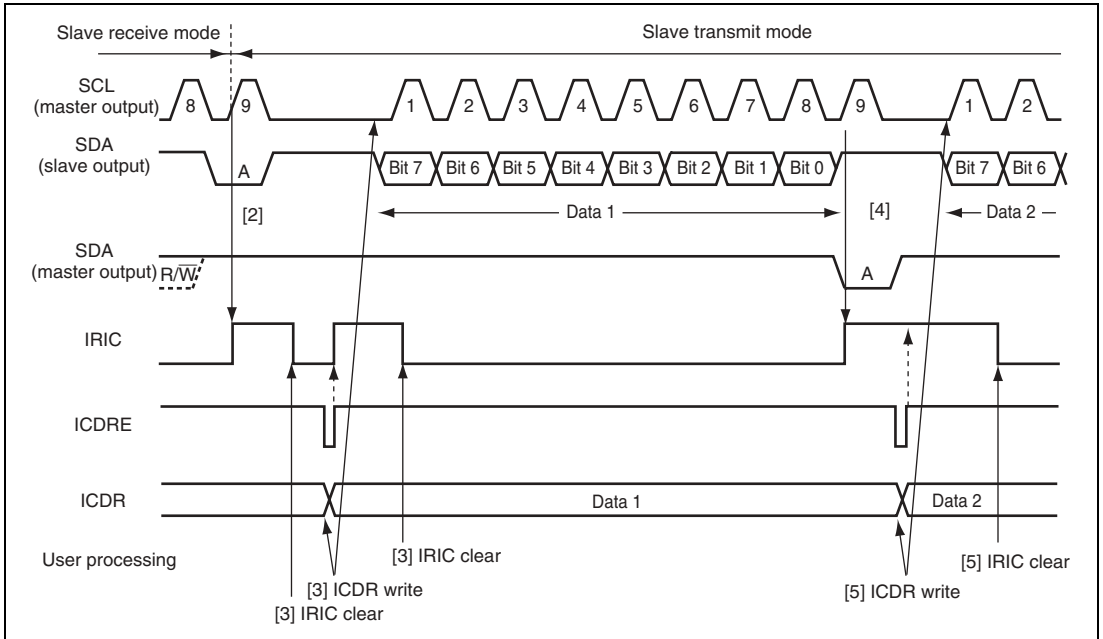

Figure 13.24 Example of Slave Transmit Mode Operation Timing (MLS = 0)

13.4.7 IRIC Setting Timing and SCL Control

The interrupt request flag (IRIC) is set at different times depending on the WAIT bit in ICMR, the FS bit in SAR, and the FSX bit in SARX. If the ICDRE or ICDRF flag is set to 1, SCL is automatically held low after one frame has been transferred in synchronization with the internal clock. Figures 13.25 to 13.27 show the IRIC set timing and SCL control.

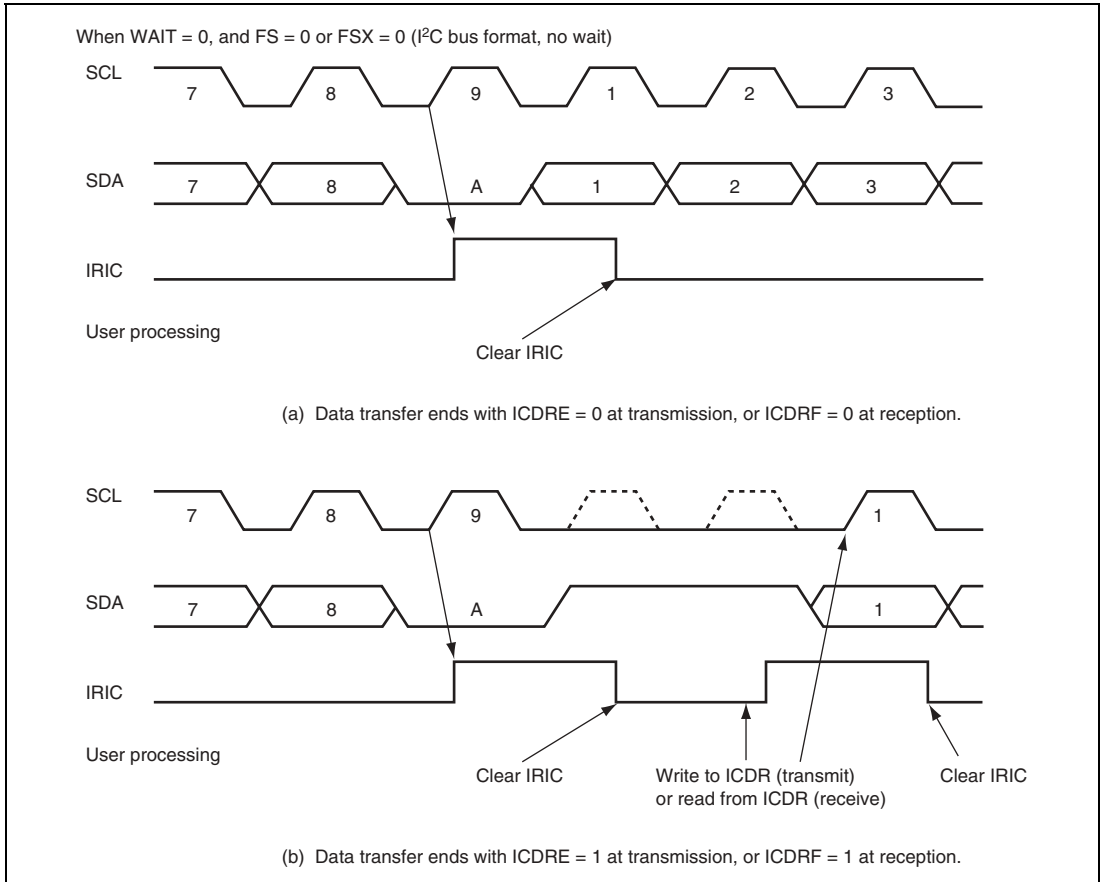
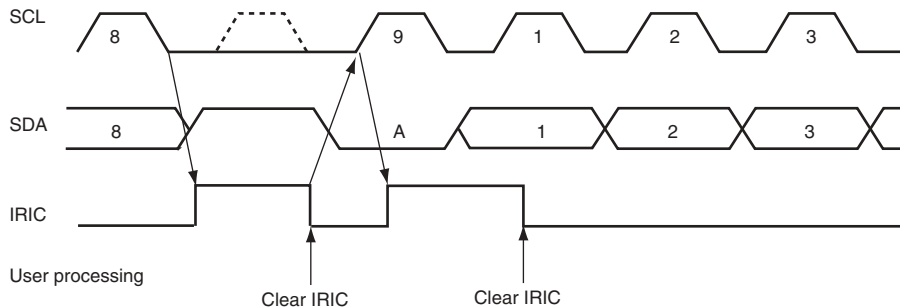
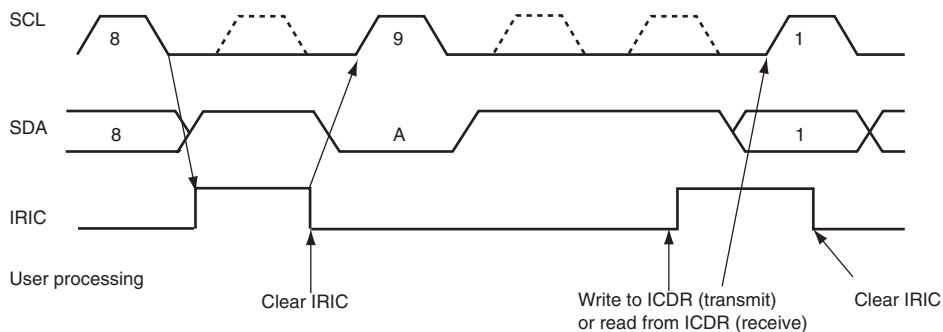

Figure 13.25 IRIC Setting Timing and SCL Control (1)

When WAIT = 1, and FS = 0 or FSX = 0 (I²C bus format, wait inserted)



(a) Data transfer ends with ICDRE=0 at transmission, or ICDRF=0 at reception.



(b) Data transfer ends with ICDRE=1 at transmission, or ICDRF=1 at reception.

Figure 13.26 IRIC Setting Timing and SCL Control (2)

When FS = 1 and FSX = 1 (clocked synchronous serial format)

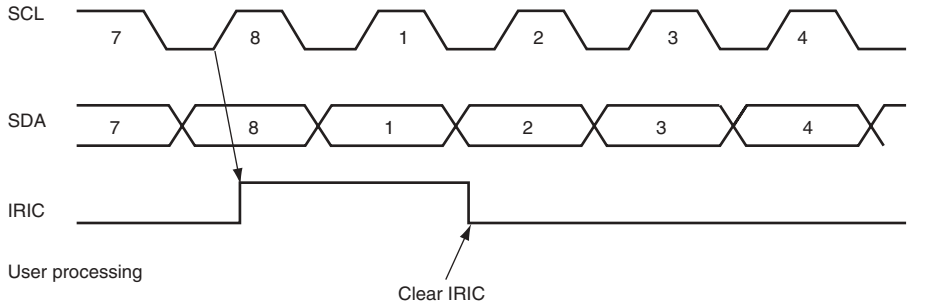

(a) Data transfer ends with ICDRE = 0 at transmission, or ICDRF = 0 at reception.

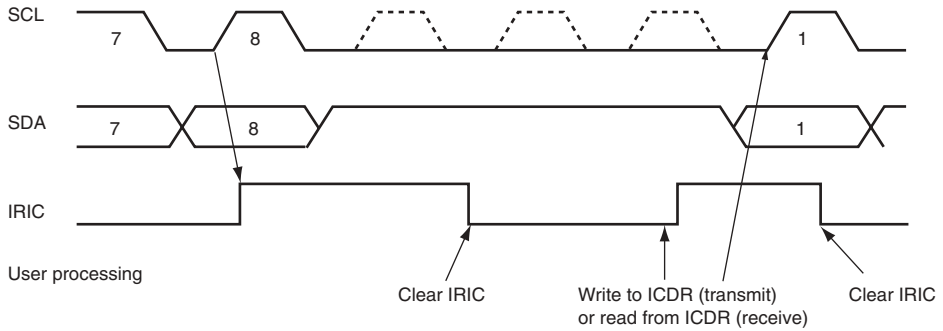

(b) Data transfer ends with ICDRE = 1 at transmission, or ICDRF = 1 at reception.

Figure 13.27 IRIC Setting Timing and SCL Control (3)

13.4.8 Noise Canceller

The logic levels at the SCL and SDA pins are routed through noise cancellers before being latched internally. Figure 13.28 shows a block diagram of the noise canceller.

The noise canceller consists of two cascaded latches and a match detector. The SCL (or SDA) pin input signal is sampled on the system clock, but is not passed forward to the next circuit unless the outputs of both latches agree. If they do not agree, the previous value is held.

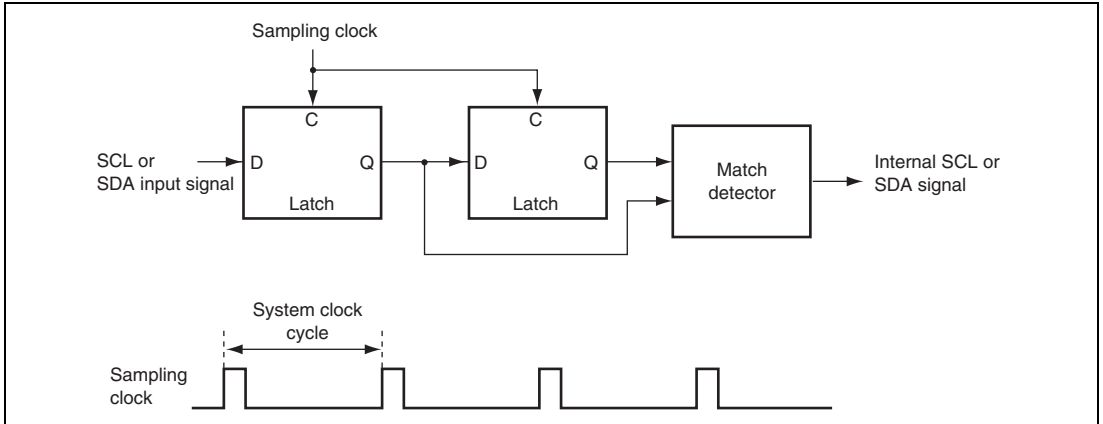

Figure 13.28 Block Diagram of Noise Canceller

13.4.9 Initialization of Internal State

The IIC has a function for forcible initialization of its internal state if a deadlock occurs during communication.

Initialization is executed in accordance with the setting of bits CLR3 to CLR0 in DDCCSWR or clearing ICE bit. For details on the setting of bits CLR3 to CLR0, see section 13.3.7, DDC Switch Register (DDCCSWR).

Scope of Initialization: The initialization executed by this function covers the following items:

- ICDRE and ICDRF internal flags
- Transmit/receive sequencer and internal operating clock counter
- Internal latches for retaining the output state of the SCL and SDA pins (wait, clock, data output, etc.)

The following items are not initialized:

- Actual register values (ICDR, SAR, SARX, ICMR, ICCR, ICSR, ICXR (except for the ICDRE and ICDRF flags), and PGCTL)
- Internal latches used to retain register read information for setting/clearing flags in ICMR, ICCR, and ICSR
- The value of the ICMR bit counter (BC2 to BC0)
- Generated interrupt sources (interrupt sources transferred to the interrupt controller)

Notes on Initialization:

- Interrupt flags and interrupt sources are not cleared, and so flag clearing measures must be taken as necessary.
- Basically, other register flags are not cleared either, and so flag clearing measures must be taken as necessary.
- When initialization is executed by DDCCSWR, the write data for bits CLR3 to CLR0 is not retained. To perform IIC clearance, bits CLR3 to CLR0 must be written to simultaneously using an MOV instruction. Do not use a bit manipulation instruction such as BCLR.
- Similarly, when clearing is required again, all the bits must be written to simultaneously in accordance with the setting.
- If a flag clearing setting is made during transmission/reception, the IIC module will stop transmitting/receiving at that point and the SCL and SDA pins will be released. When transmission/reception is started again, register initialization, etc., must be carried out as necessary to enable correct communication as a system.

The value of the BBSY bit cannot be modified directly by this module clear function, but since the stop condition pin waveform is generated according to the state and release timing of the SCL and SDA pins, the BBSY bit may be cleared as a result. Similarly, state switching of other bits and flags may also have an effect.

To prevent problems caused by these factors, the following procedure should be used when initializing the IIC state.

1. Execute initialization of the internal state according to the setting of bits CLR3 to CLR0 or ICE bit clearing.
2. Execute a stop condition issuance instruction (write 0 to BBSY and SCP) to clear the BBSY bit to 0, and wait for two transfer rate clock cycles.
3. Re-execute initialization of the internal state according to the setting of bits CLR3 to CLR0 or ICE bit clearing.
4. Initialize (re-set) the IIC registers.

13.5 Interrupt Sources

The IIC has interrupt source IICI. Table 13.7 shows the interrupt sources and priority. Individual interrupt sources can be enabled or disabled using the enable bits in ICCR, and are sent to the interrupt controller independently.

Table 13.7 IIC Interrupt Sources

Channel	Name	Enable Bit	Interrupt Source	Interrupt Flag	Priority
0	IICI0	IEIC	I ² C bus interface interrupt request	IRIC	High
1	IICI1	IEIC	I ² C bus interface interrupt request	IRIC	Low

↑
High
Low

13.6 Usage Notes

- In master mode, if an instruction to generate a start condition is issued and then an instruction to generate a stop condition is issued before the start condition is output to the I²C bus, neither condition will be output correctly. To output the start condition followed by the stop condition, after issuing the instruction that generates the start condition, read DR in each I²C bus output pin, and check that SCL and SDA are both low. The pin states can be monitored by reading DR even if the ICE bit is set to 1. Then issue the instruction that generates the stop condition. Note that SCL may not yet have gone low when BBSY is cleared to 0.
- Either of the following two conditions will start the next transfer. Pay attention to these conditions when accessing to ICDR.
 - Write to ICDR when ICE = 1 and TRS = 1 (including automatic transfer from ICDRT to ICDRS)
 - Read from ICDR when ICE = 1 and TRS = 0 (including automatic transfer from ICDRS to ICDRR)
- Table 13.8 shows the timing of SCL and SDA outputs in synchronization with the internal clock. Timings on the bus are determined by the rise and fall times of signals affected by the bus load capacitance, series resistance, and parallel resistance.

Table 13.8 I²C Bus Timing (SCL and SDA Outputs)

Item	Symbol	Output Timing	Unit	Notes
SCL output cycle time	t_{SCLO}	$28t_{cyc}$ to $256t_{cyc}$	ns	See figure
SCL output high pulse width	t_{SCLHO}	$0.5t_{SCLO}$	ns	22.22.
SCL output low pulse width	t_{SCLLO}	$0.5t_{SCLO}$	ns	
SDA output bus free time	t_{BUFO}	$0.5t_{SCLO} - 1t_{cyc}$	ns	
Start condition output hold time	t_{STAH0}	$0.5t_{SCLO} - 1t_{cyc}$	ns	
Retransmission start condition output setup time	t_{STAS0}	$1t_{SCLO}$	ns	
Stop condition output setup time	t_{STOSO}	$0.5t_{SCLO} + 2t_{cyc}$	ns	
Data output setup time (master)	t_{SDAS0}	$1t_{SCLLO} - 3t_{cyc}$	ns	
Data output setup time (slave)		$1t_{SCLL} - (6t_{cyc} \text{ or } 12t_{cyc}^*)$		
Data output hold time	t_{SDAHO}	$3t_{cyc}$	ns	

Note: * $6t_{cyc}$ when IICX is 0, $12t_{cyc}$ when 1.

- SCL and SDA inputs are sampled in synchronization with the internal clock. The AC timing therefore depends on the system clock cycle t_{cyc} , as shown in section 22, Electrical Characteristics. Note that the I²C bus interface AC timing specifications will not be met with a system clock frequency of less than 5 MHz.

5. The I²C bus interface specification for the SCL rise time t_{sr} is 1000 ns or less (300 ns for high-speed mode). In master mode, the I²C bus interface monitors the SCL line and synchronizes one bit at a time during communication. If t_{sr} (the time for SCL to go from low to V_{IH}) exceeds the time determined by the input clock of the I²C bus interface, the high period of SCL is extended. The SCL rise time is determined by the pull-up resistance and load capacitance of the SCL line. To insure proper operation at the set transfer rate, adjust the pull-up resistance and load capacitance so that the SCL rise time does not exceed the values given in table 13.9.

Table 13.9 Permissible SCL Rise Time (t_{sr}) Values

IICX	t_{cyc} Indication		Time Indication [ns]			
			I ² C Bus Specification (Max.)	$\phi = 5$ MHz	$\phi = 8$ MHz	$\phi = 10$ MHz
0	$7.5 t_{cyc}$	Standard mode	1000	1000	937	750
		High-speed mode	300	300	300	300
1	$17.5 t_{cyc}$	Standard mode	1000	1000	1000	1000
		High-speed mode	300	300	300	300

6. The I²C bus interface specifications for the SCL and SDA rise and fall times are under 1000 ns and 300 ns. The I²C bus interface SCL and SDA output timing is prescribed by t_{cyc} , as shown in table 13.8. However, because of the rise and fall times, the I²C bus interface specifications may not be satisfied at the maximum transfer rate. Table 13.10 shows output timing calculations for different operating frequencies, including the worst-case influence of rise and fall times.

t_{BUFO} fails to meet the I²C bus interface specifications at any frequency. The solution is either (a) to provide coding to secure the necessary interval (approximately 1 μ s) between issuance of a stop condition and issuance of a start condition, or (b) to select devices whose input timing permits this output timing for use as slave devices connected to the I²C bus.

t_{SCLLO} in high-speed mode and t_{STASO} in standard mode fail to satisfy the I²C bus interface specifications for worst-case calculations of t_{sr}/t_{sr} . Possible solutions that should be investigated include (a) adjusting the rise and fall times by means of a pull-up resistor and capacitive load, (b) reducing the transfer rate to meet the specifications, or (c) selecting devices whose input timing permits this output timing for use as slave devices connected to the I²C bus.

Table 13.10 I²C Bus Timing (with Maximum Influence of t_{sr}/t_{sr})

Item	t_{cyc} Indication		Time Indication (at Maximum Transfer Rate) [ns]				
			t_{sr}/t_{sr} Influence (Max.)	I ² C Bus Specifi- cation (Min.)	$\phi =$ 5 MHz	$\phi =$ 8 MHz	$\phi =$ 10 MHz
t_{SCLHO}	$0.5 t_{SCLO} (-t_{sr})$	Standard mode	-1000	4000	4000	4000	4000
		High-speed mode	-300	600	950	950	950
t_{SCLLO}	$0.5 t_{SCLO} (-t_{sr})$	Standard mode	-250	4700	4750	4750	4750
		High-speed mode	-250	1300	1000* ¹	1000* ¹	1000* ¹
t_{BUFO}	$0.5 t_{SCLO} - 1 t_{cyc}$ $(-t_{sr})$	Standard mode	-1000	4700	3800* ¹	3875* ¹	3900* ¹
		High-speed mode	-300	1300	750* ¹	825* ¹	850* ¹
t_{STAHO}	$0.5 t_{SCLO} - 1 t_{cyc}$ $(-t_{sr})$	Standard mode	-250	4000	4550	4625	4650
		High-speed mode	-250	600	800	875	900
t_{STASO}	$1 t_{SCLO} (-t_{sr})$	Standard mode	-1000	4700	9000	9000	9000
		High-speed mode	-300	600	2200	2200	2200
t_{STOSO}	$0.5 t_{SCLO} + 2 t_{cyc}$ $(-t_{sr})$	Standard mode	-1000	4000	4400	4250	4200
		High-speed mode	-300	600	1350	1200	1150
t_{SDASO} (master)	$1 t_{SCLLO}^{*3} - 3 t_{cyc}$ $(-t_{sr})$	Standard mode	-1000	250	3100	3325	3400
		High-speed mode	-300	100	400	625	700
t_{SDASO} (slave)	$1 t_{SCLL}^{*3}$ $- 12 t_{cyc}^{*2}$ $(-t_{sr})$	Standard mode	-1000	250	1300	2200	2500
		High-speed mode	-300	100	-1400* ¹	-500* ¹	-200* ¹
t_{SDAHO}	$3 t_{cyc}$	Standard mode	0	0	600	375	300
		High-speed mode	0	0	600	375	300

Notes: 1. Does not meet the I²C bus interface specification. Remedial action such as the following is necessary: (a) secure a start/stop condition issuance interval; (b) adjust the rise and fall times by means of a pull-up resistor and capacitive load; (c) reduce the transfer rate; (d) select slave devices whose input timing permits this output timing.

The values in the above table will vary depending on the settings of the IICX bit and bits CKS0 to CKS2. Depending on the frequency it may not be possible to achieve the maximum transfer rate; therefore, whether or not the I²C bus interface specifications are met must be determined in accordance with the actual setting conditions.

- Value when the IICX bit is set to 1. When the IICX bit is cleared to 0, the value is ($t_{SCLL} - 6t_{cyc}$).
- Calculated using the I²C bus specification values (standard mode: 4700 ns min.; high-speed mode: 1300 ns min.).

7. Notes on ICDR read at end of master reception

To halt reception at the end of a receive operation in master receive mode, set the TRS bit to 1 and write 0 to BBSY and SCP in ICCR. This changes SDA from low to high when SCL is high, and generates the stop condition. After this, receive data can be read by means of an ICDR read, but if data remains in the buffer the ICDRS receive data will not be transferred to ICDR (ICDRR), and so it will not be possible to read the second byte of data.

If it is necessary to read the second byte of data, issue the stop condition in master receive mode (i.e. with the TRS bit cleared to 0). When reading the receive data, first confirm that the BBSY bit in ICCR is cleared to 0, the stop condition has been generated, and the bus has been released, then read ICDR with TRS cleared to 0.

Note that if the receive data (ICDR data) is read in the interval between execution of the instruction for issuance of the stop condition (writing of 0 to BBSY and SCP in ICCR) and the actual generation of the stop condition, the clock may not be output correctly in subsequent master transmission.

Clearing of the MST bit after completion of master transmission/reception, or other modifications of IIC control bits to change the transmit/receive operating mode or settings, must be carried out during interval (a) in figure 13.29 (after confirming that the BBSY bit in ICCR has been cleared to 0).

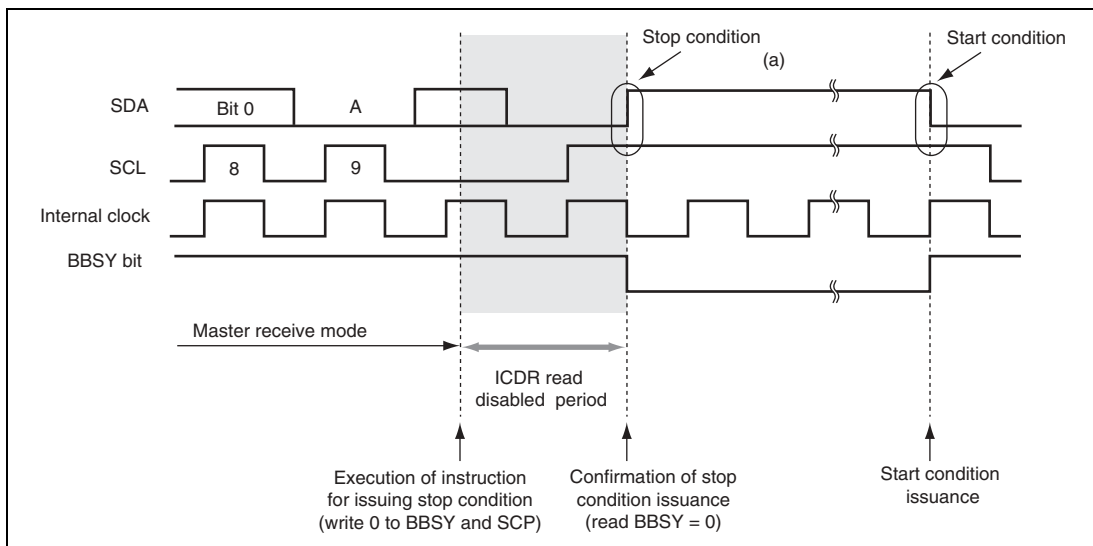

Figure 13.29 Notes on Reading Master Receive Data

Note: This restriction on usage can be canceled by setting the FNC1 and FNC0 bits to 1 in ICXR.

8. Notes on start condition issuance for retransmission

Figure 13.30 shows the timing of start condition issuance for retransmission, and the timing for subsequently writing data to ICDR, together with the corresponding flowchart. Write the transmit data to ICDR after the start condition for retransmission is issued and then the start condition is actually generated.

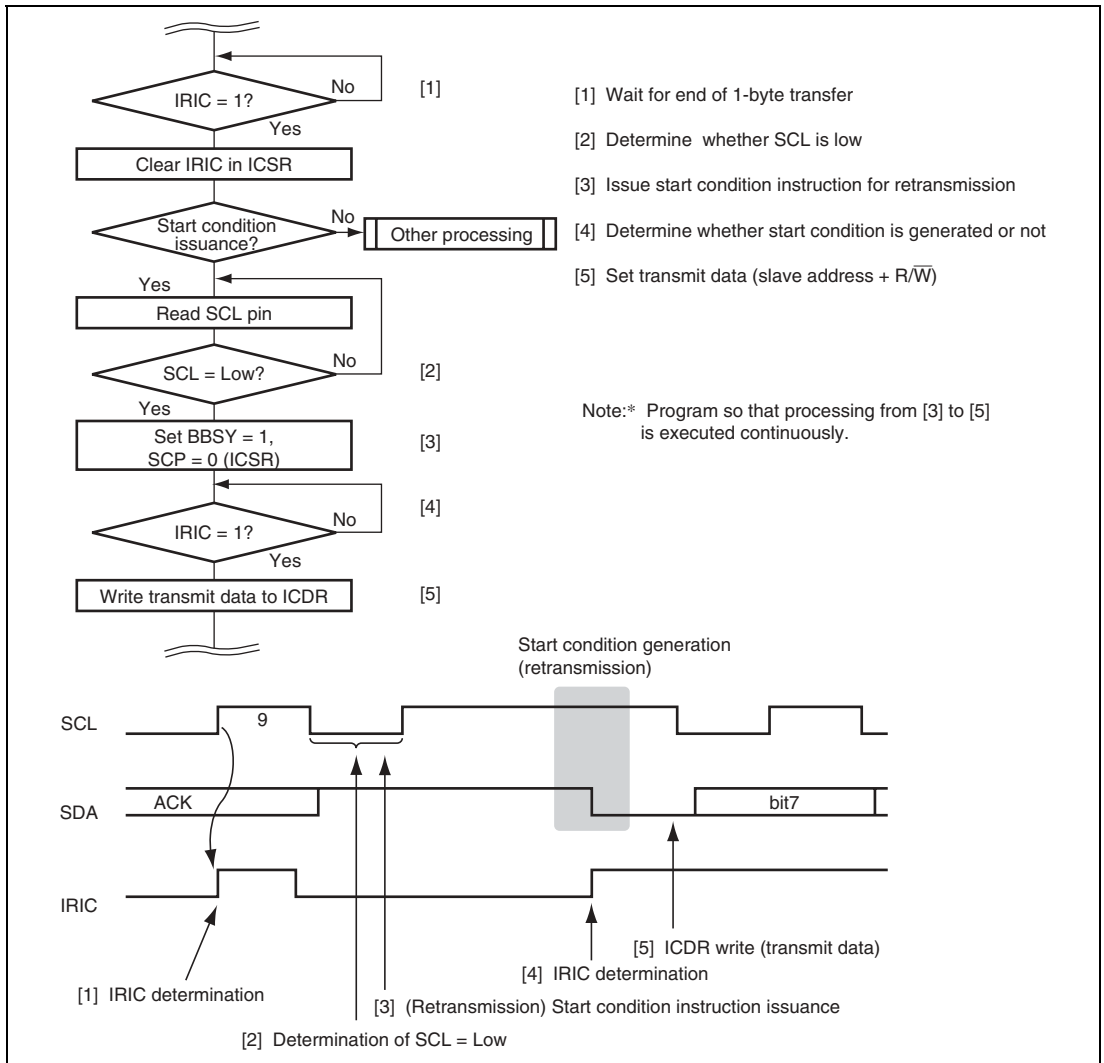

Figure 13.30 Flowchart for Start Condition Issuance Instruction for Retransmission and Timing

Note: This restriction on usage can be canceled by setting the FNC1 and FNC0 bits to 1 in ICXR.

9. Note on when I²C bus interface stop condition instruction is issued

In cases where the rise time of the 9th clock of SCL exceeds the stipulated value because of a large bus load capacity or where a slave device in which a wait can be inserted by driving the SCL pin low is used, the stop condition instruction should be issued after reading SCL after the rise of the 9th clock pulse and determining that it is low.

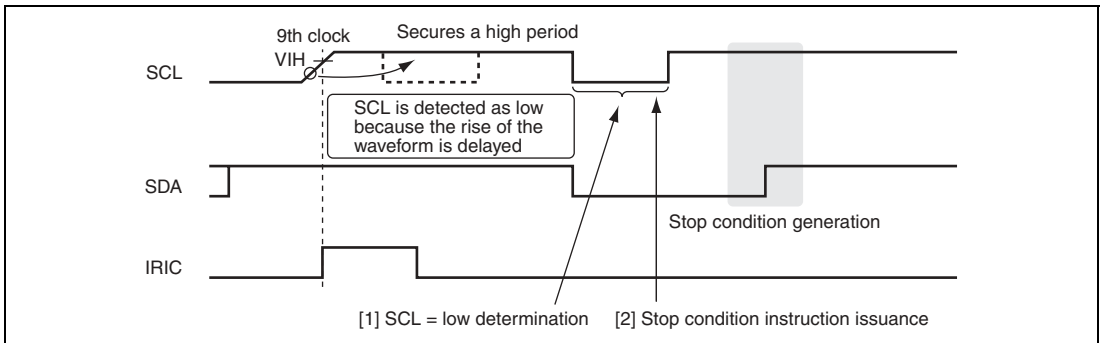

Figure 13.31 Stop Condition Issuance Timing

Note: This restriction on usage can be canceled by setting the FNC1 and FNC0 bits to 1 in ICXR.

10. Note on IRIC flag clear when the wait function is used

If the rise time of SCL exceeds the stipulated value or a slave device in which a wait can be inserted by driving the SCL pin low is used when the wait function is used in I²C bus interface master mode, the IRIC flag should be cleared after determining that the SCL is low, as described below.

If the IRIC flag is cleared to 0 when WAIT = 1 while the SCL is extending the high level time, the SDA level may change before the SCL goes low, which may generate a start or stop condition erroneously.

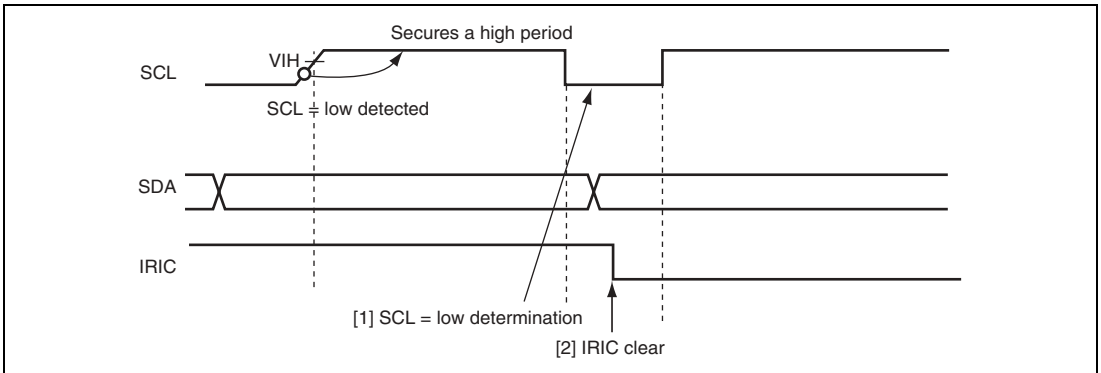

Figure 13.32 IRIC Flag Clearing Timing when WAIT = 1

Note: This restriction on usage can be canceled by setting the FNC1 and FNC0 bits to 1 in ICXR.

11. Note on ICDR read and ICCR access in slave transmit mode

In I²C bus interface slave transmit mode, do not read ICDR or do not read/write from/to ICCR during the time shaded in figure 13.33. However, such read and write operations cause no problem in interrupt handling processing that is generated in synchronization with the rising edge of the 9th clock pulse because the shaded time has passed before making the transition to interrupt handling.

To handle interrupts securely, be sure to keep either of the following conditions.

- Read ICDR data that has been received so far or read/write from/to ICCR before starting the receive operation of the next slave address.
- Monitor the BC2 to BC0 bit counter in ICMR; when the count is 000 (8th or 9th clock pulse), wait for at least two transfer clock times in order to read ICDR or read/write from/to ICCR during the time other than the shaded time.

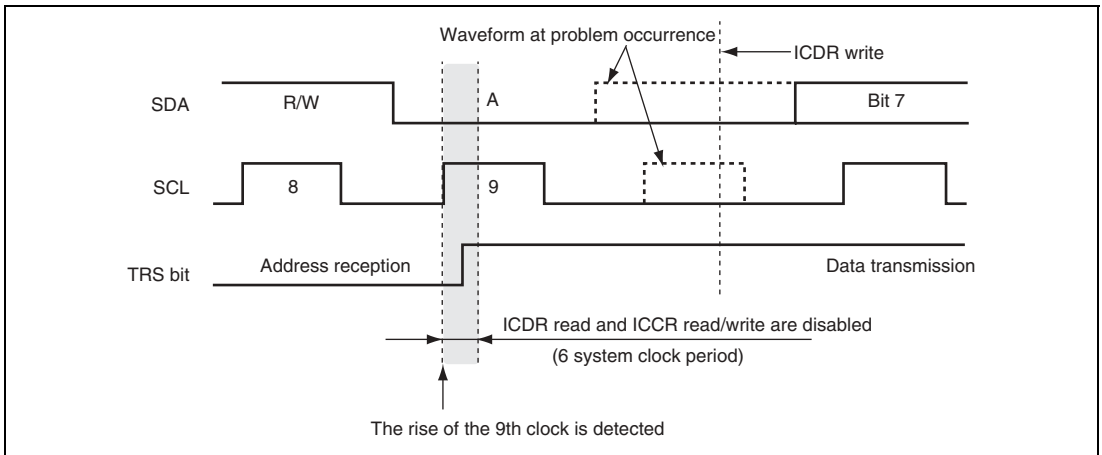

Figure 13.33 ICDR Read and ICCR Access Timing in Slave Transmit Mode

Note: This restriction on usage can be canceled by setting the FNC1 and FNC0 bits to 1 in ICMR.

12. Note on TRS bit setting in slave mode

In I²C bus interface slave mode, if the TRS bit value in ICCR is set after detecting the rising edge of the 9th clock pulse or the stop condition before detecting the next rising edge on the SCL pin (the time indicated as (a) in figure 13.34), the bit value becomes valid immediately when it is set. However, if the TRS bit is set during the other time (the time indicated as (b) in figure 13.34), the bit value is suspended and remains invalid until the rising edge of the 9th clock pulse or the stop condition is detected. Therefore, when the address is received after the restart condition is input without the stop condition, the effective TRS bit value remains 1 (transmit mode) internally and thus the acknowledge bit is not transmitted after the address has been received at the 9th clock pulse.

To receive the address in slave mode, clear the TRS bit to 0 during the time indicated as (a) in figure 13.34. To release the SCL low level that is held by means of the wait function in slave mode, clear the TRS bit to and then dummy-read ICDR.

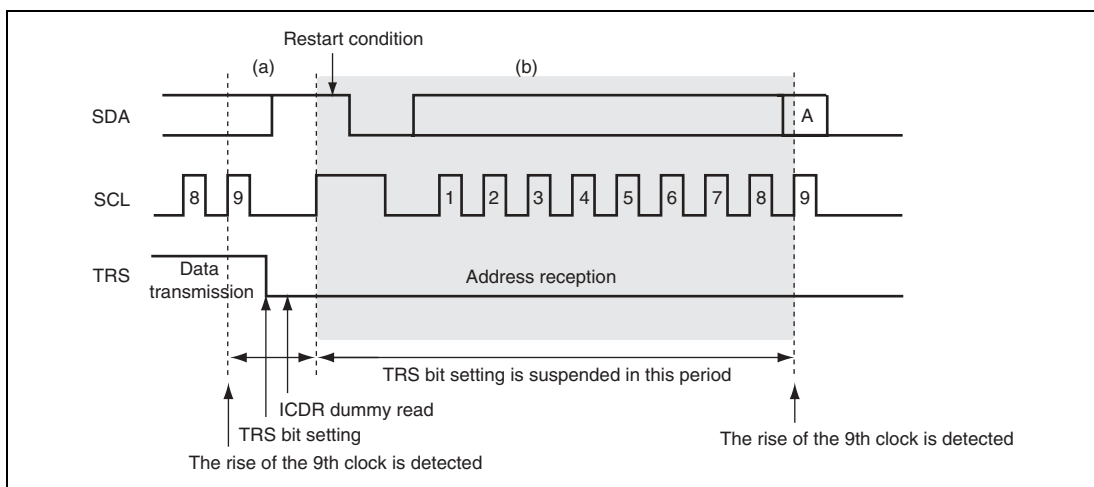

Figure 13.34 TRS Bit Set Timing in Slave Mode

Note: This restriction on usage can be canceled by setting the FNC1 and FNC0 bits to 1 in ICCR.

13. Note on ICDR read in transmit mode and ICDR write in receive mode

If ICDR is read in transmit mode (TRS = 1) or ICDR is written to in receive mode (TRS = 0), the SCL pin may not be held low in some cases after transmit/receive operation has been completed, thus inconveniently allowing clock pulses to be output on the SCL bus line before ICDR is accessed correctly. To access ICDR correctly, read ICDR after setting receive mode or write to ICDR after setting transmit mode.

14. Note on ACKE and TRS bits in slave mode

In the I²C bus interface, if 1 is received as the acknowledge bit value (ACKB = 1) in transmit mode (TRS = 1) and then the address is received in slave mode without performing appropriate processing, interrupt handling may start at the rising edge of the 9th clock pulse even when the address does not match. Similarly, if the start condition or address is transmitted from the master device in slave transmit mode (TRS = 1), the IRIC flag may be set after the ICDRE flag is set and 1 received as the acknowledge bit value (ACKB = 1), thus causing an interrupt source even when the address does not match.

To use the I²C bus interface module in slave mode, be sure to follow the procedures below.

- A. When having received 1 as the acknowledge bit value for the last transmit data at the end of a series of transmit operation, clear the ACKE bit in ICCR once to initialize the ACKB bit to 0.
- B. Set receive mode (TRS = 0) before the next start condition is input in slave mode.
Complete transmit operation by the procedure shown in figure 13.23, in order to switch from slave transmit mode to slave receive mode.

15. Note on Arbitration Lost in Master Mode

The I²C bus interface recognizes the data in transmit/receive frame as an address when arbitration is lost in master mode and a transition to slave receive mode is automatically carried out.

When arbitration is lost not in the first frame but in the second frame or subsequent frame, transmit/receive data that is not an address is compared with the value set in the SAR or SARX register as an address. If the receive data matches with the address in the SAR or SARX register, the I²C bus interface erroneously recognizes that the address call has occurred. (See figure 13.35.)

In multi-master mode, a bus conflict could happen. When the I²C bus interface is operated in master mode, check the state of the AL bit in the ICSR register every time after one frame of data has been transmitted or received.

When arbitration is lost during transmitting the second frame or subsequent frame, take avoidance measures.

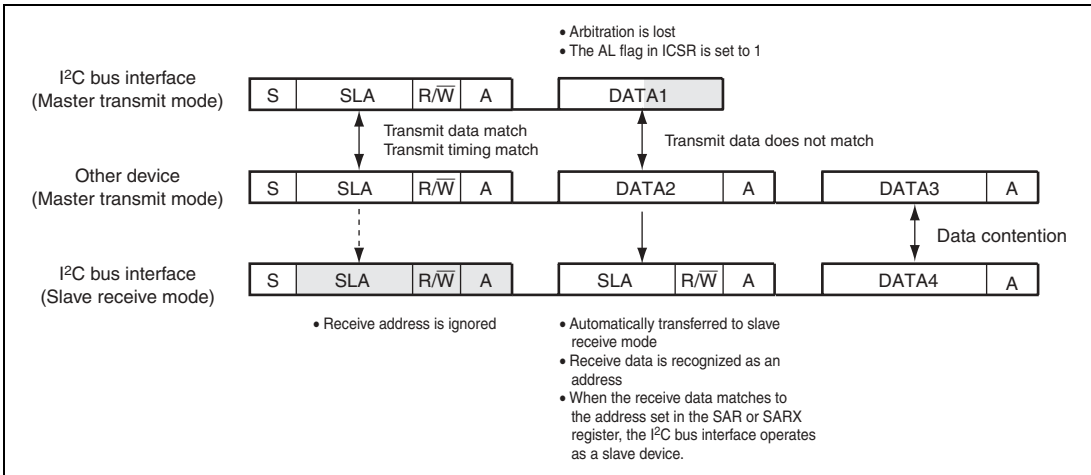

Figure 13.35 Diagram of Erroneous Operation when Arbitration is Lost

Though it is prohibited in the normal I²C protocol, the same problem may occur when the MST bit is erroneously set to 1 and a transition to master mode is occurred during data transmission or reception in slave mode. In multi-master mode, pay attention to the setting of the MST bit when a bus conflict may occur. In this case, the MST bit in the ICCR register should be set to 1 according to the order below.

- A. Make sure that the BBSY flag in the ICCR register is 0 and the bus is free before setting the MST bit.
- B. Set the MST bit to 1.
- C. To confirm that the bus was not entered to the busy state while the MST bit is being set, check that the BBSY flag in the ICCR register is 0 immediately after the MST bit has been set.

Note: Above restriction can be cleared by setting bits FNC1 and FNC0 in the ICXR register.

13.6.1 Module Stop Mode Setting

The IIC operation can be enabled or disabled using the module stop control register. The initial setting is for the IIC operation to be halted. Register access is enabled by canceling module stop mode. For details, see section 20, Power-Down Modes.

Section 14 Keyboard Buffer Controller

This LSI has three on-chip keyboard buffer controller channels. The keyboard buffer controller is provided with functions conforming to the PS/2 interface specifications.

Data transfer using the keyboard buffer controller employs a data line (KD) and a clock line (KCLK), providing economical use of connectors, board surface area, etc. Figure 14.1 shows a block diagram of the keyboard buffer controller.

14.1 Features

- Conforms to PS/2 interface specifications
- Direct bus drive (via the KCLK and KD pins)
- Interrupt sources: on completion of data reception and on detection of clock edge
- Error detection: parity error and stop bit monitoring

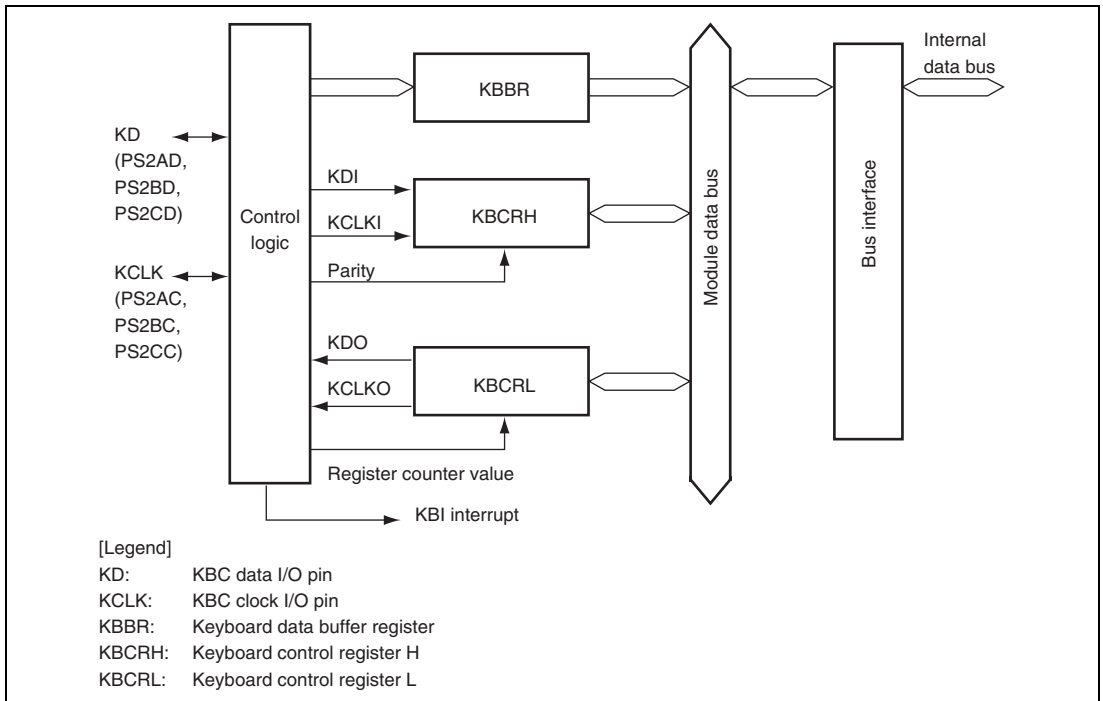

Figure 14.1 Block Diagram of Keyboard Buffer Controller

Figure 14.2 shows how the keyboard buffer controller is connected.

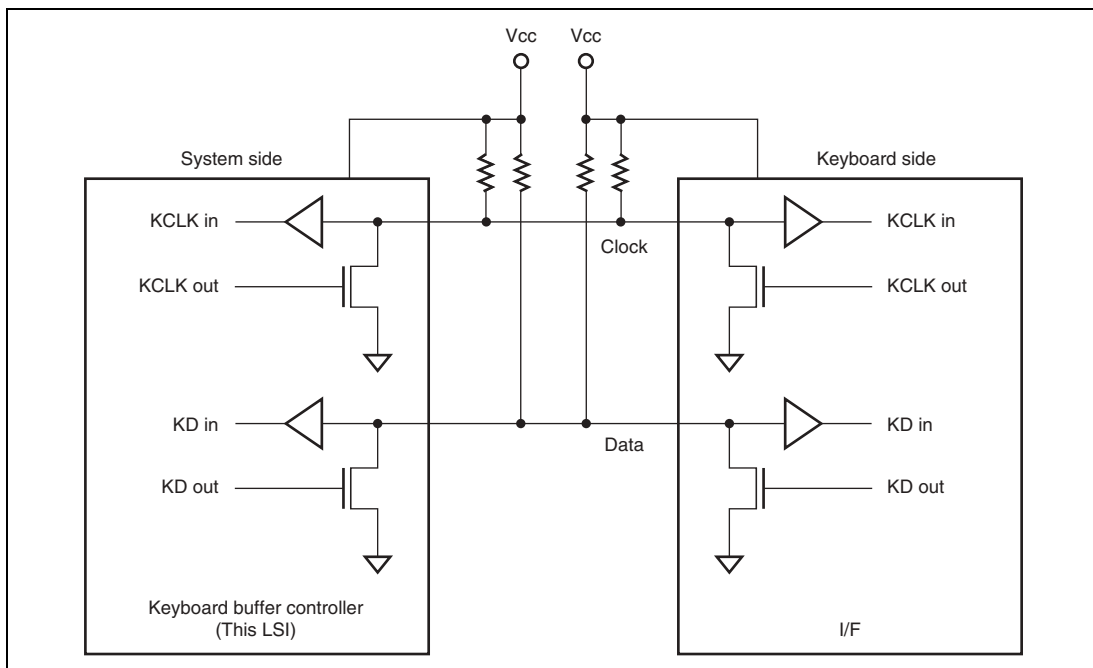

Figure 14.2 Keyboard Buffer Controller Connection

14.2 Input/Output Pins

Table 14.1 lists the input/output pins used by the keyboard buffer controller.

Table 14.1 Pin Configuration

Channel	Name	Abbreviation*	I/O	Function
0	KBC clock I/O pin (KCLK0)	PS2AC	I/O	KBC clock input/output
	KBC data I/O pin (KD0)	PS2AD	I/O	KBC data input/output
1	KBC clock I/O pin (KCLK1)	PS2BC	I/O	KBC clock input/output
	KBC data I/O pin (KD1)	PS2BD	I/O	KBC data input/output
2	KBC clock I/O pin (KCLK2)	PS2CC	I/O	KBC clock input/output
	KBC data I/O pin (KD2)	PS2CD	I/O	KBC data input/output

Note: * These are the external I/O pin names. In the text, clock I/O pins are referred to as KCLK and data I/O pins as KD, omitting the channel designations.

14.3 Register Descriptions

The keyboard buffer controller has the following registers for each channel.

- Keyboard control register H (KBCRH)
- Keyboard control register L (KBCRL)
- Keyboard data buffer register (KBBR)

14.3.1 Keyboard Control Register H (KBCRH)

KBCRH indicates the operating status of the keyboard buffer controller.

Bit	Bit Name	Initial Value	R/W	Description
7	KBIOE	0	R/W	Keyboard In/Out Enable Selects whether or not the keyboard buffer controller is used. 0: The keyboard buffer controller is non-operational (KCLK and KD signal pins have port functions) 1: The keyboard buffer controller is enabled for transmission and reception (KCLK and KD signal pins are in the bus drive state)
6	KCLKI	1	R/W	Keyboard Clock In Monitors the KCLK I/O pin. This bit cannot be modified. 0: KCLK I/O pin is low 1: KCLK I/O pin is high
5	KDI	1	R/W	Keyboard Data In: Monitors the KDI I/O pin. This bit cannot be modified. 0: KD I/O pin is low 1: KD I/O pin is high
4	KBFSEL	1	R/W	Keyboard Buffer Register Full Select Selects whether the KBF bit is used as the keyboard buffer register full flag or as the KCLK fall interrupt flag. When KBFSEL is cleared to 0, the KBE bit in KBCRL should be cleared to 0 to disable reception. 0: KBF bit is used as KCLK fall interrupt flag 1: KBF bit is used as keyboard buffer register full flag

Bit	Bit Name	Initial Value	R/W	Description
3	KBIE	0	R/W	<p>Keyboard Interrupt Enable</p> <p>Enables or disables interrupts from the keyboard buffer controller to the CPU.</p> <p>0: Interrupt requests are disabled</p> <p>1: Interrupt requests are enabled</p>
2	KBF	0	R/(W)*	<p>Keyboard Buffer Register Full</p> <p>Indicates that data reception has been completed and the received data is in KBBR.</p> <p>0: [Clearing condition]</p> <p>Read KBF when KBF = 1, then write 0 in KBF</p> <p>1: [Setting conditions]</p> <ul style="list-style-type: none"> When data has been received normally and has been transferred to KBBR while KBFSEL = 1 (keyboard buffer register full flag) When a KCLK falling edge is detected while KBFSEL = 0 (KCLK interrupt flag)
1	PER	0	R/(W)*	<p>Parity Error</p> <p>Indicates that an odd parity error has occurred.</p> <p>0: [Clearing condition]</p> <p>Read PER when PER = 1, then write 0 in PER</p> <p>1: [Setting condition]</p> <p>When an odd parity error occurs</p>
0	KBS	0	R	<p>Keyboard Stop</p> <p>Indicates the receive data stop bit. Valid only when KBF = 1.</p> <p>0: 0 stop bit received</p> <p>1: 1 stop bit received</p>

Note: * Only 0 can be written for clearing the flag.

14.3.2 Keyboard Control Register L (KBCRL)

KBCRL enables the receive counter count and controls the keyboard buffer controller pin output.

Bit	Bit Name	Initial Value	R/W	Description
7	KBE	0	R/W	Keyboard Enable Enables or disables loading of receive data into KBBR. 0: Loading of receive data into KBBR is disabled 1: Loading of receive data into KBBR is enabled
6	KCLKO	1	R/W	Keyboard Clock Out Controls KBC clock I/O pin output. 0: KBC clock I/O pin is low 1: KBC clock I/O pin is high
5	KDO	1	R/W	Keyboard Data Out Controls KBC data I/O pin output. 0: KBC data I/O pin is low 1: KBC data I/O pin is high
4	—	1	—	Reserved This bit is always read as 1 and cannot be modified.
3	RXCR3	0	R	Receive Counter
2	RXCR2	0	R	These bits indicate the received data bit. Their value is incremented on the fall of KCLK. These bits cannot be modified. The receive counter is initialized to 0000 by a reset and when 0 is written in KBE. Its value returns to 0000 after a stop bit is received. 0000: — 0001: Start bit 0010: KB0 0011: KB1 0100: KB2 0101: KB3 0110: KB4 0111: KB5 1000: KB6 1001: KB7 1010: Parity bit 1011: — 11- - : —
1	RXCR1	0	R	
0	RXCR0	0	R	

14.3.3 Keyboard Data Buffer Register (KBBR)

KBBR stores receive data. Its value is valid only when KBF = 1.

Bit	Bit Name	Initial Value	R/W	Description
7	KB7	0	R	Keyboard Data 7 to 0
6	KB6	0	R	8-bit read only data.
5	KB5	0	R	Initialized to H'00 by a reset, in standby mode, watch mode, subactive mode, subsleep mode, and module stop mode, and when KBIOE is cleared to 0.
4	KB4	0	R	
3	KB3	0	R	
2	KB2	0	R	
1	KB1	0	R	
0	KB0	0	R	

14.4 Operation

14.4.1 Receive Operation

In a receive operation, both KCLK (clock) and KD (data) are outputs on the keyboard side and inputs on this LSI chip (system) side. KD receives a start bit, 8 data bits (LSB-first), an odd parity bit, and a stop bit, in that order. The KD value is valid when KCLK is low. A sample receive processing flowchart is shown in figure 14.3, and the receive timing in figure 14.4.

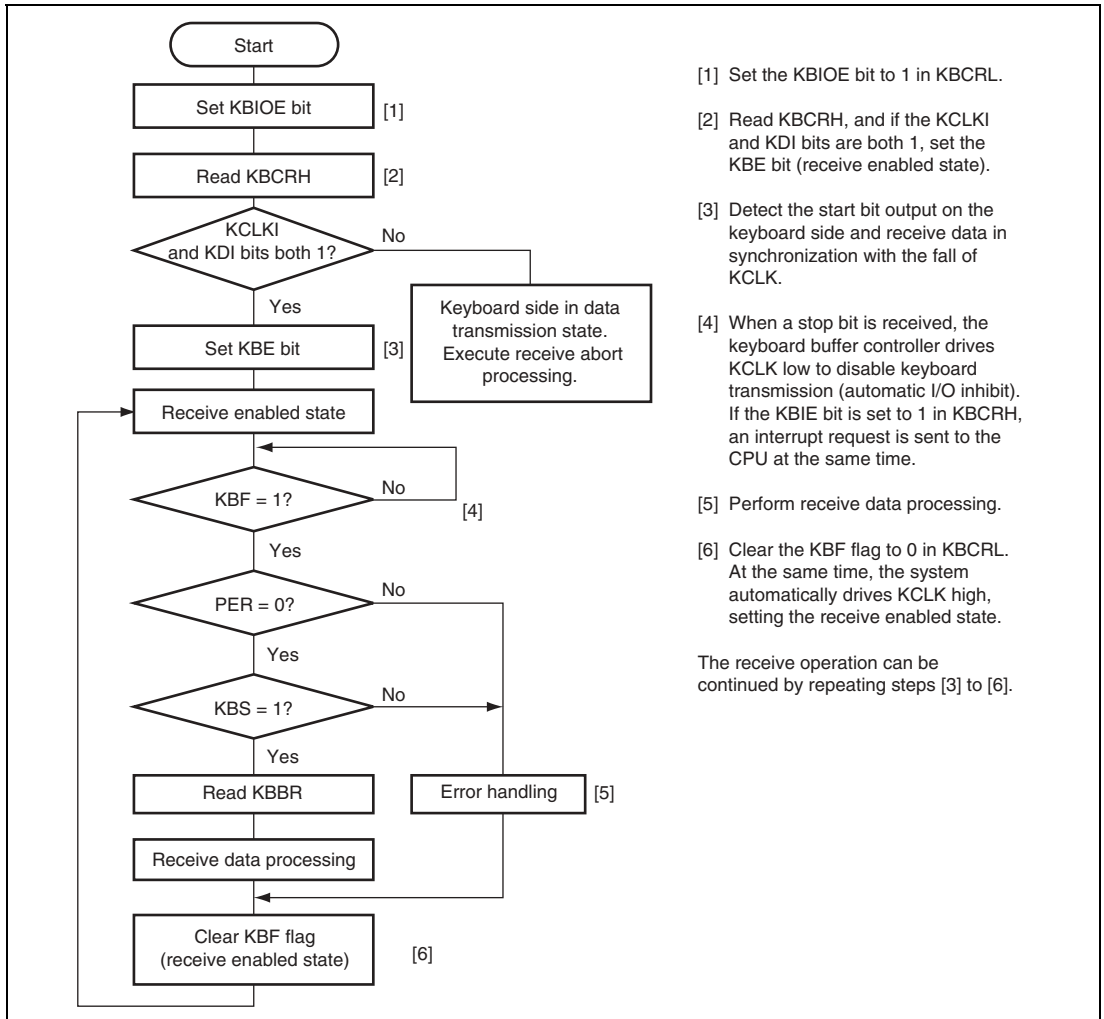

Figure 14.3 Sample Receive Processing Flowchart

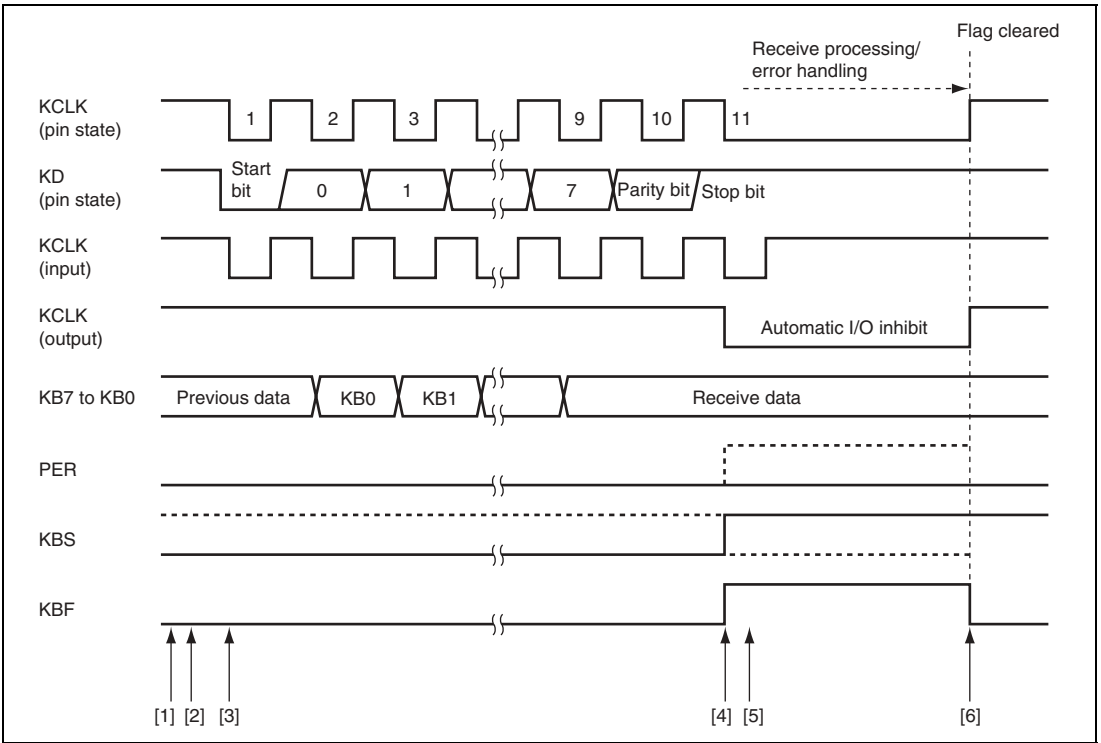

Figure 14.4 Receive Timing

14.4.2 Transmit Operation

In a transmit operation, KCLK (clock) is an output on the keyboard side, and KD (data) is an output on the chip (system) side. KD outputs a start bit, 8 data bits (LSB-first), an odd parity bit, and a stop bit, in that order. The KD value is valid when KCLK is high. A sample transmit processing flowchart is shown in figure 14.5, and the transmit timing in figure 14.6.

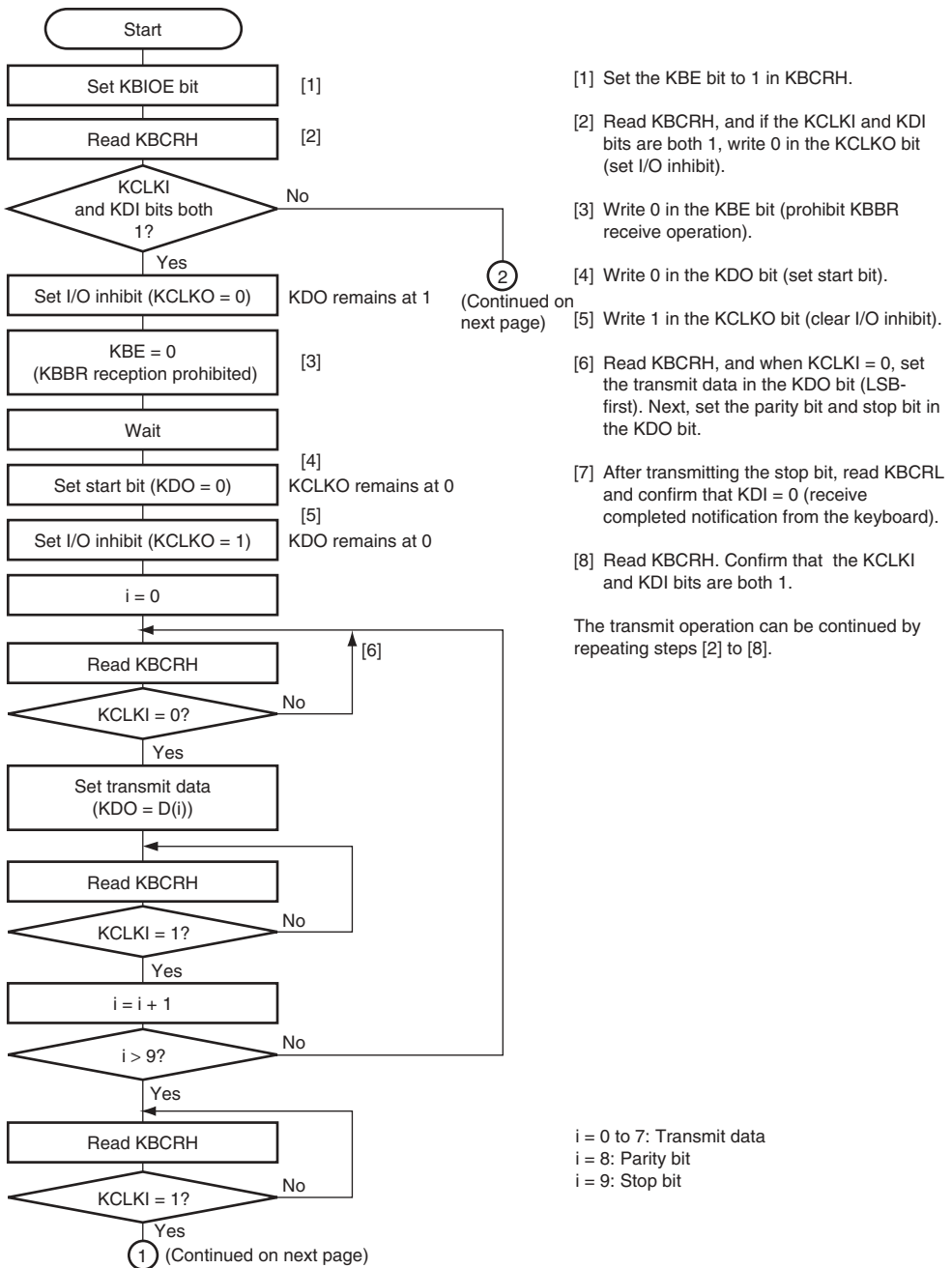

Figure 14.5 Sample Transmit Processing Flowchart (1)

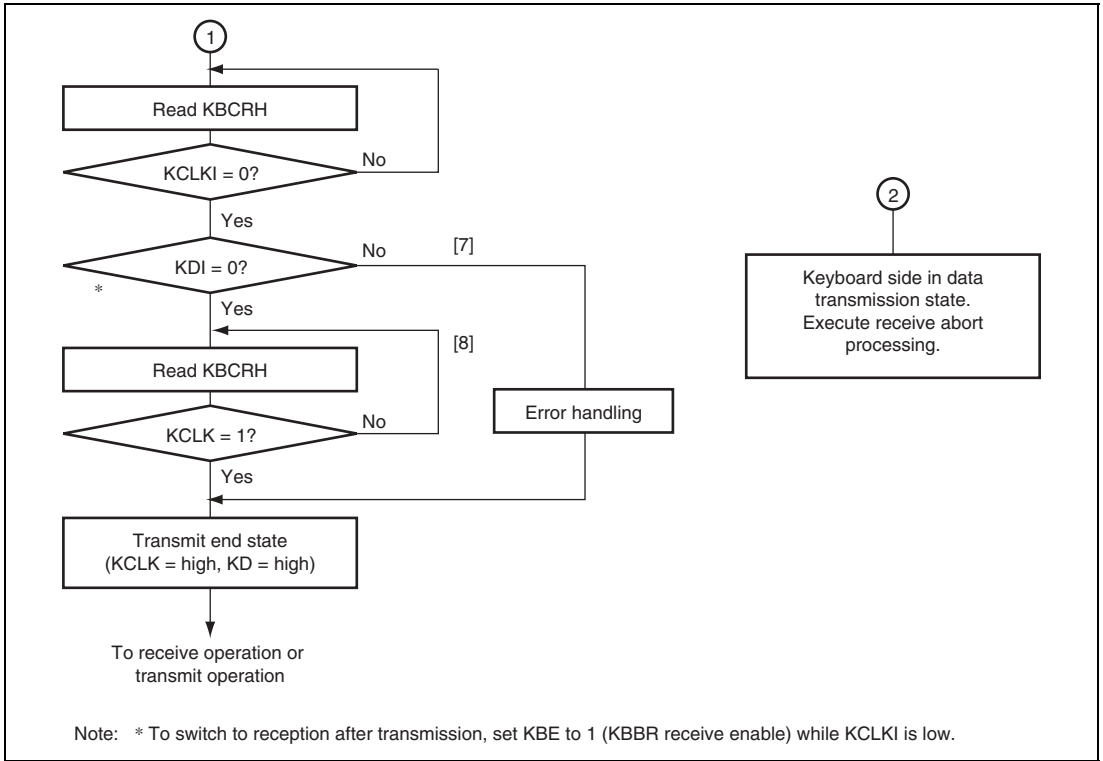

Figure 14.5 Sample Transmit Processing Flowchart (2)

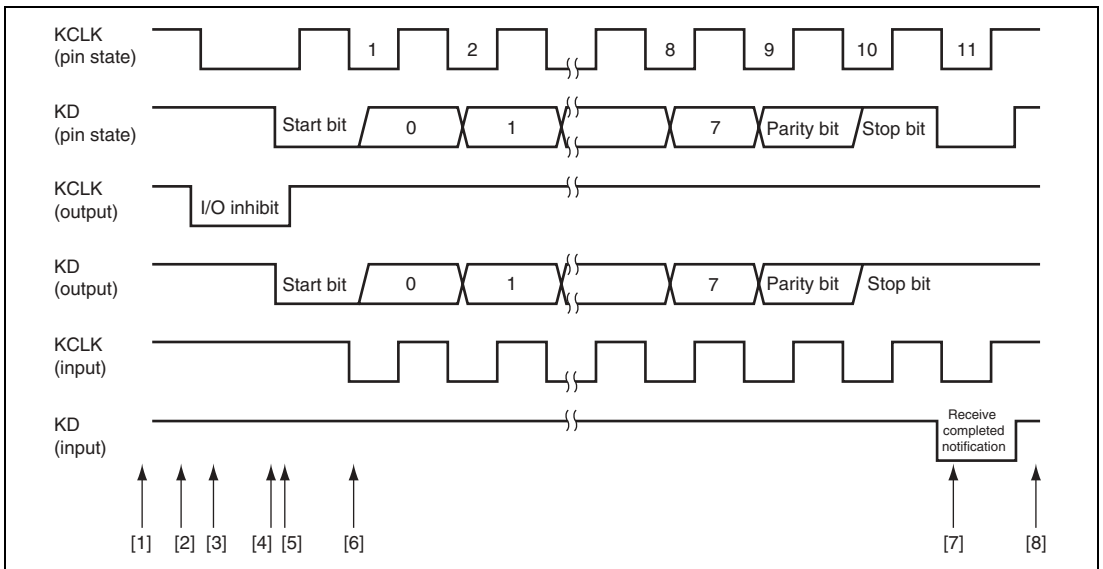

Figure 14.6 Transmit Timing

14.4.3 Receive Abort

This LSI (system side) can forcibly abort transmission from the device connected to it (keyboard side) in the event of a protocol error, etc. In this case, the system holds the clock low. During reception, the keyboard also outputs a clock for synchronization, and the clock is monitored when the keyboard output clock is high. If the clock is low at this time, the keyboard judges that there is an abort request from the system, and data transmission from the keyboard is aborted. Thus the system can abort reception by holding the clock low for a certain period. A sample receive abort processing flowchart is shown in figure 14.7, and the receive abort timing in figure 14.8.

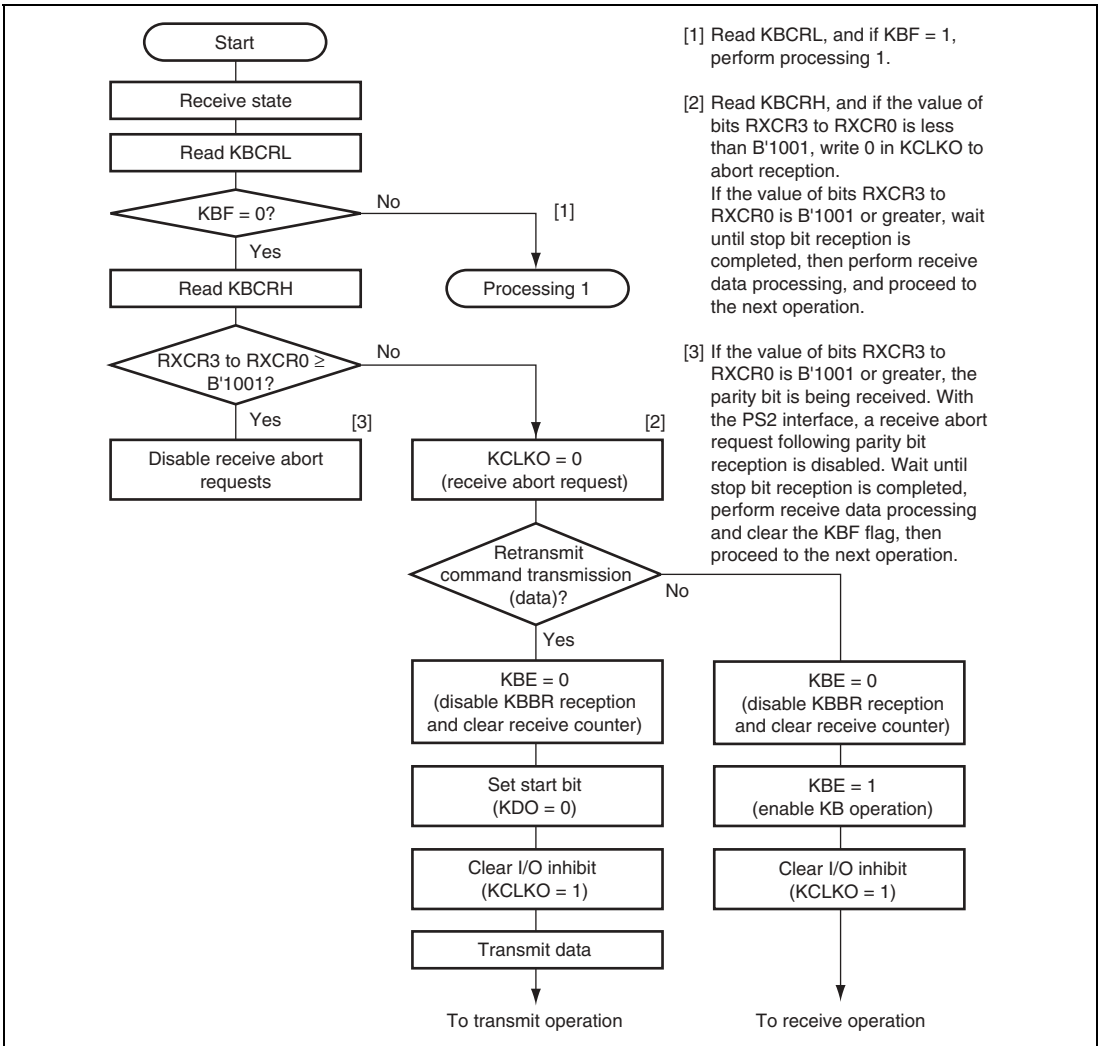

Figure 14.7 Sample Receive Abort Processing Flowchart (1)

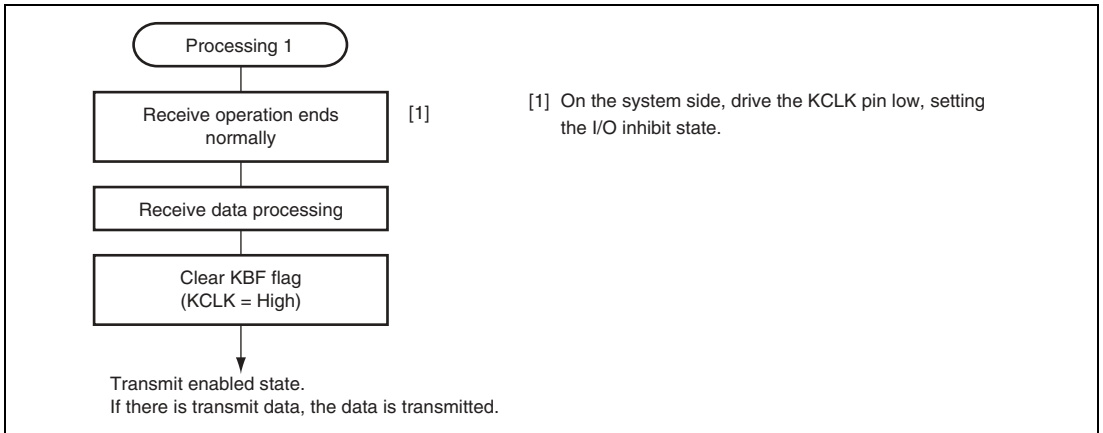

Figure 14.7 Sample Receive Abort Processing Flowchart (2)

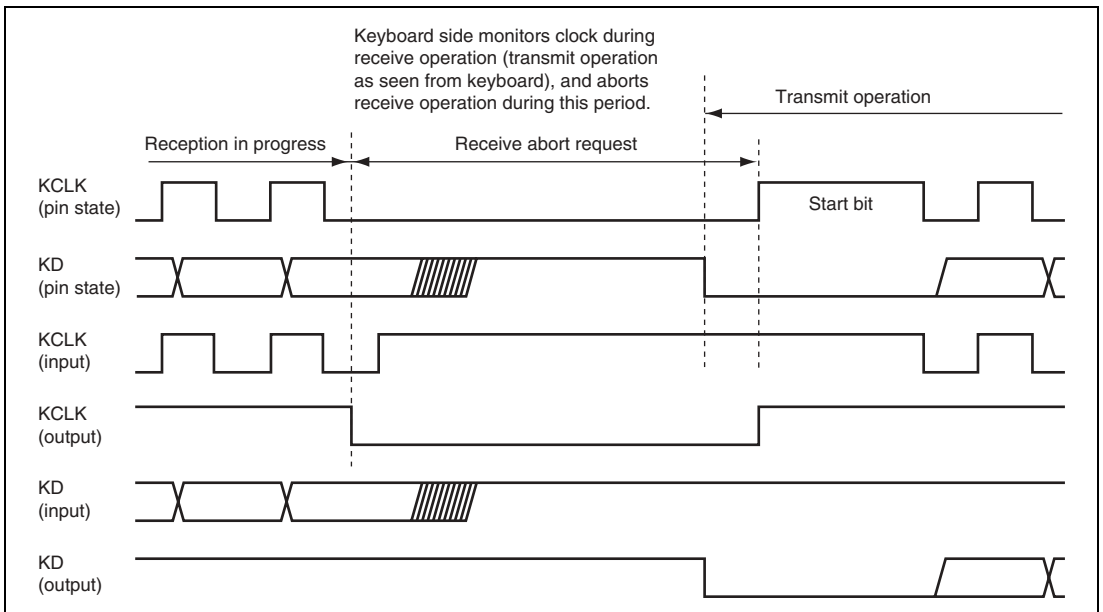

Figure 14.8 Receive Abort and Transmit Start (Transmission/Reception Switchover) Timing

14.4.4 KCLKI and KDI Read Timing

Figure 14.9 shows the KCLKI and KDI read timing.

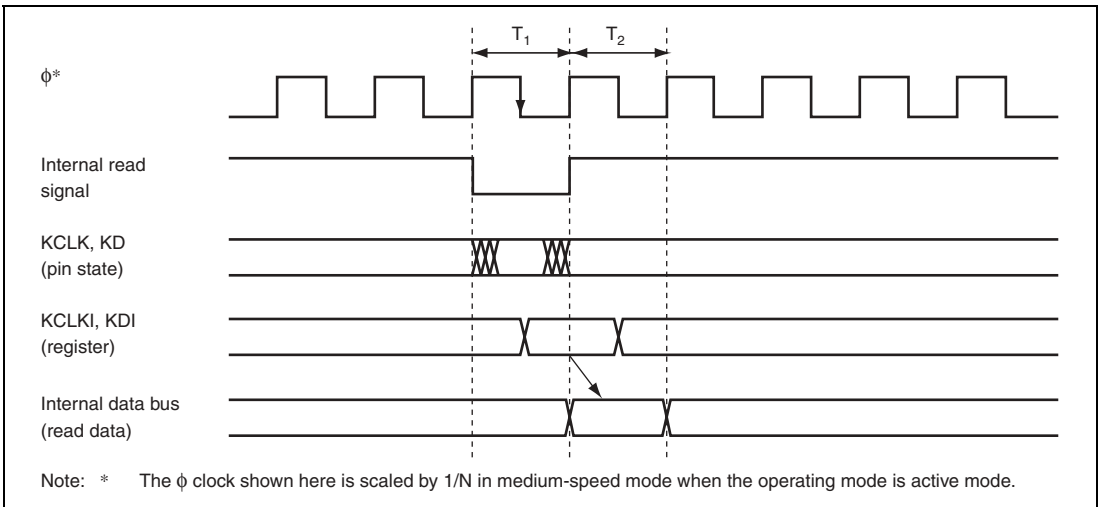

Figure 14.9 KCLKI and KDI Read Timing

14.4.5 KCLKO and KDO Write Timing

Figure 14.10 shows the KCLKO and KDO write timing and the KCLK and KD pin states.

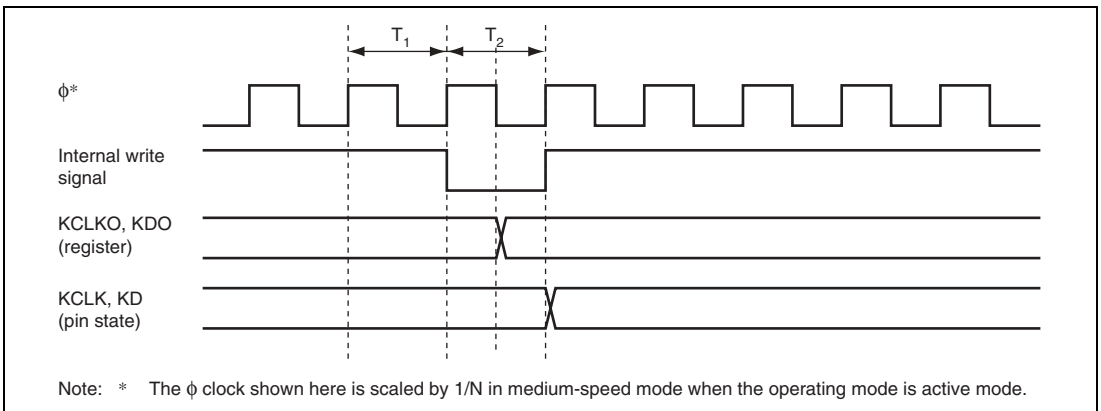

Figure 14.10 KCLKO and KDO Write Timing

14.4.6 KBF Setting Timing and KCLK Control

Figure 14.11 shows the KBF setting timing and the KCLK pin states.

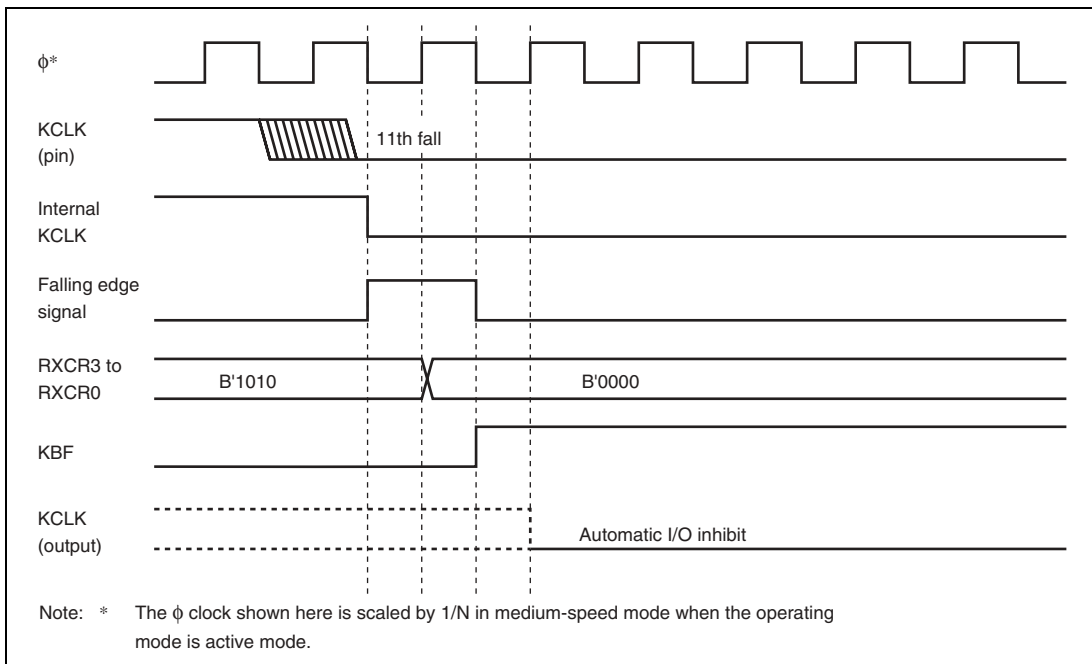

Figure 14.11 KBF Setting and KCLK Automatic I/O Inhibit Generation Timing

14.4.7 Receive Timing

Figure 14.12 shows the receive timing.

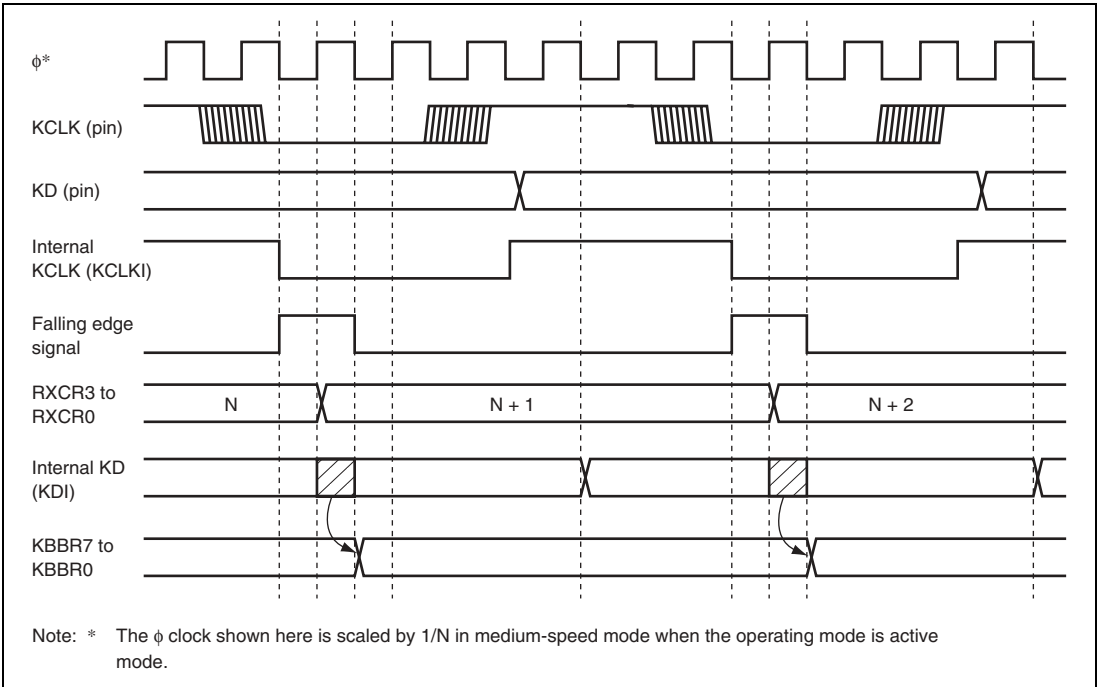

Figure 14.12 Receive Counter and KBBR Data Load Timing

14.4.8 KCLK Fall Interrupt Operation

In this device, clearing the KBFSEL bit to 0 in KBCRH enables the KBF bit in KBCRL to be used as a flag for the interrupt generated by the fall of KCLK input.

Figure 14.13 shows the setting method and an example of operation.

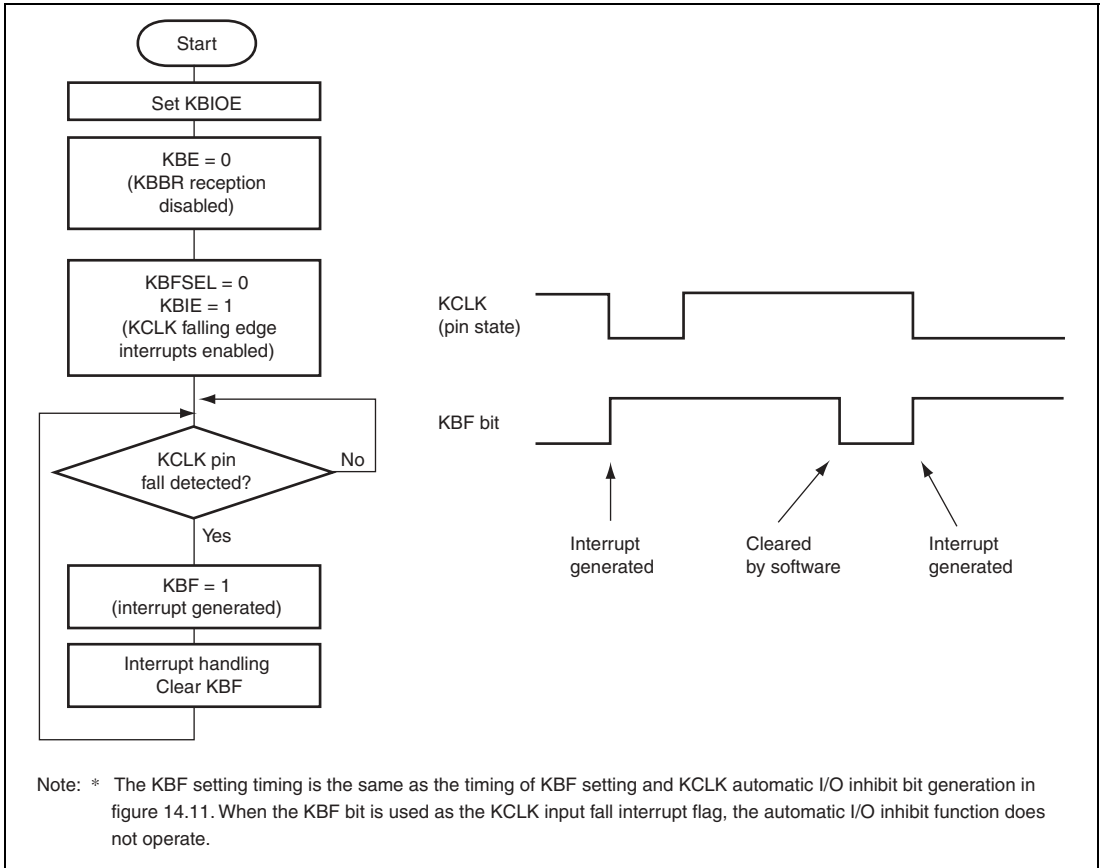

Figure 14.13 Example of KCLK Input Fall Interrupt Operation

14.5 Usage Notes

14.5.1 KBIOE Setting and KCLK Falling Edge Detection

When KBIOE is 0, the internal KCLK and internal KD settings are fixed at 1. Therefore, if the KCLK pin is low when the KBIOE bit is set to 1, the edge detection circuit operates and the KCLK falling edge is detected.

If the KBFSEL bit and KBE bit are both 0 at this time, the KBF bit is set. Figure 14.14 shows the timing of KBIOE setting and KCLK falling edge detection.

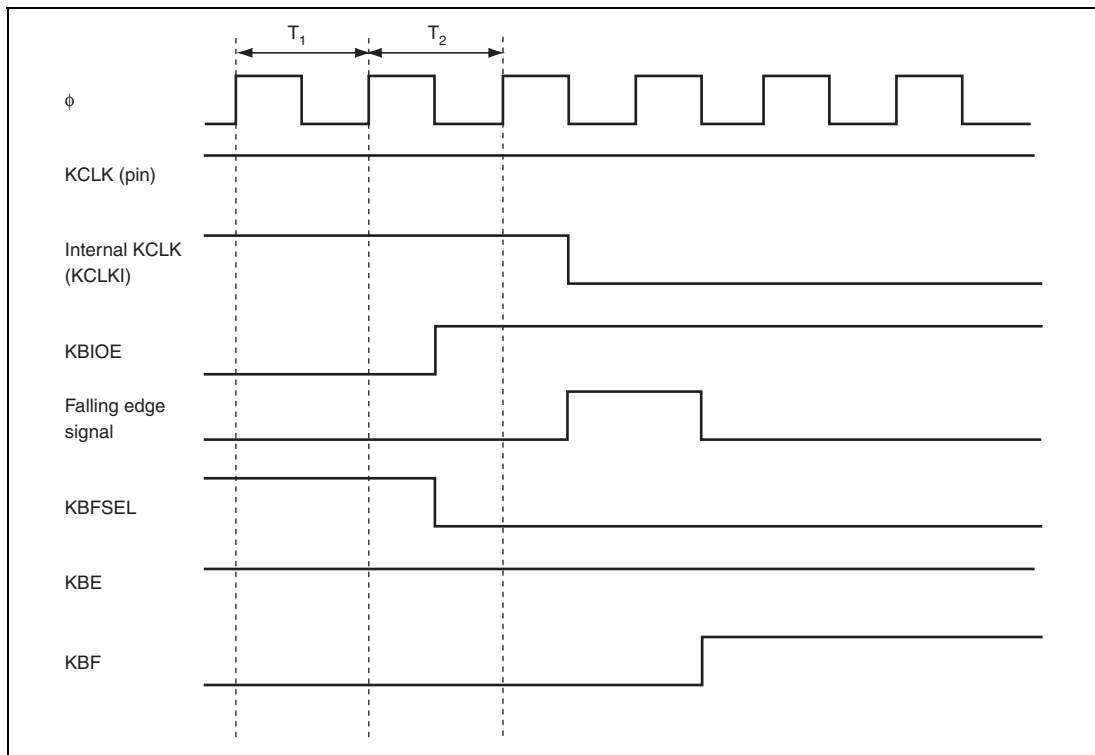

Figure 14.14 KBIOE Setting and KCLK Falling Edge Detection Timing

14.5.2 Module Stop Mode Setting

Keyboard buffer controller operation can be enabled or disabled using the module stop control register. The initial setting is for keyboard buffer controller operation to be halted. Register access is enabled by canceling module stop mode. For details, refer to section 20, Power-Down Modes.

Section 15 Host Interface (LPC)

This LSI has an on-chip LPC interface.

The LPC performs serial transfer of cycle type, address, and data, synchronized with the 33 MHz PCI clock. It uses four signal lines for address/data, and one for host interrupt requests. This LPC module supports only I/O read cycle and I/O write cycle transfers.

It is also provided with power-down functions that can control the PCI clock and shut down the host interface.

15.1 Features

- Supports LPC interface I/O read cycles and I/O write cycles
 - Uses four signal lines (LAD3 to LAD0) to transfer the cycle type, address, and data.
 - Uses three control signals: clock (LCLK), reset ($\overline{\text{LRESET}}$), and frame ($\overline{\text{LFRAME}}$).
- Has three register sets comprising data and status registers
 - The basic register set comprises three bytes: an input register (IDR), output register (ODR), and status register (STR).
 - Channels 1 and 2 have fixed I/O addresses of H'60/H'64 and H'62/H'66, respectively. A fast A20 gate function is also provided.
 - The I/O address can be set for channel 3. Sixteen bidirectional data register bytes can be manipulated in addition to the basic register set.
- Supports SERIRQ
 - Host interrupt requests are transferred serially on a single signal line (SERIRQ).
 - On channel 1, HIRQ1 and HIRQ12 can be generated.
 - On channels 2 and 3, SMI, HIRQ6, and HIRQ9 to HIRQ11 can be generated.
 - Operation can be switched between quiet mode and continuous mode.
 - The $\overline{\text{CLKRUN}}$ signal can be manipulated to restart the PCI clock (LCLK).
- Eleven interrupt sources
 - The LPC module can be shut down by inputting the $\overline{\text{LPCPD}}$ signal.
 - Three pins, $\overline{\text{PME}}$, $\overline{\text{LSMI}}$, and LSCI, are provided for general input/output.

Figure 15.1 shows a block diagram of the LPC.

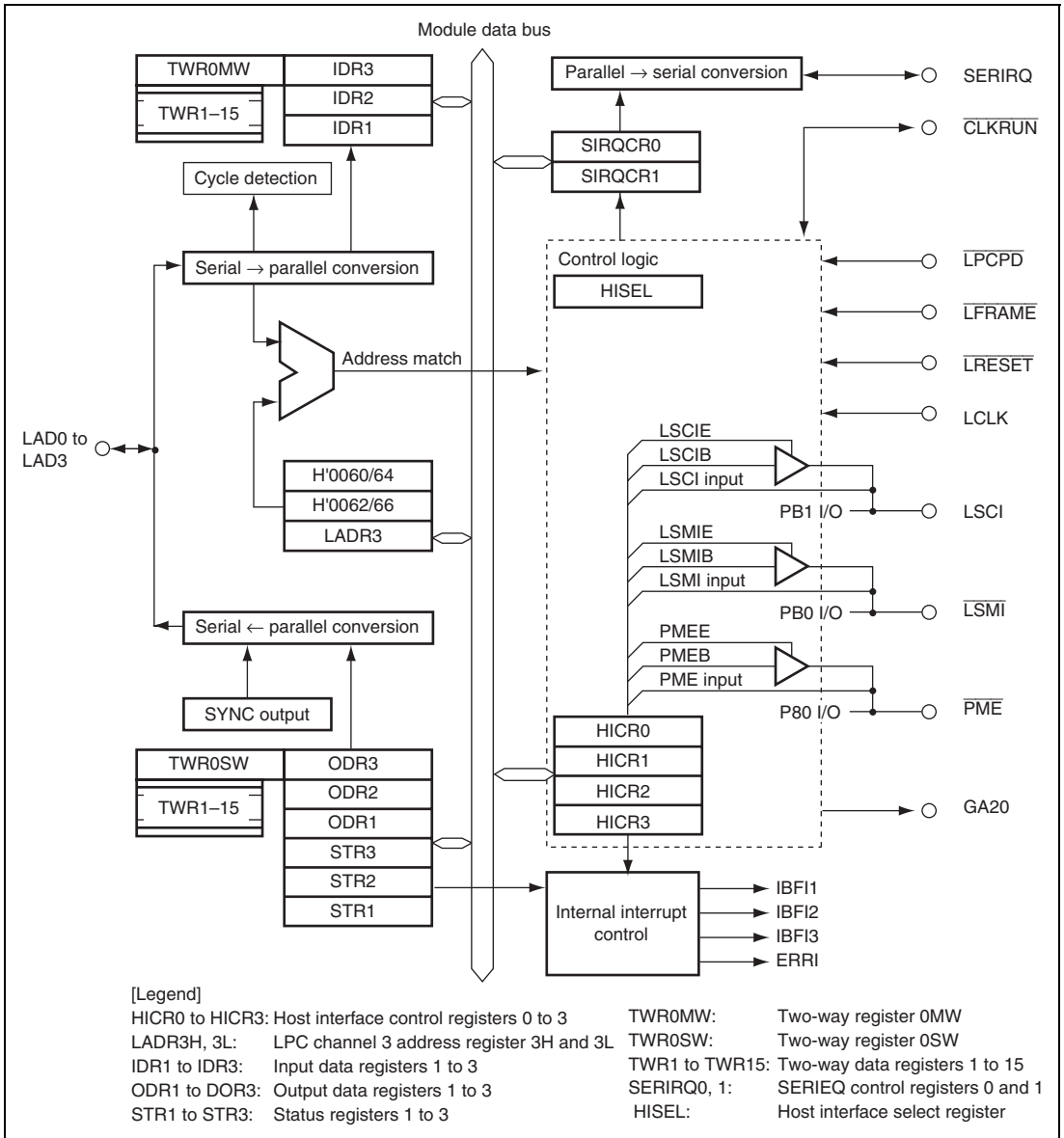

Figure 15.1 Block Diagram of LPC

15.2 Input/Output Pins

Table 15.1 lists the input and output pins of the LPC module.

Table 15.1 Pin Configuration

Name	Abbreviation	Port	I/O	Function
LPC address/ data 3 to 0	LAD3 to LAD0	P33 to P30	Input/ output	Serial (4-signal-line) transfer cycle type/address/data signals, synchronized with LCLK
LPC frame	$\overline{\text{LFRAME}}$	P34	Input* ¹	Transfer cycle start and forced termination signal
LPC reset	$\overline{\text{LRESET}}$	P35	Input* ¹	LPC interface reset signal
LPC clock	LCLK	P36	Input	33 MHz PCI clock signal
Serialized interrupt request	SERIRQ	P37	Input/ output* ¹	Serialized host interrupt request signal, synchronized with LCLK (SMI, IRQ1, IRQ6, IRQ9 to IRQ12)
LSCI general output	LSCI	PB1	Output* ^{1, *2}	General output
LSMI general output	$\overline{\text{LSMI}}$	PB0	Output* ^{1, *2}	General output
PME general output	$\overline{\text{PME}}$	P80	Output* ^{1, *2}	General output
GATE A20	GA20	P81	Output* ^{1, *2}	A20 gate control signal output
LPC clock run	$\overline{\text{CLKRUN}}$	P82	Input/ output* ^{1, *2}	LCLK restart request signal in case of serial host interrupt request
LPC power-down	$\overline{\text{LPCPD}}$	P83	Input* ¹	LPC module shutdown signal

Notes: 1. Pin state monitoring input is possible in addition to the LPC interface control input/output function.

2. Only 0 can be output. If 1 is output, the pin goes to the high-impedance state, so an external resistor is necessary to pull the signal up to V_{CC} .

15.3 Register Descriptions

The LPC has the following registers.

- Host interface control register 0 (HICR0)
- Host interface control register 1 (HICR1)
- Host interface control register 2 (HICR2)
- Host interface control register 3 (HICR3)
- LPC channel 3 address registers (LADR3H, LADR3L)
- Input data register 1 (IDR1)
- Output data register 1 (ODR1)
- Status register 1 (STR1)
- Input data register 2 (IDR2)
- Output data register 2 (ODR2)
- Status register 2 (STR2)
- Input data register 3 (IDR3)
- Output data register 3 (ODR3)
- Status register 3 (STR3)
- Bidirectional data registers 0 to 15 (TWR0 to TWR15)
- SERIRQ control register 0 (SIRQCR0)
- SERIRQ control register 1 (SIRQCR1)
- Host interface select register (HISEL)

15.3.1 Host Interface Control Registers 0 and 1 (HICR0, HICR1)

HICR0 and HICR1 contain control bits that enable or disable host interface functions, control bits that determine pin output and the internal state of the host interface, and status flags that monitor the internal state of the host interface.

- HICR0

Bit	Bit Name	Initial Value	R/W		Description
			Slave	Host	
7	LPC3E	0	R/W	—	LPC Enable 3 to 1
6	LPC2E	0	R/W	—	Enable or disable the host interface function in single-chip mode. When the host interface is enabled (one of the three bits is set to 1), processing for data transfer between the slave processor (this LSI) and the host processor is performed using pins LAD3 to LAD0, $\overline{\text{LFRAME}}$, $\overline{\text{LRESET}}$, LCLK, SERIRQ, $\overline{\text{CLKRUN}}$, and $\overline{\text{LPCPD}}$.
5	LPC1E	0	R/W	—	<ul style="list-style-type: none"> • LPC3E <ul style="list-style-type: none"> 0: LPC channel 3 operation is disabled No address (LADR3) matches for IDR3, ODR3, STR3, or TWR0 to TWR15 1: LPC channel 3 operation is enabled • LPC2E <ul style="list-style-type: none"> 0: LPC channel 2 operation is disabled No address (H'0062, 66) matches for IDR2, ODR2, or STR2 1: LPC channel 2 operation is enabled • LPC1E <ul style="list-style-type: none"> 0: LPC channel 1 operation is disabled No address (H'0060, 64) matches for IDR1, ODR1, or STR1 1: LPC channel 1 operation is enabled

Bit	Bit Name	Initial Value	R/W		Description
			Slave	Host	
4	FGA20E	0	R/W	—	<p>Fast A20 Gate Function Enable</p> <p>Enables or disables the fast A20 gate function. When the fast A20 gate is disabled, the normal A20 gate can be implemented by firmware operation of the P81 output.</p> <p>When the fast A20 gate function is enabled, the DDR bit for P81 must not be set to 1.</p> <p>0: Fast A20 gate function disabled</p> <ul style="list-style-type: none"> • Other function of pin P81 is enabled • GA20 output internal state is initialized to 1 <p>1: Fast A20 gate function enabled</p> <ul style="list-style-type: none"> • GA20 pin output is open-drain (external VCC pull-up resistor required)
3	SDWNE	0	R/W	—	<p>LPC Software Shutdown Enable</p> <p>Controls host interface shutdown. For details of the LPC shutdown function, and the scope of initialization by an LPC reset and an LPC shutdown, see section 15.4.4, Host Interface Shutdown Function (LPCPD).</p> <p>0: Normal state, LPC software shutdown setting enabled [Clearing conditions]</p> <ul style="list-style-type: none"> • Writing 0 • LPC hardware reset or LPC software reset • LPC hardware shutdown release (rising edge of $\overline{\text{LPCPD}}$ signal) <p>1: LPC hardware shutdown state setting enabled</p> <ul style="list-style-type: none"> • Hardware shutdown state when $\overline{\text{LPCPD}}$ signal is low [Setting condition] • Writing 1 after reading SDWNE = 0

Bit	Bit Name	Initial Value	R/W		Description
			Slave	Host	
2	PMEE	0	R/W	—	<p>PME output Enable</p> <p>Controls PME output in combination with the PMEB bit in HICR1. PME pin output is open-drain, and an external pull-up resistor is needed to pull the output up to V_{cc}. When the PME output function is used, the DDR bit for P80 must not be set to 1.</p> <p>PMEE PMEB</p> <p>0 x: PME output disabled, other function of pin is enabled</p> <p>1 0: PME output enabled, $\overline{\text{PME}}$ pin output goes to 0 level</p> <p>1 1: PME output enabled, $\overline{\text{PME}}$ pin output is high-impedance</p>
1	LSMIE	0	R/W	—	<p>LSMI output Enable</p> <p>Controls LSMI output in combination with the LSMIB bit in HICR1. $\overline{\text{LSMI}}$ pin output is open-drain, and an external pull-up resistor is needed to pull the output up to V_{cc}. When the LSMI output function is used, the DDR bit for PB0 must not be set to 1.</p> <p>LSMIE LSMIB</p> <p>0 x: LSMI output disabled, other function of pin is enabled</p> <p>1 0: LSMI output enabled, $\overline{\text{LSMI}}$ pin output goes to 0 level</p> <p>1 1: LSMI output enabled, $\overline{\text{LSMI}}$ pin output is high-impedance</p>
0	LSCIE	0	R/W	—	<p>LSCI output Enable</p> <p>Controls LSCI output in combination with the LSCIB bit in HICR1. LSCI pin output is open-drain, and an external pull-up resistor is needed to pull the output up to V_{cc}. When the LSCI output function is used, the DDR bit for PB1 must not be set to 1.</p> <p>LSCIE LSCIB</p> <p>0 x: LSCI output disabled, other function of pin is enabled</p> <p>1 0: LSCI output enabled, LSCI pin output goes to 0 level</p> <p>1 1: LSCI output enabled, LSCI pin output is high-impedance</p>

[Legend]

X: Don't care

- HICR1

Bit	Bit Name	Initial		R/W	Description
		Value	Slave		
7	LPCBSY	0	R/W	—	<p>LPC Busy</p> <p>Indicates that the host interface is processing a transfer cycle.</p> <p>0: Host interface is in transfer cycle wait state</p> <ul style="list-style-type: none"> • Bus idle, or transfer cycle not subject to processing is in progress • Cycle type or address indeterminate during transfer cycle <p>[Clearing conditions]</p> <ul style="list-style-type: none"> • LPC hardware reset or LPC software reset • LPC hardware shutdown or LPC software shutdown • Forced termination (abort) of transfer cycle subject to processing • Normal termination of transfer cycle subject to processing <p>1: Host interface is performing transfer cycle processing</p> <p>[Setting condition]</p> <ul style="list-style-type: none"> • Match of cycle type and address
6	CLKREQ	0	R	—	<p>LCLK Request</p> <p>Indicates that the host interface's SERIRQ output is requesting a restart of LCLK.</p> <p>0: No LCLK restart request</p> <p>[Clearing conditions]</p> <ul style="list-style-type: none"> • LPC hardware reset or LPC software reset • LPC hardware shutdown or LPC software shutdown • SERIRQ is set to continuous mode • There are no further interrupts for transfer to the host in quiet mode <p>1: LCLK restart request issued</p> <p>[Setting condition]</p> <ul style="list-style-type: none"> • In quiet mode, SERIRQ interrupt output becomes necessary while LCLK is stopped

Bit	Bit Name	Initial Value	R/W		Description
			Slave	Host	
5	IRQBSY	0	R	—	<p>SERIRQ Busy</p> <p>Indicates that the host interface's SERIRQ signal is engaged in transfer processing.</p> <p>0: SERIRQ transfer frame wait state [Clearing conditions]</p> <ul style="list-style-type: none"> • LPC hardware reset or LPC software reset • LPC hardware shutdown or LPC software shutdown • End of SERIRQ transfer frame <p>1: SERIRQ transfer processing in progress [Setting condition]</p> <ul style="list-style-type: none"> • Start of SERIRQ transfer frame
4	LRSTB	0	—	—	<p>LPC Software Reset Bit</p> <p>Resets the host interface. For the scope of initialization by an LPC reset, see section 15.4.4, Host Interface Shutdown Function (LPCPD).</p> <p>0: Normal state [Clearing conditions]</p> <ul style="list-style-type: none"> • Writing 0 • LPC hardware reset <p>1: LPC software reset state [Setting condition]</p> <ul style="list-style-type: none"> • Writing 1 after reading LRSTB = 0

Bit	Bit Name	Initial Value	R/W		Description
			Slave	Host	
3	SDWNB	0	R/W	—	<p>LPC Software Shutdown Bit</p> <p>Controls host interface shutdown. For details of the LPC shutdown function, and the scope of initialization by an LPC reset and an LPC shutdown, see section 15.4.4, Host Interface Shutdown Function (LPCPD).</p> <p>0: Normal state [Clearing conditions]</p> <ul style="list-style-type: none"> • Writing 0 • LPC hardware reset or LPC software reset • LPC hardware shutdown • LPC hardware shutdown release (rising edge of $\overline{\text{LPCPD}}$ signal when $\text{SDWNE} = 0$) <p>1: LPC software shutdown state [Setting condition]</p> <ul style="list-style-type: none"> • Writing 1 after reading $\text{SDWNB} = 0$
2	PMEB	0	R/W	—	<p>PME Output Bit</p> <p>Controls PME output in combination with the PMEE bit. For details, refer to description on the PMEE bit in HICR0.</p>
1	LSMIB	0	R/W	—	<p>LSMI Output Bit</p> <p>Controls LSMI output in combination with the LSMIE bit. For details, refer to description on the LSMIE bit in HICR0.</p>
0	LSCIB	0	R/W	—	<p>LSCI output Bit</p> <p>Controls LSCI output in combination with the LSCIE bit. For details, refer to description on the LSCIE bit in HICR0.</p>

15.3.2 Host Interface Control Registers 2 and 3 (HICR2, HICR3)

Bits 6 to 0 in HICR2 control interrupts from the host interface (LPC) module to the slave processor (this LSI). Bit 7 in HICR2 and HICR3 monitor host interface pin states.

The pin states can be monitored regardless of the host interface operating state or the operating state of the functions that use pin multiplexing.

- HICR2

Bit	Bit Name	Initial Value	R/W		Description
			Slave	Host	
7	GA20	Undefined	R	—	GA20 Pin Monitor
6	LRST	0	R/(W)*	—	LPC Reset Interrupt Flag This bit is a flag that generates an ERRRI interrupt when an LPC hardware reset occurs. 0: [Clearing conditions] <ul style="list-style-type: none"> • Writing 0 after reading LRST = 1 1: [Setting condition] <ul style="list-style-type: none"> • LRESET pin falling edge detection
5	SDWN	0	R/(W)*	—	LPC Shutdown Interrupt Flag This bit is a flag that generates an ERRRI interrupt when an LPC hardware shutdown request is generated. 0: [Clearing conditions] <ul style="list-style-type: none"> • Writing 0 after reading SDWN = 1 • LPC hardware reset and LPC software reset 1: [Setting condition] <ul style="list-style-type: none"> • LPCPD pin falling edge detection
4	ABRT	0	R/(W)*	—	LPC Abort Interrupt Flag This bit is a flag that generates an ERRRI interrupt when a forced termination (abort) of an LPC transfer cycle occurs. 0: [Clearing conditions] <ul style="list-style-type: none"> • Writing 0 after reading ABRT = 1 • LPC hardware reset and LPC software reset • LPC hardware shutdown and LPC software shutdown 1: [Setting condition] <ul style="list-style-type: none"> • LFRAME pin falling edge detection during LPC transfer cycle

Bit	Bit Name	Initial Value	R/W		Description
			Slave	Host	
3	IBFIE3	0	R/W	—	<p>IDR3 and TWR Receive Completion Interrupt Enable</p> <p>Enables or disables IBFI3 interrupt to the slave processor (this LSI).</p> <p>0: Input data register IDR3 and TWR receive completed interrupt requests disabled</p> <p>1: [When TWRIE = 0 in LADR3] Input data register (IDR3) receive completed interrupt requests enabled</p> <p>[When TWRIE = 1 in LADR3] Input data register (IDR3) and TWR receive completed interrupt requests enabled</p>
2	IBFIE2	0	R/W	—	<p>IDR2 Receive Completion Interrupt Enable</p> <p>Enables or disables IBFI2 interrupt to the slave processor (this LSI).</p> <p>0: Input data register (IDR2) receive completed interrupt requests disabled</p> <p>1: Input data register (IDR2) receive completed interrupt requests enabled</p>
1	IBFIE1	0	R/W	—	<p>IDR1 Receive Completion Interrupt Enable</p> <p>Enables or disables IBFI1 interrupt to the slave processor (this LSI).</p> <p>0: Input data register (IDR1) receive completed interrupt requests disabled</p> <p>1: Input data register (IDR1) receive completed interrupt requests enabled</p>
0	ERRIE	0	R/W	—	<p>Error Interrupt Enable</p> <p>Enables or disables ERRI interrupt to the slave processor (this LSI).</p> <p>0: Error interrupt requests disabled</p> <p>1: Error interrupt requests enabled</p>

Note: * Only 0 can be written to bits 6 to 4, to clear the flag.

- HICR3

Bit	Bit Name	Initial Value	R/W		Description
			Slave	Host	
7	LFRAME	Undefined	R	—	$\overline{\text{LFRAME}}$ Pin Monitor
6	CLKRUN	Undefined	R	—	$\overline{\text{CLKRUN}}$ Pin Monitor
5	SERIRQ	Undefined	R	—	$\overline{\text{SERIRQ}}$ Pin Monitor
4	LRESET	Undefined	R	—	$\overline{\text{LRESET}}$ Pin Monitor
3	LPCPD	Undefined	R	—	$\overline{\text{LPCPD}}$ Pin Monitor
2	PME	Undefined	R	—	$\overline{\text{PME}}$ Pin Monitor
1	LSMI	Undefined	R	—	$\overline{\text{LSMI}}$ Pin Monitor
0	LSCI	Undefined	R	—	$\overline{\text{LSCI}}$ Pin Monitor

15.3.3 LPC Channel 3 Address Register (LADR3)

LADR3 comprises two 8-bit readable/writable registers that perform LPC channel-3 host address setting and control the operation of the bidirectional data registers. The contents of the address field in LADR3 must not be changed while channel 3 is operating (while LPC3E is set to 1).

- LADR3H

Bit	Bit Name	Initial Value	R/W	Description
7	Bit 15	0	R/W	Channel 3 Address Bits 15 to 8:
6	Bit 14	0	R/W	When LPC3E = 1, an I/O address received in an LPC I/O cycle is compared with the contents of LADR3. When determining an IDR3, ODR3, or STR3 address match, bit 0 of LADR3 is regarded as 0, and the value of bit 2 is ignored. When determining a TWR0 to TWR15 address match, bit 4 of LADR3 is inverted, and the values of bits 3 to 0 are ignored. Register selection according to the bits ignored in address match determination is as shown in table 15.2.
5	Bit 13	0	R/W	
4	Bit 12	0	R/W	
3	Bit 11	0	R/W	
2	Bit 10	0	R/W	
1	Bit 9	0	R/W	
0	Bit 8	0	R/W	

- LADR3L

Bit	Bit Name	Initial Value	R/W	Description
7	Bit 7	0	R/W	Channel 3 Address Bits 7 to 3
6	Bit 6	0	R/W	
5	Bit 5	0	R/W	
4	Bit 4	0	R/W	
3	Bit 3	0	R/W	
2	—	0	R/W	Reserved This bit is readable/writable, however, only 0 should be written to this bit.
1	Bit 1	0	R/W	Channel 3 Address Bit 1
0	TWRE	0	R/W	Bidirectional Data Register Enable Enables or disables bidirectional data register operation. 0: TWR operation is disabled TWR-related I/O address match determination is halted 1: TWR operation is enabled

Table 15.2 Register Selection

I/O Address					Transfer Cycle	Host Register Selection
Bit 4	Bit 3	Bit 2	Bit 1	Bit 0		
Bit 4	Bit 3	0	Bit 1	0	I/O write	IDR3 write, $C/\overline{D}3 \leftarrow 0$
Bit 4	Bit 3	1	Bit 1	0	I/O write	IDR3 write, $C/\overline{D}3 \leftarrow 1$
Bit 4	Bit 3	0	Bit 1	0	I/O read	ODR3 read
Bit 4	Bit 3	1	Bit 1	0	I/O read	STR3 read
$\overline{\text{Bit 4}}$	0	0	0	0	I/O write	TWR0MW write
$\overline{\text{Bit 4}}$	0	0	0	1	I/O write	TWR1 to TWR15 write
	1	1	1	1		
$\overline{\text{Bit 4}}$	0	0	0	0	I/O read	TWR0SW read
$\overline{\text{Bit 4}}$	0	0	0	1	I/O read	TWR1 to TWR15 read
	1	1	1	1		

15.3.4 Input Data Registers 1 to 3 (IDR1 to IDR3)

The IDR registers are 8-bit read-only registers for the slave processor (this LSI), and 8-bit write-only registers for the host processor. The registers selected from the host according to the I/O address are shown in the following table. For information on IDR3 selection, see section 15.3.3, LPC Channel 3 Address Register (LADR3). Data transferred in an LPC I/O write cycle is written to the selected register. The state of bit 2 of the I/O address is latched into the C/\overline{D} bit in STR, to indicate whether the written information is a command or data. The initial values of IDR1 to IDR3 are undefined.

I/O Address					Transfer Cycle	Host Register Selection
Bits 15 to 4	Bit 3	Bit 2	Bit 1	Bit 0		
0000 0000 0110	0	0	0	0	I/O write	IDR1 write, $C/\overline{D}1 \leftarrow 0$
0000 0000 0110	0	1	0	0	I/O write	IDR1 write, $C/\overline{D}1 \leftarrow 1$
0000 0000 0110	0	0	1	0	I/O write	IDR2 write, $C/\overline{D}2 \leftarrow 0$
0000 0000 0110	0	1	1	0	I/O write	IDR2 write, $C/\overline{D}2 \leftarrow 1$

15.3.5 Output Data Registers 1 to 3 (ODR1 to ODR3)

The ODR registers are 8-bit readable/writable registers for the slave processor (this LSI), and 8-bit read-only registers for the host processor. The registers selected from the host according to the I/O address are shown in the following table. For information on ODR3 selection, see section 15.3.3, LPC Channel 3 Address Register (LADR3). In an LPC I/O read cycle, the data in the selected register is transferred to the host. The initial values of ODR1 to ODR3 are undefined.

Bits 15 to 4	I/O Address				Transfer Cycle	Host Register Selection
	Bit 3	Bit 2	Bit 1	Bit 0		
0000 0000 0110	0	0	0	0	I/O read	ODR1 read
0000 0000 0110	0	0	1	0	I/O read	ODR2 read

15.3.6 Bidirectional Data Registers 0 to 15 (TWR0 to TWR15)

The TWR registers are sixteen 8-bit readable/writable registers to both the slave processor (this LSI) and the host processor. In TWR0, however, two registers (TWR0MW and TWR0SW) are allocated to the same address for both the host address and the slave address. TWR0MW is a write-only register for the host processor, and a read-only register for the slave processor, while TWR0SW is a write-only register for the slave processor and a read-only register for the host processor. When the host and slave processors begin a write, after the respective TWR0 registers have been written to, access right arbitration for simultaneous access is performed by checking the status flags to see if those writes were valid. For the registers selected from the host according to the I/O address, see section 15.3.3, LPC Channel 3 Address Register (LADR3).

Data transferred in an LPC I/O write cycle is written to the selected register; in an LPC I/O read cycle, the data in the selected register is transferred to the host. The initial values of TWR0 to TWR15 are undefined.

15.3.7 Status Registers 1 to 3 (STR1 to STR3)

The STR registers are 8-bit registers that indicate status information during host interface processing. Bits 3, 1, and 0 of STR1 to STR3, and bits 7 to 4 of STR3, are read-only bits for both the host processor and the slave processor (this LSI). However, only 0 can be written to bit 0 of STR1 to STR3 and bits 6 and 4 of STR3, from the slave processor (this LSI), in order to clear the flags to 0. The registers selected from the host processor according to the I/O address are shown in the following table. For information on STR3 selection, see section 15.3.3, LPC Channel 3 Address Register (LADR3). In an LPC I/O read cycle, the data in the selected register is transferred to the host processor. The initial values of STR1 to STR3 are H'00.

I/O Address					Transfer Cycle	Host Register Selection
Bits 15 to 4	Bit 3	Bit 2	Bit 1	Bit 0		
0000 0000 0110	0	1	0	0	I/O read	STR1 read
0000 0000 0110	0	1	1	0	I/O read	STR2 read

- STR1

Bit	Bit Name	Initial Value	R/W		Description
			Slave	Host	
7	DBU17	0	R/W	R	Defined by User
6	DBU16	0	R/W	R	The user can use these bits as necessary.
5	DBU15	0	R/W	R	
4	DBU14	0	R/W	R	
3	C/D1	0	R	R	Command/Data When the host processor writes to an IDR register, bit 2 of the I/O address is written into this bit to indicate whether IDR contains data or a command. 0: Contents of data register (IDR) are data 1: Contents of data register (IDR) are a command
2	DBU12	0	R/W	R	Defined by User The user can use this bit as necessary.
1	IBF1	0	R	R	Input Buffer Full Set to 1 when the host processor writes to IDR. This bit is an internal interrupt source to the slave processor (this LSI). IBF is cleared to 0 when the slave processor reads IDR. The IBF1 flag setting and clearing conditions are different when the fast A20 gate is used. For details see table 15.3. 0: [Clearing condition] When the slave processor reads IDR 1: [Setting condition] When the host processor writes to IDR using I/O write cycle
0	OBF1	0	R/(W)*	R	Output Buffer Full Set to 1 when the slave processor (this LSI) writes to ODR. Cleared to 0 when the host processor reads ODR. 0: [Clearing condition] When the host processor reads ODR using I/O read cycle, or the slave processor writes 0 to the OBF bit 1: [Setting condition] When the slave processor writes to ODR

Note: * Only 0 can be written to clear the flag.

- STR2

Bit	Bit Name	Initial Value	R/W		Description
			Slave	Host	
7	DBU27	0	R/W	R	Defined by User
6	DBU26	0	R/W	R	The user can use these bits as necessary.
5	DBU25	0	R/W	R	
4	DBU24	0	R/W	R	
3	C/D $\bar{2}$	0	R	R	Command/Data When the host processor writes to an IDR register, bit 2 of the I/O address is written into this bit to indicate whether IDR contains data or a command. 0: Contents of data register (IDR) are data 1: Contents of data register (IDR) are a command
2	DBU22	0	R/W	R	Defined by User The user can use this bit as necessary.
1	IBF2	0	R	R	Input Buffer Full Set to 1 when the host processor writes to IDR. This bit is an internal interrupt source to the slave processor (this LSI). IBF is cleared to 0 when the slave processor reads IDR. The IBF1 flag setting and clearing conditions are different when the fast A20 gate is used. For details see table 15.3. 0: [Clearing condition] When the slave processor reads IDR 1: [Setting condition] When the host processor writes to IDR using I/O write cycle
0	OBF2	0	R/(W)*	R	Output Buffer Full Set to 1 when the slave processor (this LSI) writes to ODR. Cleared to 0 when the host processor reads ODR. 0: [Clearing condition] When the host processor reads ODR using I/O read cycle, or the slave processor writes 0 to the OBF bit 1: [Setting condition] When the slave processor writes to ODR

Note: * Only 0 can be written to clear the flag.

- STR3 (TWRE = 1 or SELSTR3 = 0)

Bit	Bit Name	Initial Value	R/W		Description
			Slave	Host	
7	IBF3B	0	R	R	<p>Bidirectional Data Register Input Buffer Full</p> <p>Set to 1 when the host processor writes to TWR15. This is an internal interrupt source to the slave processor (this LSI). IBF3B is cleared to 0 when the slave processor reads TWR15.</p> <p>0: [Clearing condition] When the slave processor reads TWR15</p> <p>1: [Setting condition] When the host processor writes to TWR15 using I/O write cycle</p>
6	OBF3B	0	R/(W)*	R	<p>Bidirectional Data Register Output Buffer Full</p> <p>Set to 1 when the slave processor (this LSI) writes to TWR15. OBF3B is cleared to 0 when the host processor reads TWR15.</p> <p>0: [Clearing condition] When the host processor reads TWR15 using I/O read cycle, or the slave processor writes 0 to the OBF3B bit</p> <p>1: [Setting condition] When the slave processor writes to TWR15</p>
5	MWMF	0	R	R	<p>Master Write Mode Flag</p> <p>Set to 1 when the host processor writes to TWR0. MWMF is cleared to 0 when the slave processor (this LSI) reads TWR15.</p> <p>0: [Clearing condition] When the slave processor reads TWR15</p> <p>1: [Setting condition] When the host processor writes to TWR0 using I/O write cycle while SWMF = 0</p>
4	SWMF	0	R/(W)*	R	<p>Slave Write Mode Flag</p> <p>Set to 1 when the slave processor (this LSI) writes to TWR0. In the event of simultaneous writes by the master and the slave, the master write has priority. SWMF is cleared to 0 when the host reads TWR15</p> <p>0: [Clearing condition] When the host processor reads TWR15 using I/O read cycle, or the slave processor writes 0 to the SWMF bit</p> <p>1: [Setting condition] When the slave processor writes to TWR0 while MWMF = 0</p>

Bit	Bit Name	Initial Value	R/W		Description
			Slave	Host	
3	C/D3	0	R	R	<p>Command/Data</p> <p>When the host processor writes to an IDR register, bit 2 of the I/O address is written into this bit to indicate whether IDR contains data or a command.</p> <p>0: Contents of data register (IDR) are data</p> <p>1: Contents of data register (IDR) are a command</p>
2	DBU32	0	R/W	R	<p>Defined by User</p> <p>The user can use this bit as necessary.</p>
1	IBF3A	0	R	R	<p>Input Buffer Full</p> <p>Set to 1 when the host processor writes to IDR. This bit is an internal interrupt source to the slave processor (this LSI). IBF is cleared to 0 when the slave processor reads IDR.</p> <p>The IBF1 flag setting and clearing conditions are different when the fast A20 gate is used. For details see table 15.3.</p> <p>0: [Clearing condition] When the slave processor reads IDR</p> <p>1: [Setting condition] When the host processor writes to IDR using I/O write cycle</p>
0	OBF3A	0	R/(W)*	R	<p>Output Buffer Full</p> <p>Set to 1 when the slave processor (this LSI) writes to ODR. OBF3A is cleared to 0 when the host processor reads ODR.</p> <p>0: [Clearing condition] When the host processor reads ODR using I/O read cycle, or the slave processor writes 0 to the OBF bit</p> <p>1: [Setting condition] When the slave processor writes to ODR</p>

Note: * Only 0 can be written to clear the flag.

- STR3 (TWRE = 0 and SELSTR3 = 1)

Bit	Bit Name	Initial Value	R/W		Description
			Slave	Host	
7	DBU37	0	R/W	R	Defined by User
6	DBU36	0	R/W	R	The user can use these bits as necessary.
5	DBU35	0	R/W	R	
4	DBU34	0	R/W	R	
3	C/D $\bar{3}$	0	R	R	Command/Data When the host processor writes to an IDR register, bit 2 of the I/O address is written into this bit to indicate whether IDR contains data or a command. 0: Contents of data register (IDR) are data 1: Contents of data register (IDR) are a command
2	DBU32	0	R/W	R	Defined by User The user can use this bit as necessary.
1	IBF3A	0	R	R	Input Buffer Full Set to 1 when the host processor writes to IDR. This bit is an internal interrupt source to the slave processor (this LSI). IBF is cleared to 0 when the slave processor reads IDR. The IBF1 flag setting and clearing conditions are different when the fast A20 gate is used. For details see table 15.3. 0: [Clearing condition] When the slave processor reads IDR 1: [Setting condition] When the host processor writes to IDR using I/O write cycle
0	OBF3A	0	R/(W)*	R	Output Buffer Full Set to 1 when the slave processor (this LSI) writes to ODR. OBF3A is cleared to 0 when the host processor reads ODR. 0: [Clearing condition] When the host processor reads ODR using I/O read cycle, or the slave processor writes 0 to the OBF bit 1: [Setting condition] When the slave processor writes to ODR

Note: * Only 0 can be written to clear the flag.

15.3.8 SERIRQ Control Registers 0 and 1 (SIRQCR0, SIRQCR1)

The SIRQCR registers contain status bits that indicate the SERIRQ operating mode and bits that specify SERIRQ interrupt sources.

- SIRQCR0

Bit	Bit Name	Initial Value	R/W		Description
			Slave	Host	
7	Q/C	0	R	—	<p>Quiet/Continuous Mode Flag</p> <p>Indicates the mode specified by the host at the end of an SERIRQ transfer cycle (stop frame).</p> <p>0: Continuous mode [Clearing conditions]</p> <ul style="list-style-type: none"> • LPC hardware reset, LPC software reset • Specification by SERIRQ transfer cycle stop frame <p>1: Quiet mode [Setting condition]</p> <ul style="list-style-type: none"> • Specification by SERIRQ transfer cycle stop frame.
6	SELREQ	0	R/W	—	<p>Start Frame Initiation Request Select</p> <p>Selects whether start frame initiation is requested when one or more interrupt requests are cleared, or when all interrupt requests are cleared, in quiet mode.</p> <p>0: Start frame initiation is requested when all interrupt requests are cleared in quiet mode.</p> <p>1: Start frame initiation is requested when one or more interrupt requests are cleared in quiet mode.</p>
5	IEDIR	0	R/W	—	<p>Interrupt Enable Direct Mode</p> <p>Specifies whether LPC channel 2 and channel 3 SERIRQ interrupt source (SMI, IRQ6, IRQ9 to IRQ11) generation is conditional upon OBF, or is controlled only by the host interrupt enable bit.</p> <p>0: Host interrupt is requested when host interrupt enable bit and corresponding OBF are both set to 1</p> <p>1: Host interrupt is requested when host interrupt enable bit is set to 1</p>

Bit	Bit Name	Initial Value	R/W		Description
			Slave	Host	
4	SMIE3B	0	R/W	—	<p>Host SMI Interrupt Enable 3B</p> <p>Enables or disables a host SMI interrupt request when OBF3B is set by a TWR15 write.</p> <p>0: Host SMI interrupt request by OBF3B and SMIE3B is disabled</p> <p>[Clearing conditions]</p> <ul style="list-style-type: none"> • Writing 0 to SMIE3B • LPC hardware reset, LPC software reset • Clearing OBF3B to 0 (when IEDIR = 0) <p>1: [When IEDIR = 0]</p> <p>Host SMI interrupt request by setting OBF3B to 1 is enabled</p> <p>[When IEDIR = 1]</p> <p>Host SMI interrupt is requested</p> <p>[Setting condition]</p> <ul style="list-style-type: none"> • Writing 1 after reading SMIE3B = 0
3	SMIE3A	0	R/W	—	<p>Host SMI Interrupt Enable 3A</p> <p>Enables or disables a host SMI interrupt request when OBF3A is set by an ODR3 write.</p> <p>0: Host SMI interrupt request by OBF3A and SMIE3A is disabled</p> <p>[Clearing conditions]</p> <ul style="list-style-type: none"> • Writing 0 to SMIE3A • LPC hardware reset, LPC software reset • Clearing OBF3A to 0 (when IEDIR = 0) <p>1: [When IEDIR = 0]</p> <p>Host SMI interrupt request by setting OBF3A to 1 is enabled</p> <p>[When IEDIR = 1]</p> <p>Host SMI interrupt is requested</p> <p>[Setting condition]</p> <ul style="list-style-type: none"> • Writing 1 after reading SMIE3A = 0

Bit	Bit Name	Initial Value	R/W		Description
			Slave	Host	
2	SMIE2	0	R/W	—	<p>Host SMI Interrupt Enable 2</p> <p>Enables or disables a host SMI interrupt request when OBF2 is set by an ODR2 write.</p> <p>0: Host SMI interrupt request by OBF2 and SMIE2 is disabled</p> <p>[Clearing conditions]</p> <ul style="list-style-type: none"> • Writing 0 to SMIE2 • LPC hardware reset, LPC software reset • Clearing OBF2 to 0 (when IEDIR = 0) <p>1: [When IEDIR = 0]</p> <p>Host SMI interrupt request by setting OBF2 to 1 is enabled</p> <p>[When IEDIR = 1]</p> <p>Host SMI interrupt is requested</p> <p>[Setting condition]</p> <ul style="list-style-type: none"> • Writing 1 after reading SMIE2 = 0
1	IRQ12E1	0	R/W	—	<p>Host IRQ12 Interrupt Enable 1</p> <p>Enables or disables a host IRQ12 interrupt request when OBF1 is set by an ODR1 write.</p> <p>0: Host IRQ12 interrupt request by OBF1 and IRQ12E1 is disabled</p> <p>[Clearing conditions]</p> <ul style="list-style-type: none"> • Writing 0 to IRQ12E1 • LPC hardware reset, LPC software reset • Clearing OBF1 to 0 <p>1: Host IRQ12 interrupt request by setting OBF1 to 1 is enabled</p> <p>[Setting condition]</p> <ul style="list-style-type: none"> • Writing 1 after reading IRQ12E1 = 0

Bit	Bit Name	Initial Value	R/W		Description
			Slave	Host	
0	IRQ1E1	0	R/W	—	<p>Host IRQ1 Interrupt Enable 1</p> <p>Enables or disables a host IRQ1 interrupt request when OBF1 is set by an ODR1 write.</p> <p>0: Host IRQ1 interrupt request by OBF1 and IRQ1E1 is disabled</p> <p>[Clearing conditions]</p> <ul style="list-style-type: none"> • Writing 0 to IRQ1E1 • LPC hardware reset, LPC software reset • Clearing OBF1 to 0 <p>1: Host IRQ1 interrupt request by setting OBF1 to 1 is enabled</p> <p>[Setting condition]</p> <ul style="list-style-type: none"> • Writing 1 after reading IRQ1E1 = 0

• SIRQCR1

Bit	Bit Name	Initial Value	R/W		Description
			Slave	Host	
7	IRQ11E3	0	R/W	—	<p>Host IRQ11 Interrupt Enable 3</p> <p>Enables or disables a host IRQ11 interrupt request when OBF3A is set by an ODR3 write.</p> <p>0: Host IRQ11 interrupt request by OBF3A and IRQ11E3 is disabled</p> <p>[Clearing conditions]</p> <ul style="list-style-type: none"> • Writing 0 to IRQ11E3 • LPC hardware reset, LPC software reset • Clearing OBF3A to 0 (when IEDIR = 0) <p>1: [When IEDIR = 0]</p> <p>Host IRQ11 interrupt request by setting OBF3A to 1 is enabled</p> <p>[When IEDIR = 1]</p> <p>Host IRQ11 interrupt is requested.</p> <p>[Setting condition]</p> <ul style="list-style-type: none"> • Writing 1 after reading IRQ11E3 = 0

Bit	Bit Name	Initial Value	R/W		Description
			Slave	Host	
6	IRQ10E3	0	R/W	—	<p>Host IRQ10 Interrupt Enable 3</p> <p>Enables or disables a host IRQ10 interrupt request when OBF3A is set by an ODR3 write.</p> <p>0: Host IRQ10 interrupt request by OBF3A and IRQ10E3 is disabled</p> <p>[Clearing conditions]</p> <ul style="list-style-type: none"> • Writing 0 to IRQ10E3 • LPC hardware reset, LPC software reset • Clearing OB3FA to 0 (when IEDIR = 0) <p>1: [When IEDIR = 0]</p> <p>Host IRQ10 interrupt request by setting OBF3A to 1 is enabled</p> <p>[When IEDIR = 1]</p> <p>Host IRQ10 interrupt is requested.</p> <p>[Setting condition]</p> <ul style="list-style-type: none"> • Writing 1 after reading IRQ10E3 = 0
5	IRQ9E3	0	R/W	—	<p>Host IRQ9 Interrupt Enable 3</p> <p>Enables or disables a host IRQ9 interrupt request when OBF3A is set by an ODR3 write.</p> <p>0: Host IRQ9 interrupt request by OBF3A and IRQ9E3 is disabled</p> <p>[Clearing conditions]</p> <ul style="list-style-type: none"> • Writing 0 to IRQ9E3 • LPC hardware reset, LPC software reset • Clearing OBF3A to 0 (when IEDIR = 0) <p>1: [When IEDIR = 0]</p> <p>Host IRQ9 interrupt request by setting OBF3A to 1 is enabled</p> <p>[When IEDIR = 1]</p> <p>Host IRQ9 interrupt is requested.</p> <p>[Setting condition]</p> <ul style="list-style-type: none"> • Writing 1 after reading IRQ9E3 = 0

Bit	Bit Name	Initial Value	R/W		Description
			Slave	Host	
4	IRQ6E3	0	R/W	—	<p>Host IRQ6 Interrupt Enable 3</p> <p>Enables or disables a host IRQ6 interrupt request when OBF3A is set by an ODR3 write.</p> <p>0: Host IRQ6 interrupt request by OBF3A and IRQ6E3 is disabled</p> <p>[Clearing conditions]</p> <ul style="list-style-type: none"> • Writing 0 to IRQ6E3 • LPC hardware reset, LPC software reset • Clearing OBF3A to 0 (when IEDIR = 0) <p>1: [When IEDIR = 0]</p> <p>Host IRQ6 interrupt request by setting OBF3A to 1 is enabled</p> <p>[When IEDIR = 1]</p> <p>Host IRQ6 interrupt is requested.</p> <p>[Setting condition]</p> <ul style="list-style-type: none"> • Writing 1 after reading IRQ6E3 = 0
3	IRQ11E2	0	R/W	—	<p>Host IRQ11 Interrupt Enable 2</p> <p>Enables or disables a host IRQ11 interrupt request when OBF2 is set by an ODR2 write.</p> <p>0: Host IRQ11 interrupt request by OBF2 and IRQ11E2 is disabled</p> <p>[Clearing conditions]</p> <ul style="list-style-type: none"> • Writing 0 to IRQ11E2 • LPC hardware reset, LPC software reset • Clearing OBF2 to 0 (when IEDIR = 0) <p>1: [When IEDIR = 0]</p> <p>Host IRQ11 interrupt request by setting OBF2 to 1 is enabled</p> <p>[When IEDIR = 1]</p> <p>Host IRQ11 interrupt is requested.</p> <p>[Setting condition]</p> <ul style="list-style-type: none"> • Writing 1 after reading IRQ11E2 = 0

Bit	Bit Name	Initial Value	R/W		Description
			Slave	Host	
2	IRQ10E2	0	R/W	—	<p>Host IRQ10 Interrupt Enable 2</p> <p>Enables or disables a host IRQ10 interrupt request when OBF2 is set by an ODR2 write.</p> <p>0: Host IRQ10 interrupt request by OBF2 and IRQ10E2 is disabled</p> <p>[Clearing conditions]</p> <ul style="list-style-type: none"> • Writing 0 to IRQ10E2 • LPC hardware reset, LPC software reset • Clearing OBF2 to 0 (when IEDIR = 0) <p>1: [When IEDIR = 0]</p> <p>Host IRQ10 interrupt request by setting OBF2 to 1 is enabled</p> <p>[When IEDIR = 1]</p> <p>Host IRQ10 interrupt is requested.</p> <p>[Setting condition]</p> <ul style="list-style-type: none"> • Writing 1 after reading IRQ10E2 = 0
1	IRQ9E2	0	R/W	—	<p>Host IRQ9 Interrupt Enable 2</p> <p>Enables or disables a host IRQ9 interrupt request when OBF2 is set by an ODR2 write.</p> <p>0: Host IRQ9 interrupt request by OBF2 and IRQ9E2 is disabled</p> <p>[Clearing conditions]</p> <ul style="list-style-type: none"> • Writing 0 to IRQ9E2 • LPC hardware reset, LPC software reset • Clearing OBF2 to 0 (when IEDIR = 0) <p>1: [When IEDIR = 0]</p> <p>Host IRQ9 interrupt request by setting OBF2 to 1 is enabled</p> <p>[When IEDIR = 1]</p> <p>Host IRQ9 interrupt is requested.</p> <p>[Setting condition]</p> <ul style="list-style-type: none"> • Writing 1 after reading IRQ9E2 = 0

Bit	Bit Name	Initial		Host	Description
		Value	Slave		
0	IRQ6E2	0	R/W	—	<p>Host IRQ6 Interrupt Enable 2</p> <p>Enables or disables a host IRQ6 interrupt request when OBF2 is set by an ODR2 write.</p> <p>0: Host IRQ6 interrupt request by OBF2 and IRQ6E2 is disabled</p> <p>[Clearing conditions]</p> <ul style="list-style-type: none"> • Writing 0 to IRQ6E2 • LPC hardware reset, LPC software reset • Clearing OBF2 to 0 (when IEDIR = 0) <p>1: [When IEDIR = 0] Host IRQ6 interrupt request by setting OBF2 to 1 is enabled</p> <p>[When IEDIR = 1] Host IRQ6 interrupt is requested.</p> <p>[Setting condition]</p> <ul style="list-style-type: none"> • Writing 1 after reading IRQ6E2 = 0

15.3.9 Host Interface Select Register (HISEL)

HISEL selects the function of bits 7 to 4 in STR3 and specifies the output of the host interrupt request signal of each frame.

Bit	Bit Name	Initial Value	R/W		Description
			Slave	Host	
7	SELSTR3	0	W		<p>STR3 Register Function Select 3</p> <p>Selects the function of bits 7 to 4 in STR3 in combination with the TWRE bit in LADR3L. See description on STR3 in section 15.3.7, Status Registers 1 to 3 (STR1 to STR3), for details.</p> <p>0: Bits 7 to 4 in STR3 are status bits of the host interface.</p> <p>1: [When TWRE = 1] Bits 7 to 4 in STR3 are status bits of the host interface.</p> <p>[When TWRE = 0] Bits 7 to 4 in STR3 are user bits.</p>
6	SELIRQ11	0	W	—	SERIRQ Output Select
5	SELIRQ10	0	W	—	Selects the pin output status of host interrupt requests (HIRQ11, HIRQ10, HIRQ9, HIRQ6, SMI, HIRQ12, and HIRQ1) of the LPC.
4	SELIRQ9	0	W	—	
3	SELIRQ6	0	W	—	0: [When host interrupt request is cleared] SERIRQ pin output is in the high-impedance state.
2	SELSMI	0	W	—	
1	SELIRQ12	1	W	—	[When host interrupt request is set] SERIRQ pin output is 0.
0	SELIRQ1	1	W	—	<p>[When host interrupt request is cleared] SERIRQ pin output is 0.</p> <p>[When host interrupt request is set] SERIRQ pin output is in the high-impedance state.</p>

15.4 Operation

15.4.1 Host Interface Activation

The host interface is activated by setting one of bits LPC3E to LPC1E in HICR0 to 1 in single-chip mode. When the host interface is activated, the related I/O ports (ports 37 to 30, ports 83 and 82) function as dedicated host interface input/output pins. In addition, setting the FGA20E, PMEE, LSMIE, and LSCIE bits to 1 adds the related I/O ports (ports 81 and 80, ports B0 and B1) to the host interface's input/output pins.

Use the following procedure to activate the host interface after a reset release.

1. Read the signal line status and confirm that the LPC module can be connected. Also check that the LPC module is initialized internally.
2. When using channel 3, set LADR3 to determine the channel 3 I/O address and whether bidirectional data registers are to be used.
3. Set the enable bit (LPC3E to LPC1E) for the channel to be used.
4. Set the enable bits (GA20E, PMEE, LSMIE, and LSCIE) for the additional functions to be used.
5. Set the selection bits for other functions (SDWNE, IEDIR).
6. As a precaution, clear the interrupt flags (LRST, SDWN, ABRT, OBF). Read IDR or TWR15 to clear IBF.
7. Set interrupt enable bits (IBFIE3 to IBFIE1, ERRIE) as necessary.

15.4.2 LPC I/O Cycles

There are ten kinds of LPC transfer cycle: memory read, memory write, I/O read, I/O write, DMA read, DMA write, bus master memory read, bus master memory write, bus master I/O read, and bus master I/O write. Of these, the chip's LPC supports only I/O read and I/O write cycles.

An LPC transfer cycle is started when the $\overline{\text{LFRAME}}$ signal goes low in the bus idle state. If the $\overline{\text{LFRAME}}$ signal goes low when the bus is not idle, this means that a forced termination (abort) of the LPC transfer cycle has been requested.

In an I/O read cycle or I/O write cycle, transfer is carried out using LAD3 to LAD0 in the following order, in synchronization with LCLK. The host can be made to wait by sending back a value other than B'0000 in the slave's synchronization return cycle, but with the chip's LPC a value of B'0000 is always returned.

If the received address matches the host address in an LPC register (IDR, ODR, STR, TWR), the host interface enters the busy state; it returns to the idle state by output of a state count 12 turnaround. Register and flag changes are made at this timing, so in the event of a transfer cycle forced termination (abort) before state #12, registers and flags are not changed.

State Count	I/O Read Cycle			I/O Write Cycle		
	Contents	Drive Source	Value (3 to 0)	Contents	Drive Source	Value (3 to 0)
1	Start	Host	0000	Start	Host	0000
2	Cycle type/direction	Host	0000	Cycle type/direction	Host	0010
3	Address 1	Host	Bits 15 to 12	Address 1	Host	Bits 15 to 12
4	Address 2	Host	Bits 11 to 8	Address 2	Host	Bits 11 to 8
5	Address 3	Host	Bits 7 to 4	Address 3	Host	Bits 7 to 4
6	Address 4	Host	Bits 3 to 0	Address 4	Host	Bits 3 to 0
7	Turnaround (recovery)	Host	1111	Data 1	Host	Bits 3 to 0
8	Turnaround	None	ZZZZ	Data 2	Host	Bits 7 to 4
9	Synchronization	Slave	0000	Turnaround (recovery)	Host	1111
10	Data 1	Slave	Bits 3 to 0	Turnaround	None	ZZZZ
11	Data 2	Slave	Bits 7 to 4	Synchronization	Slave	0000
12	Turnaround (recovery)	Slave	1111	Turnaround (recovery)	Slave	1111
13	Turnaround	None	ZZZZ	Turnaround	None	ZZZZ

The timing of the $\overline{\text{LFRAME}}$, LCLK, and LAD signals is shown in figures 15.2 and 15.3.

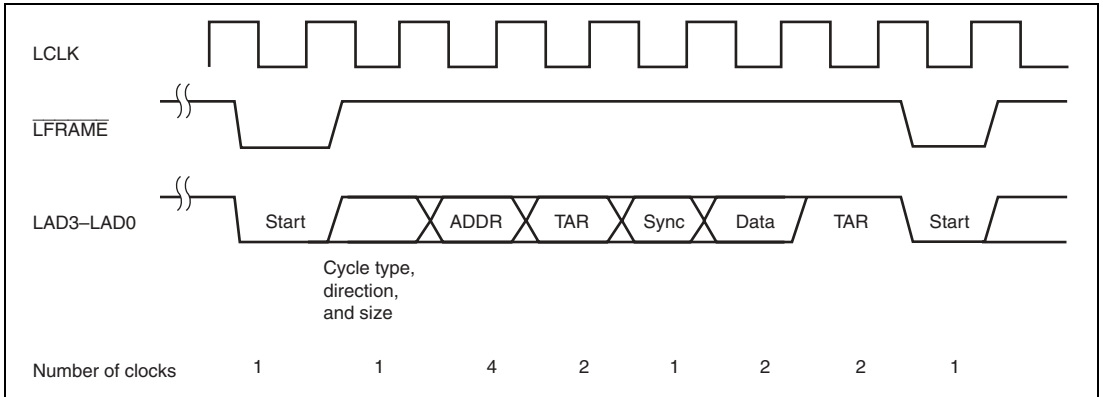

Figure 15.2 Typical $\overline{\text{LFRAME}}$ Timing

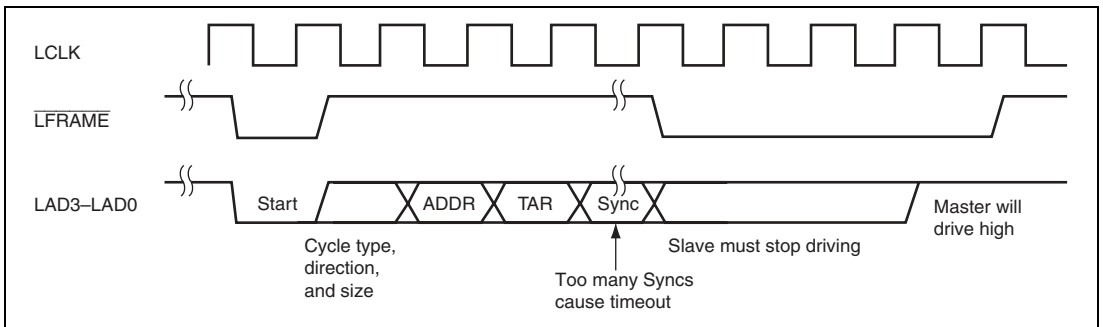

Figure 15.3 Abort Mechanism

15.4.3 A20 Gate

The A20 gate signal can mask address A20 to emulate an addressing mode used by personal computers with an 8086*-family CPU. A regular-speed A20 gate signal can be output under firmware control. The fast A20 gate function that is speeded up by hardware is enabled by setting the FGA20E bit to 1 in HICR0.

Note: An Intel microprocessor

Regular A20 Gate Operation: Output of the A20 gate signal can be controlled by an H'D1 command followed by data. When the slave processor (this LSI) receives data, it normally uses an interrupt routine activated by the IBF1 interrupt to read IDR1. At this time, firmware copies bit 1 of data following an H'D1 command and outputs it at the gate A20 pin.

Fast A20 Gate Operation: The internal state of GA20 output is initialized to 1 when FGA20E = 0. When the FGA20E bit is set to 1, P81/GA20 is used for output of a fast A20 gate signal. The state of the P81/GA20 pin can be monitored by reading the GA20 bit in HICR2.

The initial output from this pin will be a logic 1, which is the initial value. Afterward, the host processor can manipulate the output from this pin by sending commands and data. This function is only available via the IDR1 register. The host interface decodes commands input from the host. When an H'D1 host command is detected, bit 1 of the data following the host command is output from the GA20 output pin. This operation does not depend on firmware or interrupts, and is faster than the regular processing using interrupts. Table 15.3 shows the conditions that set and clear GA20 (P81). Figure 15.4 shows the GA20 output in flowchart form. Table 15.4 indicates the GA20 output signal values.

Table 15.3 GA20 (P81) Set/Clear Timing

Pin Name	Setting Condition	Clearing Condition
GA20 (P81)	When bit 1 of the data that follows an H'D1 host command is 1	When bit 1 of the data that follows an H'D1 host command is 0

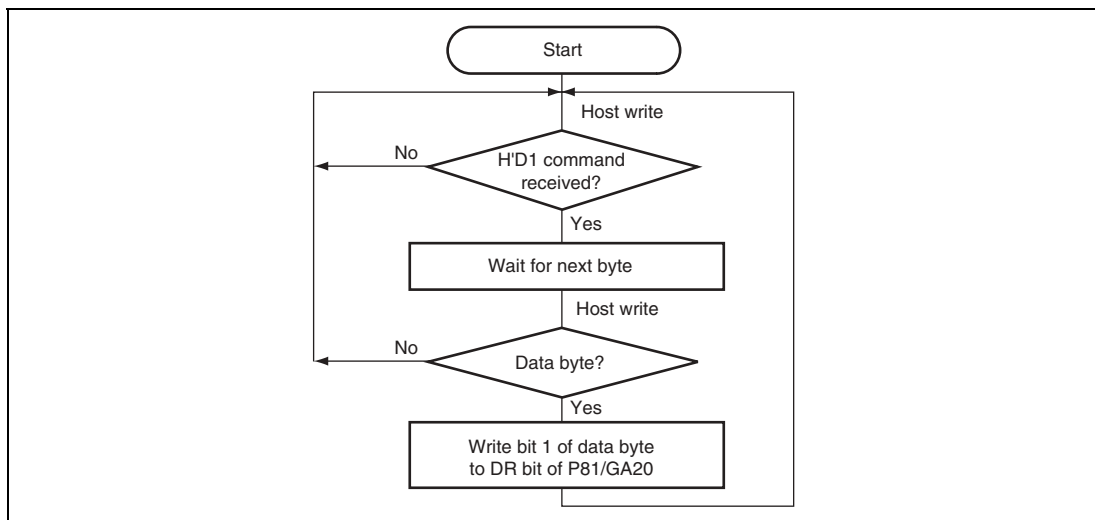

Figure 15.4 GA20 Output

Table 15.4 Fast A20 Gate Output Signals

HA0	Data/Command	Internal CPU Interrupt Flag (IBF)	GA20 (P81)	Remarks
1	H'D1 command	0	Q	Turn-on sequence
0	1 data* ¹	0	1	
1	H'FF command	0	Q (1)	
1	H'D1 command	0	Q	Turn-off sequence
0	0 data* ²	0	0	
1	H'FF command	0	Q (0)	
1	H'D1 command	0	Q	Turn-on sequence (abbreviated form)
0	1 data* ¹	0	1	
1/0	Command other than H'FF and H'D1	1	Q (1)	
1	H'D1 command	0	Q	Turn-off sequence (abbreviated form)
0	0 data* ²	0	0	
1/0	Command other than H'FF and H'D1	1	Q (0)	
1	H'D1 command	0	Q	Cancelled sequence
1	Command other than H'D1	1	Q	
1	H'D1 command	0	Q	Retriggered sequence
1	H'D1 command	0	Q	
1	H'D1 command	0	Q	Consecutively executed sequences
0	Any data	0	1/0	
1	H'D1 command	0	Q (1/0)	

Notes: 1. Arbitrary data with bit 1 set to 1.
 2. Arbitrary data with bit 1 cleared to 0.

15.4.4 Host Interface Shutdown Function (LPCPD)

The host interface can be placed in the shutdown state according to the state of the $\overline{\text{LPCPD}}$ pin. There are two kinds of host interface shutdown state: LPC hardware shutdown and LPC software shutdown. The LPC hardware shutdown state is controlled by the $\overline{\text{LPCPD}}$ pin, while the software shutdown state is controlled by the SDWNB bit. In both states, the host interface enters the reset state by itself, and is no longer affected by external signals other than the $\overline{\text{LRESET}}$ and $\overline{\text{LPCPD}}$ signals.

Placing the slave processor in sleep mode or software standby mode is effective in reducing current dissipation in the shutdown state. If software standby mode is set, some means must be provided for exiting software standby mode before clearing the shutdown state with the $\overline{\text{LPCPD}}$ signal.

If the SDWNE bit has been set to 1 beforehand, the LPC hardware shutdown state is entered at the same time as the $\overline{\text{LPCPD}}$ signal falls, and prior preparation is not possible. If the LPC software shutdown state is set by means of the SDWNB bit, on the other hand, the LPC software shutdown state cannot be cleared at the same time as the rise of the $\overline{\text{LPCPD}}$ signal. Taking these points into consideration, the following operating procedure uses a combination of LPC software shutdown and LPC hardware shutdown.

1. Clear the SDWNE bit to 0.
2. Set the ERRIE bit to 1 and wait for an interrupt by the SDWN flag.
3. When an ERRI interrupt is generated by the SDWN flag, check the host interface internal status flags and perform any necessary processing.
4. Set the SDWNB bit to 1 to set LPC software standby mode.
5. Set the SDWNE bit to 1 and make a transition to LPC hardware standby mode. The SDWNB bit is cleared automatically.
6. Check the state of the $\overline{\text{LPCPD}}$ signal to make sure that the $\overline{\text{LPCPD}}$ signal has not risen during steps 3 to 5. If the signal has risen, clear SDWNE to 0 to return to the state in step 1.
7. Place the slave processor in sleep mode or software standby mode as necessary.
8. If software standby mode has been set, exit software standby mode by some means independent of the LPC.
9. When a rising edge is detected in the $\overline{\text{LPCPD}}$ signal, the SDWNE bit is automatically cleared to 0. If the slave processor has been placed in sleep mode, the mode is exited by means of $\overline{\text{LRESET}}$ signal input, on completion of the LPC transfer cycle, or by some other means.

Table 15.5 shows the scope of the host interface pin shutdown.

Table 15.5 Scope of Host Interface Pin Shutdown

Abbreviation	Port	Scope of Shutdown	I/O	Notes
LAD3 to LAD0	P33–P30	O	I/O	Hi-Z
$\overline{\text{LFRAME}}$	P34	O	Input	Hi-Z
$\overline{\text{LRESET}}$	P35	×	Input	LPC hardware reset function is active
LCLK	P36	O	Input	Hi-Z
SERIRQ	P37	O	I/O	Hi-Z
LSCI	PB1	Δ	I/O	Hi-Z, only when LSCIE = 1
$\overline{\text{LSMI}}$	PB0	Δ	I/O	Hi-Z, only when LSMIE = 1
$\overline{\text{PME}}$	P80	Δ	I/O	Hi-Z, only when PMEE = 1
GA20	P81	Δ	I/O	Hi-Z, only when FGA20E = 1
$\overline{\text{CLKRUN}}$	P82	O	I/O	Hi-Z
$\overline{\text{LPCPD}}$	P83	×	Input	Needed to clear shutdown state

[Legend]

- O: Pin that is shutdown by the shutdown function
- Δ: Pin that is shutdown only when the LPC function is selected by register setting
- ×: Pin that is not shutdown

In the LPC shutdown state, the LPC's internal state and some register bits are initialized. The order of priority of LPC shutdown and reset states is as follows.

1. System reset (reset by $\overline{\text{STBY}}$ or $\overline{\text{RES}}$ pin input, or WDT0 overflow)
 - All register bits, including bits LPC3E to LPC1E, are initialized.
2. LPC hardware reset (reset by $\overline{\text{LRESET}}$ pin input)
 - LRSTB, SDWNE, and SDWNB bits are cleared to 0.
3. LPC software reset (reset by LRSTB)
 - SDWNE and SDWNB bits are cleared to 0.
4. LPC hardware shutdown
 - SDWNB bit is cleared to 0.
5. LPC software shutdown

The scope of the initialization in each mode is shown in table 15.6.

Table 15.6 Scope of Initialization in Each Host Interface Mode

Items Initialized	System Reset	LPC Reset	LPC Shutdown
LPC transfer cycle sequencer (internal state), LPCBSY and ABRT flags	Initialized	Initialized	Initialized
SERIRQ transfer cycle sequencer (internal state), CLKREQ and IRQBSY flags	Initialized	Initialized	Initialized
Host interface flags (IBF1, IBF2, IBF3A, IBF3B, MWMF, C/ \bar{D} 1, C/ \bar{D} 2, C/ \bar{D} 3, OBF1, OBF2, OBF3A, OBF3B, SWMF, DBU), GA20 (internal state)	Initialized	Initialized	Retained
Host interrupt enable bits (IRQ1E1, IRQ12E1, SMIE2, IRQ6E2, IRQ9E2 to IRQ11E2, SMIE3B, SMIE3A, IRQ6E3, IRQ9E3 to IRQ11E3), Q/ \bar{C} flag, SELREQ bit	Initialized	Initialized	Retained
LRST flag	Initialized (0)	Can be set/cleared	Can be set/cleared
SDWN flag	Initialized (0)	Initialized (0)	Can be set/cleared
LRSTB bit	Initialized (0)	HR: 0 SR: 1	0 (can be set)
SDWNB bit	Initialized (0)	Initialized (0)	HS: 0 SS: 1
SDWNE bit	Initialized (0)	Initialized (0)	HS: 1 SS: 0 or 1
Host interface operation control bits (LPC3E to LPC1E, FGA20E, LADR3, IBFIE1 to IBFIE3, PMEE, PMEB, LSMIE, LSMIB, LSCIE, LSCIB, TWRE, SELSTR3, SELIRQ1, SELSMI, SELIRQ6, SELIRQ9, SELIRQ10, SELIRQ11, SELIRQ12)	Initialized	Retained	Retained
$\overline{\text{LRESET}}$ signal	Input (port function)	Input	Input
$\overline{\text{LPCPD}}$ signal		Input	Input
LAD3 to LAD0, $\overline{\text{LFRAME}}$, LCLK, SERIRQ, $\overline{\text{CLKRUN}}$ signals		Input	Hi-Z
$\overline{\text{PM}}\bar{\text{E}}$, $\overline{\text{LSM}}\bar{\text{I}}$, LSCI, GA20 signals (when function is selected)		Output	Hi-Z
$\overline{\text{PM}}\bar{\text{E}}$, $\overline{\text{LSM}}\bar{\text{I}}$, LSCI, GA20 signals (when function is not selected)		Port function	Port function

Note: System reset: Reset by STBY input, RES input, or WDT overflow

LPC reset: Reset by LPC hardware reset (HR) or LPC software reset (SR)

LPC shutdown: Reset by LPC hardware shutdown (HS) or LPC software shutdown (SS)

Figure 15.5 shows the timing of the $\overline{\text{LPCPD}}$ and $\overline{\text{LRESET}}$ signals.

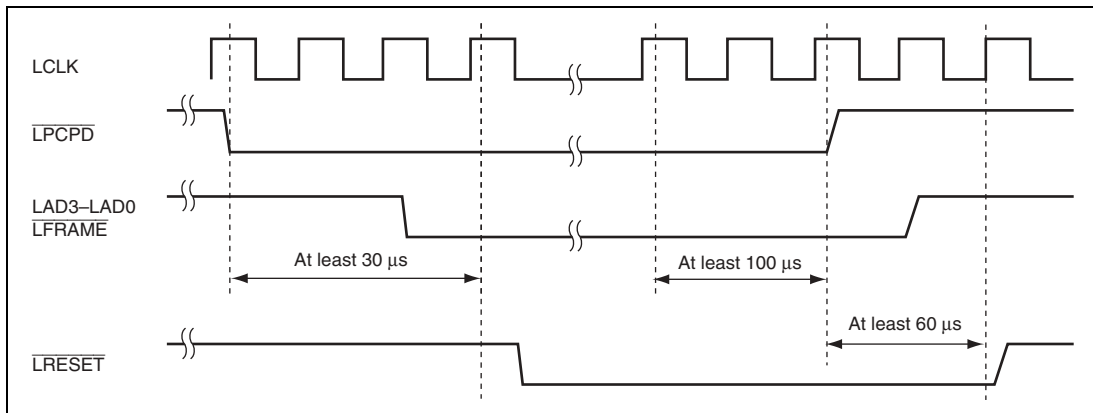

Figure 15.5 Power-Down State Termination Timing

15.4.5 Host Interface Serialized Interrupt Operation (SERIRQ)

A host interrupt request can be issued from the host interface by means of the SERIRQ pin. In a host interrupt request via the SERIRQ pin, LCLK cycles are counted from the start frame of the serialized interrupt transfer cycle generated by the host or a peripheral function, and a request signal is generated by the frame corresponding to that interrupt. The timing is shown in figure 15.6.

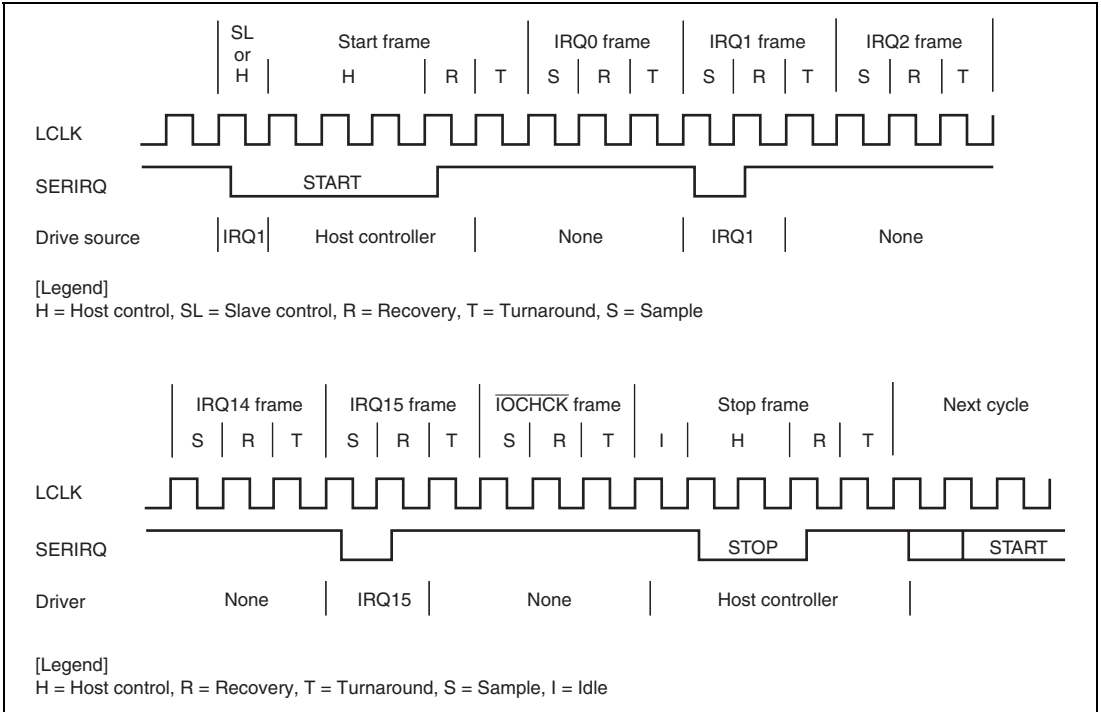

Figure 15.6 SERIRQ Timing

The serialized interrupt transfer cycle frame configuration is as follows. Two of the states comprising each frame are the recover state in which the SERIRQ signal is returned to the 1-level at the end of the frame, and the turnaround state in which the SERIRQ signal is not driven. The recover state must be driven by the host or slave processor that was driving the preceding state.

Serial Interrupt Transfer Cycle

Frame Count	Contents	Drive Source	Number of States	Notes
0	Start	Slave Host	6	In quiet mode only, slave drive possible in first state, then next 3 states 0-driven by host
1	IRQ0	Slave	3	
2	IRQ1	Slave	3	Drive possible in LPC channel 1
3	SMI	Slave	3	Drive possible in LPC channels 2 and 3
4	IRQ3	Slave	3	
5	IRQ4	Slave	3	
6	IRQ5	Slave	3	
7	IRQ6	Slave	3	Drive possible in LPC channels 2 and 3
8	IRQ7	Slave	3	
9	IRQ8	Slave	3	
10	IRQ9	Slave	3	Drive possible in LPC channels 2 and 3
11	IRQ10	Slave	3	Drive possible in LPC channels 2 and 3
12	IRQ11	Slave	3	Drive possible in LPC channels 2 and 3
13	IRQ12	Slave	3	Drive possible in LPC channel 1
14	IRQ13	Slave	3	
15	IRQ14	Slave	3	
16	IRQ15	Slave	3	
17	IOCHCK	Slave	3	
18	Stop	Host	Undefined	First, 1 or more idle states, then 2 or 3 states 0-driven by host 2 states: Quiet mode next 3 states: Continuous mode next

There are two modes—continuous mode and quiet mode—for serialized interrupts. The mode initiated in the next transfer cycle is selected by the stop frame of the serialized interrupt transfer cycle that ended before that cycle.

In continuous mode, the host initiates host interrupt transfer cycles at regular intervals. In quiet mode, the slave processor with interrupt sources requiring a request can also initiate an interrupt transfer cycle, in addition to the host. In quiet mode, since the host does not necessarily initiate interrupt transfer cycles, it is possible to suspend the clock (LCLK) supply and enter the power-down state. In order for a slave to transfer an interrupt request in this case, a request to restart the clock must first be issued to the host. For details see section 15.4.6, Host Interface Clock Start Request (CLKRUN).

15.4.6 Host Interface Clock Start Request (CLKRUN)

A request to restart the clock (LCLK) can be sent to the host processor by means of the $\overline{\text{CLKRUN}}$ pin. With LPC data transfer and SERIRQ in continuous mode, a clock restart is never requested since the transfer cycles are initiated by the host. With SERIRQ in quiet mode, when a host interrupt request is generated the $\overline{\text{CLKRUN}}$ signal is driven and a clock (LCLK) restart request is sent to the host. The timing for this operation is shown in figure 15.7.

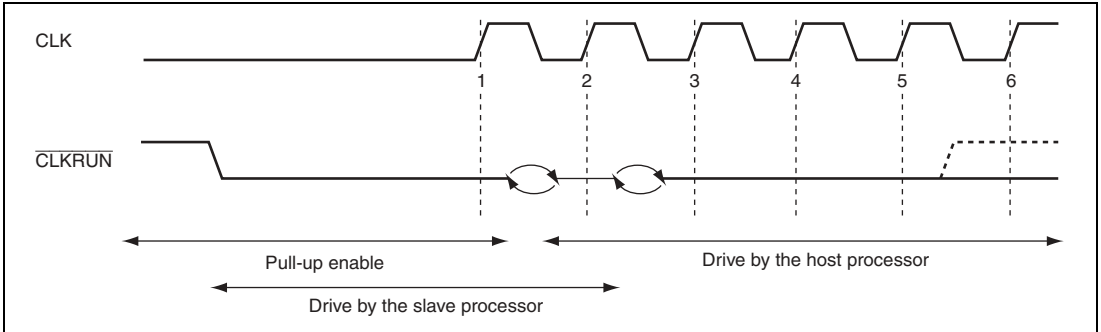

Figure 15.7 Clock Start Request Timing

Cases other than SERIRQ in quiet mode when clock restart is required must be handled with a different protocol, using the $\overline{\text{PME}}$ signal, etc.

15.5 Interrupt Sources

15.5.1 IBFI1, IBFI2, IBFI3, and ERRI

The host interface has four interrupt requests for the slave processor (this LSI): IBF1, IBF2, IBF3, and ERRI. IBFI1, IBFI2, and IBFI3 are IDR receive complete interrupts for IDR1, IDR2, and IDR3 and TWR, respectively. The ERRI interrupt indicates the occurrence of a special state such as an LPC reset, LPC shutdown, or transfer cycle abort. An interrupt request is enabled by setting the corresponding enable bit.

Table 15.7 Receive Complete Interrupts and Error Interrupt

Interrupt	Description
IBFI1	When IBFIE1 is set to 1 and IDR1 reception is completed
IBFI2	When IBFIE2 is set to 1 and IDR2 reception is completed
IBFI3	When IBFIE3 is set to 1 and IDR3 reception is completed, or when TWRE and IBFIE3 are set to 1 and reception is completed up to TWR15
ERRI	When ERRIE is set to 1 and one of LRST, SDWN and ABRT is set to 1

15.5.2 SMI, HIRQ1, HIRQ6, HIRQ9, HIRQ10, HIRQ11, and HIRQ12

The host interface can request seven kinds of host interrupt by means of SERIRQ. HIRQ1 and HIRQ12 are used on LPC channel 1 only, while SMI, HIRQ6, HIRQ9, HIRQ10, and HIRQ11 can be requested from LPC channel 2 or 3.

There are two ways of clearing a host interrupt request.

When the IEDIR bit is cleared to 0 in SIRQCR0, host interrupt sources and LPC channels are all linked to the host interrupt request enable bits. When the OBF flag is cleared to 0 by a read of ODR or TWR15 by the host in the corresponding LPC channel, the corresponding host interrupt enable bit is automatically cleared to 0, and the host interrupt request is cleared.

When the IEDIR bit is set to 1 in SIRQCR0, LPC channel 2 and 3 interrupt requests are dependent only upon the host interrupt enable bits. The host interrupt enable bit is not cleared when OBF for channel 2 or 3 is cleared. Therefore, SMIE2, SMIE3A and SMIE3B, IRQ6E2 and IRQ6E3, IRQ9E2 and IRQ9E3, IRQ10E2 and IRQ10E3, and IRQ11E2 and IRQ11E3 lose their respective functional differences. In order to clear a host interrupt request, it is necessary to clear the host interrupt enable bit.

Table 15.8 summarizes the methods of setting and clearing these bits, and figure 15.8 shows the processing flowchart.

Table 15.8 HIRQ Setting and Clearing Conditions

Host Interrupt	Setting Condition	Clearing Condition
HIRQ1 (independent from IEDIR)	Internal CPU writes to ODR1, then reads 0 from bit IRQ1E1 and writes 1	Internal CPU writes 0 to bit IRQ1E1, or host reads ODR1
HIRQ12 (independent from IEDIR)	Internal CPU writes to ODR1, then reads 0 from bit IRQ12E1 and writes 1	Internal CPU writes 0 to bit IRQ12E1, or host reads ODR1
SMI (IEDIR = 0)	Internal CPU <ul style="list-style-type: none"> • writes to ODR2, then reads 0 from bit SMIE2 and writes 1 • writes to ODR3, then reads 0 from bit SMIE3A and writes 1 • writes to TWR15, then reads 0 from bit SMIE3B and writes 1 	Internal CPU <ul style="list-style-type: none"> • writes 0 to bit SMIE2, or host reads ODR2 • writes 0 to bit SMIE3A, or host reads ODR3 • writes 0 to bit SMIE3B, or host reads TWR15
SMI (IEDIR = 1)	Internal CPU <ul style="list-style-type: none"> • reads 0 from bit SMIE2, then writes 1 • reads 0 from bit SMIE3A, then writes 1 • reads 0 from bit SMIE3B, then writes 1 	Internal CPU <ul style="list-style-type: none"> • writes 0 to bit SMIE2 • writes 0 to bit SMIE3A • writes 0 to bit SMIE3B
HIRQi (i = 6, 9, 10, 11) (IEDIR = 0)	Internal CPU <ul style="list-style-type: none"> • writes to ODR2, then reads 0 from bit IRQiE2 and writes 1 • writes to ODR3, then reads 0 from bit IRQiE3 and writes 1 	Internal CPU <ul style="list-style-type: none"> • writes 0 to bit IRQiE2, or host reads ODR2 • CPU writes 0 to bit IRQiE3, or host reads ODR3
HIRQi (i = 6, 9, 10, 11) (IEDIR = 1)	Internal CPU <ul style="list-style-type: none"> • reads 0 from bit IRQiE2, then writes 1 • reads 0 from bit IRQiE3, then writes 1 	Internal CPU <ul style="list-style-type: none"> • writes 0 to bit IRQiE2 • writes 0 to bit IRQiE3

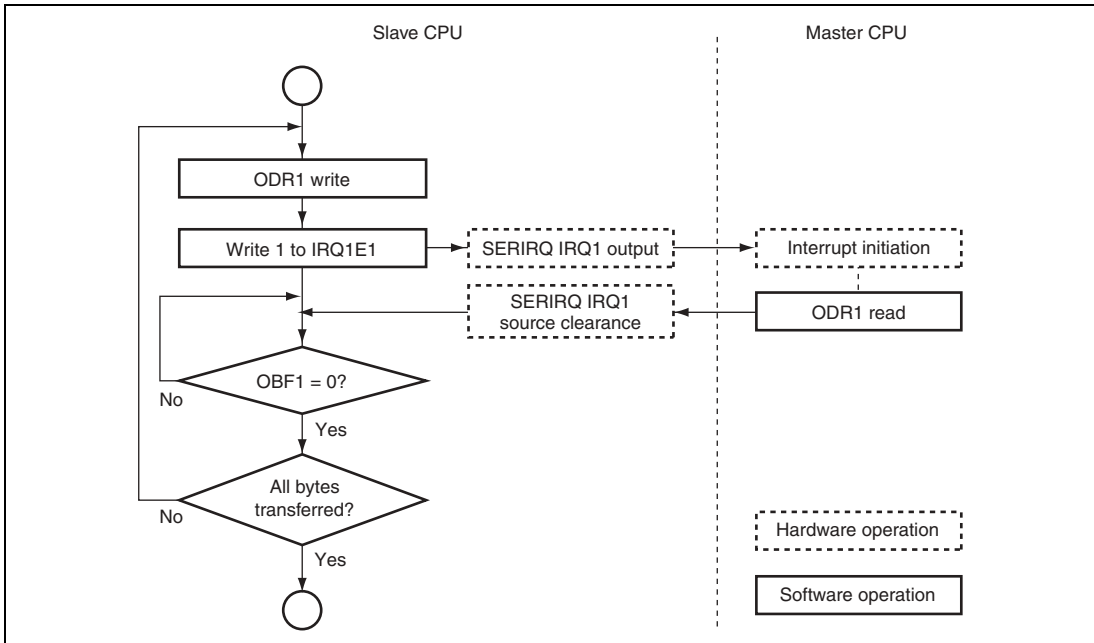

Figure 15.8 HIRQ Flowchart (Example of Channel 1)

15.6 Usage Notes

15.6.1 Module Stop Mode Setting

LPC operation can be enabled or disabled using the module stop control register. The initial setting is for LPC operation to be halted. Register access is enabled by canceling module stop mode. For details, refer to section 20, Power-Down Modes.

15.6.2 Notes on Using Host Interface

The host interface provides buffering of asynchronous data from the host processor and slave processor (this LSI), but an interface protocol that uses the flags in STR must be followed to avoid data contention. For example, if the host and slave processor both try to access IDR or ODR at the same time, the data will be corrupted. To prevent simultaneous accesses, IBF and OBF must be used to allow access only to data for which writing has finished.

Unlike the IDR and ODR registers, the transfer direction is not fixed for the bidirectional data registers (TWR). MWMF and SWMF are provided in STR to handle this situation. After writing to TWR0, MWMF and SWMF must be used to confirm that the write authority for TWR1 to TWR15 has been obtained.

Table 15.9 shows host address examples for LADR3 and registers, IDR3, ODR3, STR3, TWR0MW, TWR0SW, and TWR1 to TWR15 when LADR3 = H'A24F and LADR3 = H'3FD0.

Table 15.9 Host Address Example

Register	Host Address when LADR3 = H'A24F	Host Address when LADR3 = H'3FD0
IDR3	H'A24A and H'A24E	H'3FD0 and H'3FD4
ODR3	H'A24A	H'3FD0
STR3	H'A24E	H'3FD4
TWR0MW	H'A250	H'3FC0
TWR0SW	H'A250	H'3FC0
TWR1	H'A251	H'3FC1
TWR2	H'A252	H'3FC2
TWR3	H'A253	H'3FC3
TWR4	H'A254	H'3FC4
TWR5	H'A255	H'3FC5
TWR6	H'A256	H'3FC6
TWR7	H'A257	H'3FC7
TWR8	H'A258	H'3FC8
TWR9	H'A259	H'3FC9
TWR10	H'A25A	H'3FCA
TWR11	H'A25B	H'3FCB
TWR12	H'A25C	H'3FCC
TWR13	H'A25D	H'3FCD
TWR14	H'A25E	H'3FCE
TWR15	H'A25F	H'3FCF

Section 16 A/D Converter

This LSI includes a successive-approximation-type 10-bit A/D converter that allows up to six analog input channels to be selected. A/D conversion for digital input is effective as a comparator in multiple input testing.

16.1 Features

- 10-bit resolution
- Input channels: six analog input channels
- Analog conversion voltage range can be specified using the reference power supply voltage pin (AVref) as an analog reference voltage.
- Conversion time: 13.4 μ s per channel (at 10 MHz operation)
- Two kinds of operating modes
 - Single mode: Single-channel A/D conversion
 - Scan mode: Continuous A/D conversion on 1 to 4 channels
- Four data registers
 - Conversion results are held in a 16-bit data register for each channel
- Sample and hold function
- Three kinds of conversion start
 - Software, 8-bit timer (TMR) conversion start trigger, or external trigger signal.
- Interrupt request
 - A/D conversion end interrupt (ADI) request can be generated

A block diagram of the A/D converter is shown in figure 16.1.

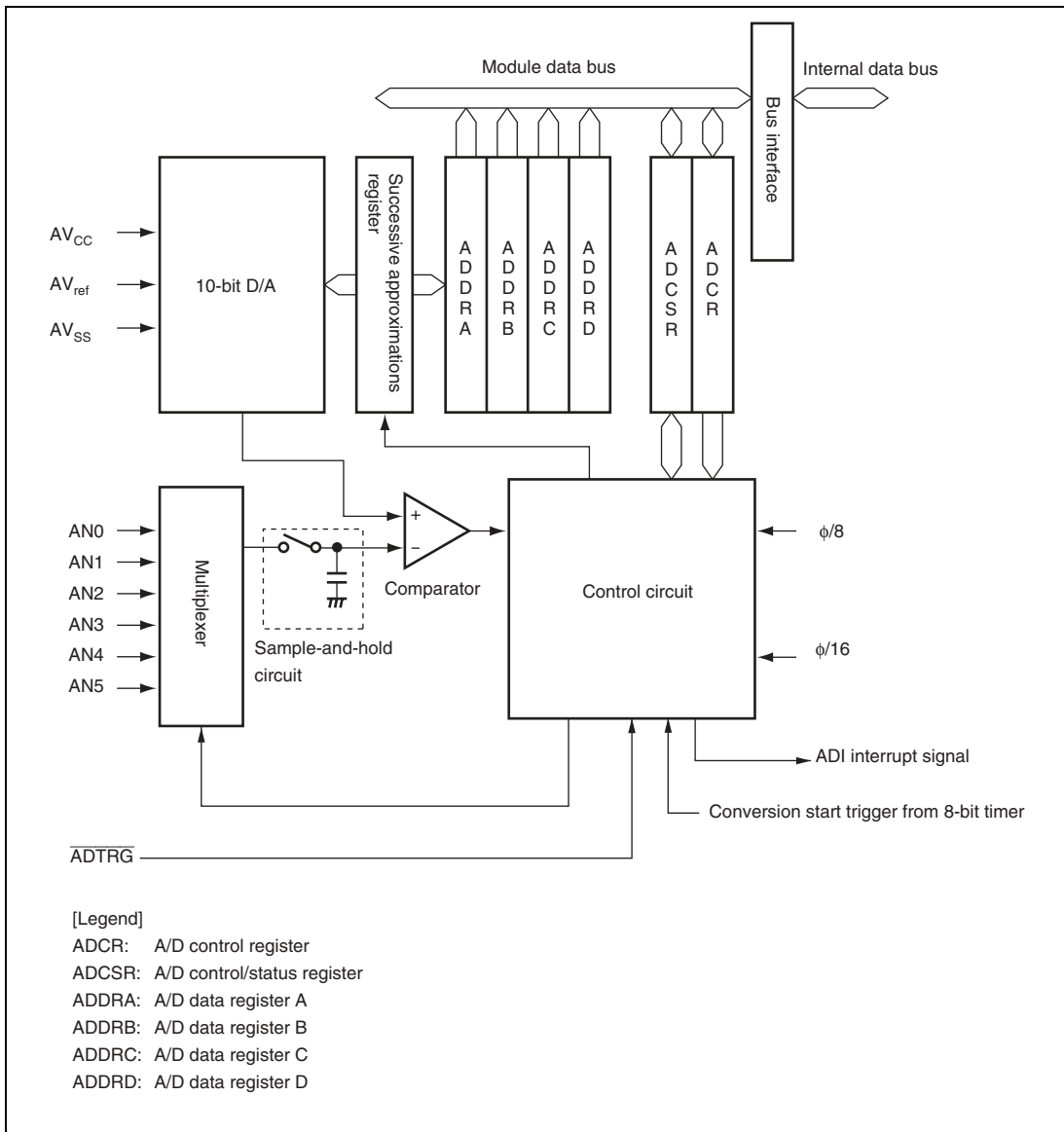

Figure 16.1 Block Diagram of A/D Converter

16.2 Input/Output Pins

Table 16.1 summarizes the pins used by the A/D converter. The 6 analog input pins are divided into two groups consisting of four channels and two channels. Analog input pins 0 to 3 (AN0 to AN3) comprising group 0 and analog input pins 4 and 5 (AN4 and AN5) comprising group 1. The AV_{cc} and AV_{ss} pins are the power supply pins for the analog block in the A/D converter.

Table 16.1 Pin Configuration

Pin Name	Symbol	I/O	Function
Analog power supply pin	AV _{cc}	Input	Analog block power supply and reference voltage
Analog ground pin	AV _{ss}	Input	Analog block ground and reference voltage
Reference power supply pin	AVref	Input	Reference voltage for A/D conversion
Analog input pin 0	AN0	Input	Group 0 analog input pins
Analog input pin 1	AN1	Input	
Analog input pin 2	AN2	Input	
Analog input pin 3	AN3	Input	
Analog input pin 4	AN4	Input	Group 1 analog input pins
Analog input pin 5	AN5	Input	
A/D external trigger input pin	$\overline{\text{ADTRG}}$	Input	External trigger input pin for starting A/D conversion

16.3 Register Descriptions

The A/D converter has the following registers.

- A/D data register A (ADDRA)
- A/D data register B (ADDRB)
- A/D data register C (ADDRC)
- A/D data register D (ADDRD)
- A/D control/status register (ADCSR)
- A/D control register (ADCR)

16.3.1 A/D Data Registers A to D (ADDRA to ADDRD)

There are four 16-bit read-only ADDR registers, ADDRA to ADDRD, used to store the results of A/D conversion. The ADDR registers, which store a conversion result for each channel, are shown in table 16.2.

The converted 10-bit data is stored to bits 15 to 6. The lower 6-bit data is always read as 0.

The data bus between the CPU and the A/D converter is 8-bit width. The upper byte can be read directly from the CPU, but the lower byte should be read via a temporary register. The temporary register contents are transferred from the ADDR when the upper byte data is read. When reading the ADDR, read the upper byte before lower byte or in word units.

Table 16.2 Analog Input Channels and Corresponding ADDR Registers

Analog Input Channel		A/D Data Register to Store A/D Conversion Results
Group 0	Group 1	
AN0	AN4	ADDRA
An1	AN5	ADDRB
AN2	—	ADDRC
AN3	—	ADDRD

16.3.2 A/D Control/Status Register (ADCSR)

ADCSR controls A/D conversion operations.

Bit	Bit Name	Initial Value	R/W	Description
7	ADF	0	R/(W)*	<p>A/D End Flag</p> <p>A status flag that indicates the end of A/D conversion.</p> <p>[Setting conditions]</p> <ul style="list-style-type: none">• When A/D conversion ends in single mode• When A/D conversion ends on all channels specified in scan mode <p>[Clearing conditions]</p> <ul style="list-style-type: none">• When 0 is written after reading ADF = 1
6	ADIE	0	R/W	<p>A/D Interrupt Enable</p> <p>Enables ADI interrupt by ADF when this bit is set to 1</p>
5	ADST	0	R/W	<p>A/D Start</p> <p>Setting this bit to 1 starts A/D conversion. Clearing this bit to 0 stops A/D conversion. In single mode, this bit is cleared to 0 automatically when conversion on the specified channel ends. In scan mode, conversion continues sequentially on the specified channels until this bit is cleared to 0 by software, a reset, or a transition to standby mode or module stop mode.</p>
4	SCAN	0	R/W	<p>Scan Mode</p> <p>Selects the A/D conversion operating mode. The setting of this bit must be made when conversion is halted (ADST = 0).</p> <p>0: Single mode</p> <p>1: Scan mode</p>
3	CKS	0	R/W	<p>Clock Select</p> <p>Sets A/D conversion time. The input channel setting must be made when conversion is halted (ADST = 0).</p> <p>0: Conversion time is 266 states (max)</p> <p>1: Conversion time is 134 states (max)</p> <p>Switch conversion time while ADST is 0.</p>

Bit	Bit Name	Initial Value	R/W	Description																		
2	CH2	0	R/W	Channel Select 2 to 0																		
1	CH1	0	R/W	Select analog input channels. The input channel setting must be made when conversion is halted (ADST = 0).																		
0	CH0	0	R/W	<table border="0"> <tr> <td>When SCAN = 0:</td> <td>When SCAN = 1:</td> </tr> <tr> <td>000: AN0</td> <td>000: AN0</td> </tr> <tr> <td>001: AN1</td> <td>001: AN0 and AN1</td> </tr> <tr> <td>010: AN2</td> <td>010: AN0 to AN2</td> </tr> <tr> <td>011: AN3</td> <td>011: AN0 to AN3</td> </tr> <tr> <td>100: AN4</td> <td>100: AN4</td> </tr> <tr> <td>101: AN5</td> <td>101: AN4 and AN5</td> </tr> <tr> <td>110: Setting prohibited</td> <td>110: Setting prohibited</td> </tr> <tr> <td>111: Setting prohibited</td> <td>111: Setting prohibited</td> </tr> </table>	When SCAN = 0:	When SCAN = 1:	000: AN0	000: AN0	001: AN1	001: AN0 and AN1	010: AN2	010: AN0 to AN2	011: AN3	011: AN0 to AN3	100: AN4	100: AN4	101: AN5	101: AN4 and AN5	110: Setting prohibited	110: Setting prohibited	111: Setting prohibited	111: Setting prohibited
When SCAN = 0:	When SCAN = 1:																					
000: AN0	000: AN0																					
001: AN1	001: AN0 and AN1																					
010: AN2	010: AN0 to AN2																					
011: AN3	011: AN0 to AN3																					
100: AN4	100: AN4																					
101: AN5	101: AN4 and AN5																					
110: Setting prohibited	110: Setting prohibited																					
111: Setting prohibited	111: Setting prohibited																					

Note: * Only 0 can be written for clearing the flag.

16.3.3 A/D Control Register (ADCR)

ADCR enables A/D conversion started by an external trigger signal.

Bit	Bit Name	Initial Value	R/W	Description				
7	TRGS1	0	R/W	Timer Trigger Select 1 and 0				
6	TRGS0	0	R/W	<p>Enable the start of A/D conversion by a trigger signal. Only set bits TRGS1 and TRGS0 when conversion is halted (ADST = 0).</p> <table border="0"> <tr> <td>00: A/D conversion start by external trigger is disabled</td> </tr> <tr> <td>01: A/D conversion start by external trigger is disabled</td> </tr> <tr> <td>10: A/D conversion start by conversion trigger from TMR is enabled</td> </tr> <tr> <td>11: A/D conversion start by $\overline{\text{ADTRG}}$ pin is enabled</td> </tr> </table>	00: A/D conversion start by external trigger is disabled	01: A/D conversion start by external trigger is disabled	10: A/D conversion start by conversion trigger from TMR is enabled	11: A/D conversion start by $\overline{\text{ADTRG}}$ pin is enabled
00: A/D conversion start by external trigger is disabled								
01: A/D conversion start by external trigger is disabled								
10: A/D conversion start by conversion trigger from TMR is enabled								
11: A/D conversion start by $\overline{\text{ADTRG}}$ pin is enabled								
5 to 0	—	All 1	R	<p>Reserved</p> <p>These bits are always read as 1 and cannot be modified.</p>				

16.4 Operation

The A/D converter operates by successive approximation with 10-bit resolution. It has two operating modes: single mode and scan mode. When changing the operating mode or analog input channel, to prevent incorrect operation, first clear the ADST bit to 0 in ADCSR to halt A/D conversion. The ADST bit can be set at the same time as the operating mode or analog input channel is changed.

16.4.1 Single Mode

In single mode, A/D conversion is to be performed only once on the specified single channel. Operations are as follows.

1. A/D conversion on the specified channel is started when the ADST bit in ADCSR is set to 1, by software or an external trigger input.
2. When A/D conversion is completed, the result is transferred to the A/D data register corresponding to the channel.
3. On completion of A/D conversion, the ADF bit in ADCSR is set to 1. If the ADIE bit is set to 1 at this time, an ADI interrupt request is generated.
4. The ADST bit remains set to 1 during A/D conversion. When conversion ends, the ADST bit is automatically cleared to 0, and the A/D converter enters wait state.

16.4.2 Scan Mode

Scan mode is useful for monitoring analog inputs in a group of one or more channels. When the ADST bit is set to 1 by software, or by timer or external trigger input, A/D conversion starts on the first channel in the group (AN0 when CH2 = 0; AN4 when CH2 = 1).

When two or more channels are selected, after conversion of the first channel ends, conversion of the second channel (AN1 or AN5) starts immediately. A/D conversion continues cyclically on the selected channels until the ADST bit is cleared to 0. The conversion results are transferred for storage into the ADDR registers corresponding to the channels.

Typical operations when three channels (AN0 to AN2) are selected in scan mode are described below.

Figure 16.2 shows the operation timing.

1. Scan mode is selected (SCAN = 1), scan group 0 is selected (CH2 = 0), analog input channels AN0 to AN2 are selected (CH1 = 1, CH0 = 0), and A/D conversion is started (ADST = 1).
2. When A/D conversion of the first channel (AN0) is completed, the result is transferred to ADDRA. Next, conversion of the second channel (AN1) starts automatically.
3. Conversion proceeds in the same way through the third channel (AN2).
4. When conversion of all the selected channels (AN0 to AN2) is completed, the ADF flag is set to 1 and conversion of the first channel (AN0) starts again. If the ADIE bit is set to 1 at this time, an ADI interrupt is requested after A/D conversion ends.
5. Steps 2 to 4 are repeated as long as the ADST bit remains set to 1. When the ADST bit is cleared to 0, A/D conversion stops. After that, if the ADST bit is set to 1, A/D conversion starts again from the first channel (AN0).

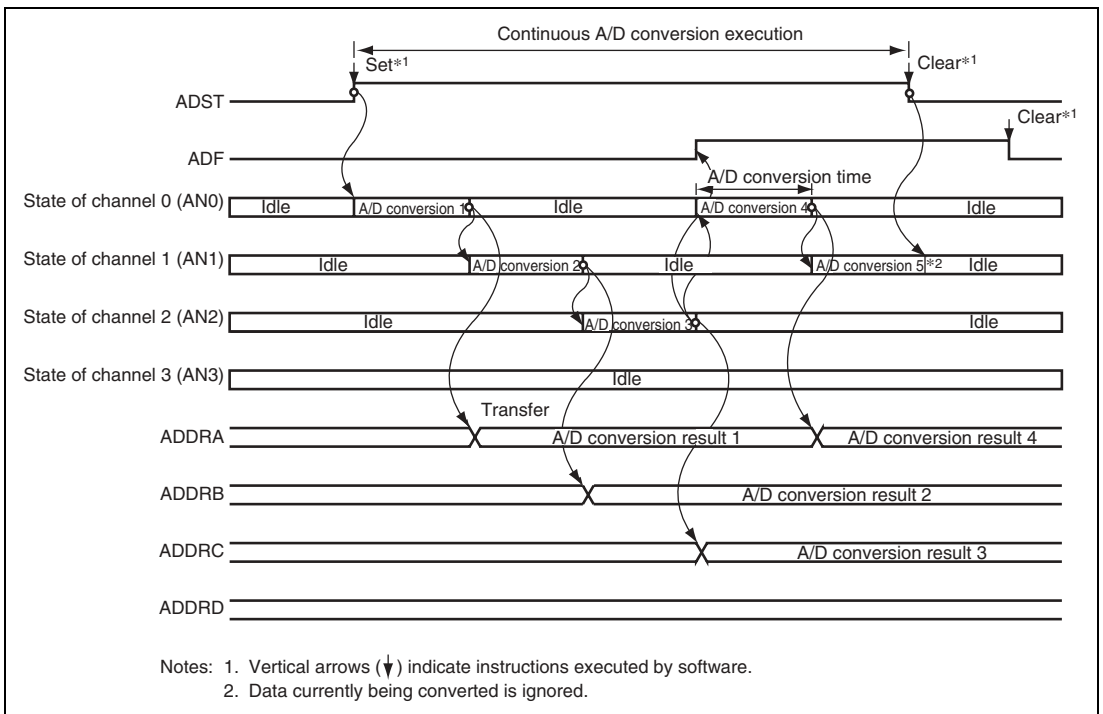

**Figure 16.2 Example of A/D Converter Operation
(Scan Mode, Channels AN0 to AN2 Selected)**

16.4.3 Input Sampling and A/D Conversion Time

The A/D converter has a built-in sample-and-hold circuit. The A/D converter samples the analog input when the A/D conversion start delay time (t_D) passes after the ADST bit in ADCSR is set to 1, then starts A/D conversion. Figure 16.3 shows the A/D conversion timing. Table 16.3 indicates the A/D conversion time.

As indicated in figure 16.3, the A/D conversion time (t_{CONV}) includes t_D and the input sampling time (t_{SPL}). The length of t_D varies depending on the timing of the write access to ADCSR. The total conversion time therefore varies within the ranges indicated in table 16.3.

In scan mode, the values given in table 16.3 apply to the first conversion time. In the second and subsequent conversions, the conversion time is 256 state (fixed) when CKS = 0 and 128 states (fixed) when CKS = 1.

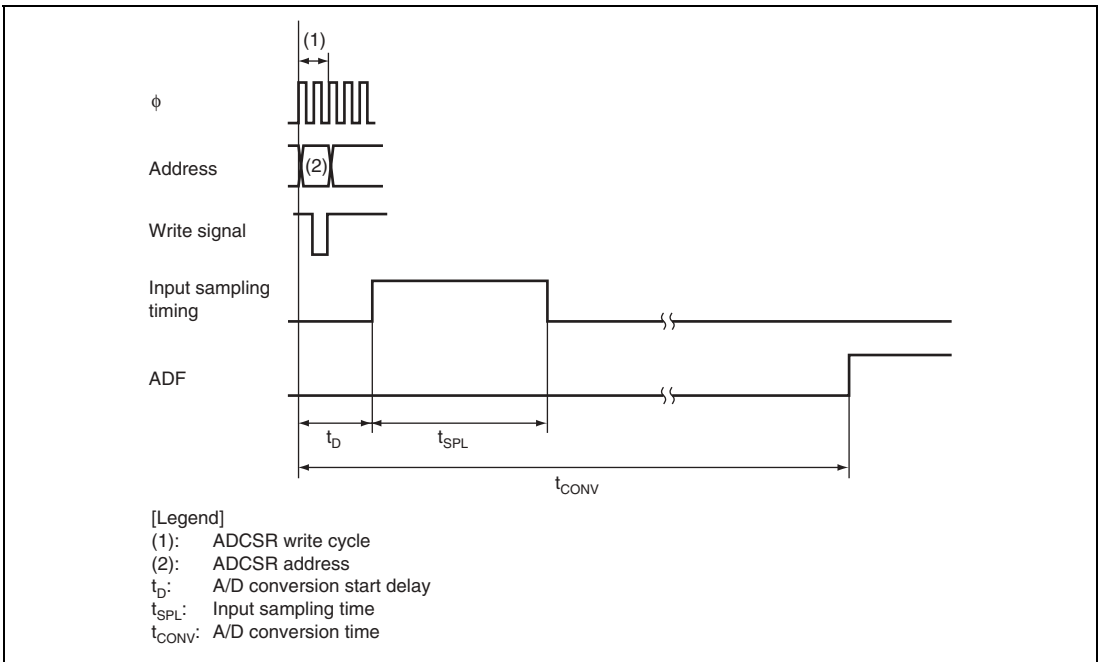

Figure 16.3 A/D Conversion Timing

Table 16.3 A/D Conversion Time (Single Mode)

Item	Symbol	CKS = 0			CKS = 1		
		Min.	Typ.	Max.	Min.	Typ.	Max.
A/D conversion start delay time	t_D	10	—	17	6	—	9
Input sampling time	t_{SPL}	—	63	—	—	31	—
A/D conversion time	t_{CONV}	259	—	266	131	—	134

Note: * Values in the table indicate the number of states.

16.4.4 External Trigger Input Timing

A/D conversion can be externally triggered. When the TRGS1 and TRGS0 bits are set to B'11 in ADCR, external trigger input is enabled at the \overline{ADTRG} pin. A falling edge at the \overline{ADTRG} pin sets the ADST bit to 1 in ADCSR, starting A/D conversion. Other operations, in both single and scan modes, are the same as when the ADST bit has been set to 1 by software. Figure 16.4 shows the timing.

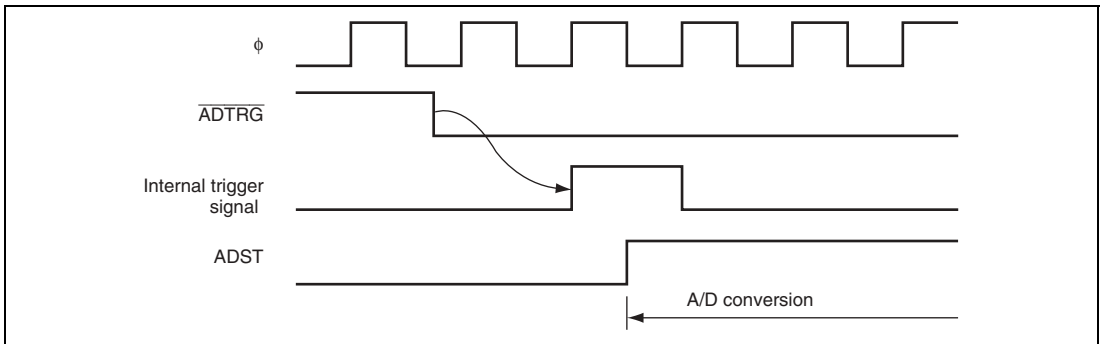

Figure 16.4 External Trigger Input Timing

16.5 Interrupt Sources

The A/D converter generates an A/D conversion end interrupt (ADI) at the end of A/D conversion. Setting the ADIE bit to 1 enables ADI interrupt requests while the ADF bit in ADCSR is set to 1 after A/D conversion is completed.

16.6 A/D Conversion Accuracy Definitions

This LSI's A/D conversion accuracy definitions are given below.

- Resolution
The number of A/D converter digital output codes
- Quantization error
The deviation inherent in the A/D converter, given by 1/2 LSB (see figure 16.5).
- Offset error
The deviation of the analog input voltage value from the ideal A/D conversion characteristic when the digital output changes from the minimum voltage value B'000000000 (H'000) to B'000000001 (H'001) (see figure 16.6).
- Full-scale error
The deviation of the analog input voltage value from the ideal A/D conversion characteristic when the digital output changes from B'111111110 (H'3FE) to B'111111111 (H'3FF) (see figure 16.6).
- Nonlinearity error
The error with respect to the ideal A/D conversion characteristics between the zero voltage and the full-scale voltage. Does not include the offset error, full-scale error, or quantization error (see figure 16.6).
- Absolute accuracy
The deviation between the digital value and the analog input value. Includes the offset error, full-scale error, quantization error, and nonlinearity error.

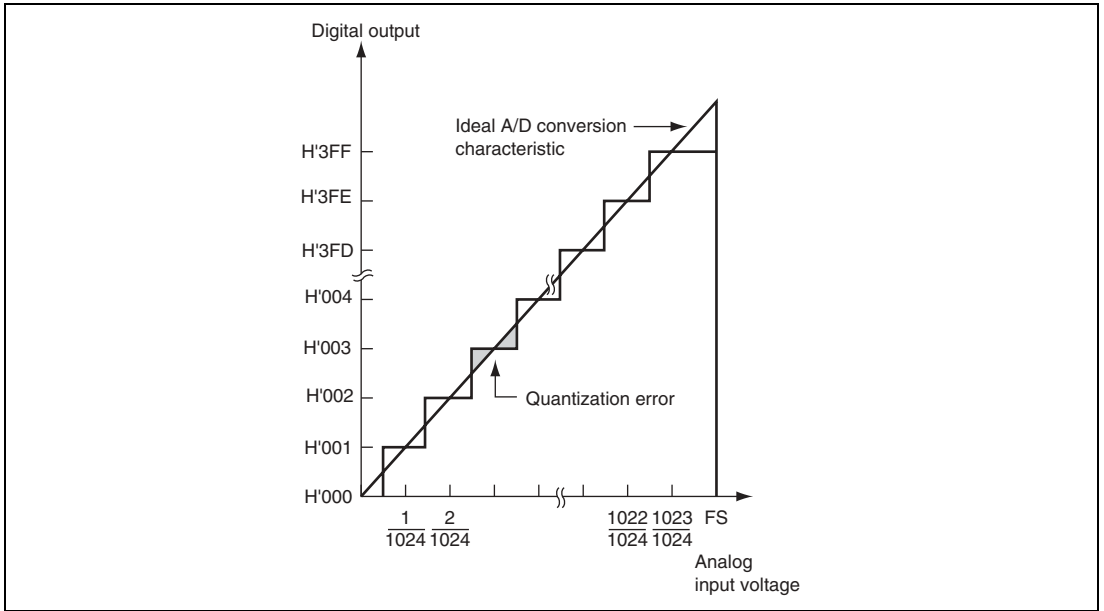

Figure 16.5 A/D Conversion Accuracy Definitions

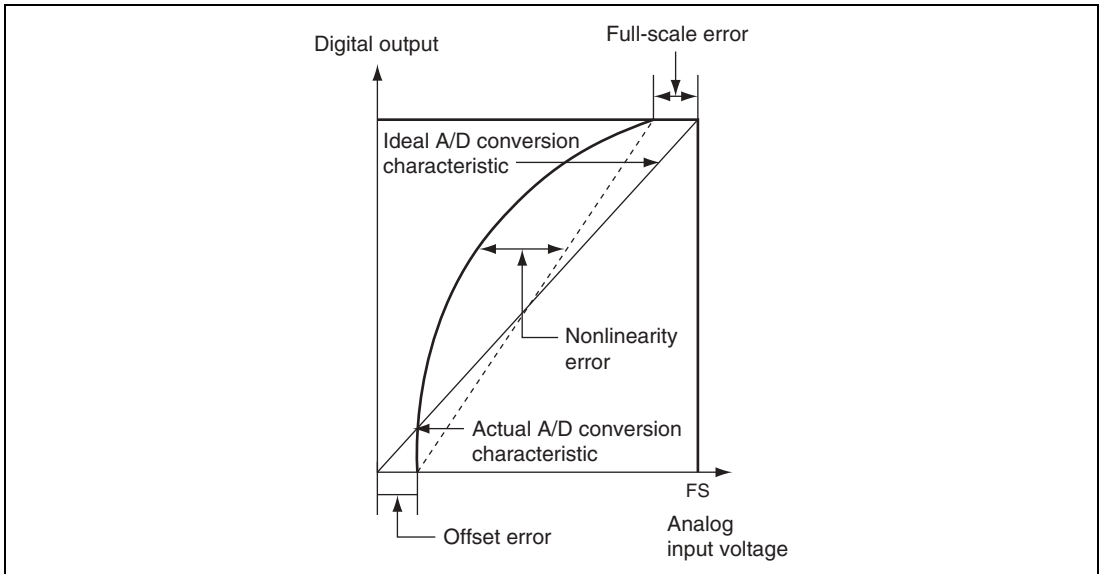

Figure 16.6 A/D Conversion Accuracy Definitions

16.7 Usage Notes

16.7.1 Permissible Signal Source Impedance

This LSI's analog input (3-V version) is designed so that the conversion accuracy is guaranteed for an input signal for which the signal source impedance is $5\text{ k}\Omega$ or less. This specification is provided to enable the A/D converter's sample-and-hold circuit input capacitance to be charged within the sampling time; if the sensor output impedance exceeds $5\text{ k}\Omega$, charging may be insufficient and it may not be possible to guarantee the A/D conversion accuracy. However, if a large capacitance is provided externally in single mode, the input load will essentially comprise only the internal input resistance of $10\text{ k}\Omega$, and the signal source impedance is ignored. However, since a low-pass filter effect is obtained in this case, it may not be possible to follow an analog signal with a large differential coefficient (e.g., voltage fluctuation ratio of $5\text{ mV}/\mu\text{s}$ or greater) (see figure 16.7). When converting a high-speed analog signal or converting in scan mode, a low-impedance buffer should be inserted.

16.7.2 Influences on Absolute Accuracy

Adding capacitance results in coupling with ground, and therefore noise in ground may adversely affect the absolute accuracy. Be sure to make the connection to an electrically stable ground such as AVSS.

Care is also required to insure that filter circuits do not communicate with digital signals on the mounting board, so acting as antennas.

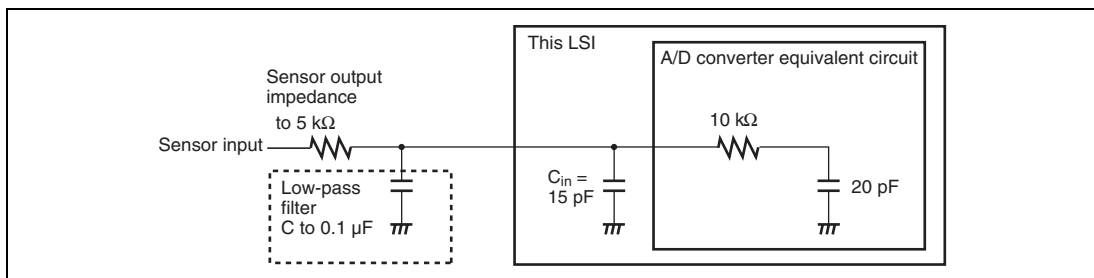

Figure 16.7 Example of Analog Input Circuit

16.7.3 Setting Range of Analog Power Supply and Other Pins

If conditions shown below are not met, the reliability of this LSI may be adversely affected.

- Analog input voltage range
The voltage applied to analog input pin ANn during A/D conversion should be in the range $AV_{SS} \leq ANn \leq AV_{ref}$ ($n = 0$ to 5).
- Relation between AV_{CC} , AV_{SS} and V_{CC} , V_{SS}
For the relationship between AV_{CC} , AV_{SS} and V_{CC} , V_{SS} , set $AV_{SS} = V_{SS}$. If the A/D converter is not used, the AV_{CC} and AV_{SS} pins must on no account be left open.
- AV_{ref} pin reference voltage specification range
The reference voltage of the AV_{ref} pin should be in the range $AV_{ref} \leq AV_{CC}$.

16.7.4 Notes on Board Design

In board design, digital circuitry and analog circuitry should be as mutually isolated as possible, and layout in which digital circuit signal lines and analog circuit signal lines cross or are in close proximity should be avoided as far as possible. Failure to do so may result in incorrect operation of the analog circuitry due to inductance, adversely affecting A/D conversion values. Also, digital circuitry must be isolated from the analog input signals ($AN0$ to $AN5$), analog reference voltage (AV_{ref}), and analog power supply (AV_{CC}) by the analog ground (AV_{SS}). Also, the analog ground (AV_{SS}) should be connected at one point to a stable digital ground (V_{SS}) on the board.

16.7.5 Notes on Noise Countermeasures

A protection circuit connected to prevent damage due to an abnormal voltage such as an excessive surge at the analog input pins ($AN0$ to $AN5$) and analog reference voltage (AV_{ref}) should be connected between AV_{CC} and AV_{SS} as shown in figure 16.8. Also, the bypass capacitors connected to AV_{CC} and AV_{ref} , and the filter capacitor connected to $AN0$ to $AN5$, must be connected to AV_{SS} .

If a filter capacitor is connected, the input currents at the analog input pins ($AN0$ to $AN5$) are averaged, and so an error may arise. Also, when A/D conversion is performed frequently, as in scan mode, if the current charged and discharged by the capacitance of the sample-and-hold circuit in the A/D converter exceeds the current input via the input impedance (R_{in}), an error will arise in the analog input pin voltage. Careful consideration is therefore required when deciding the circuit constants.

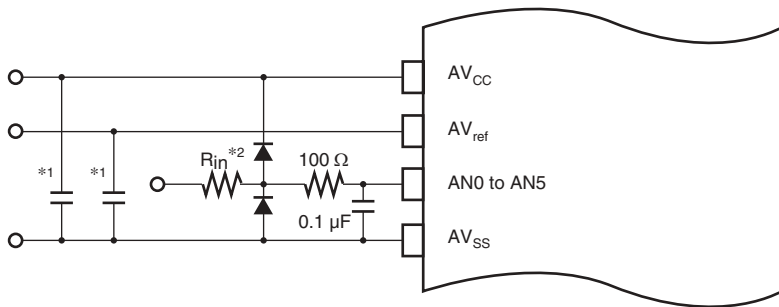

Notes: Values are reference values.

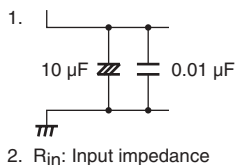
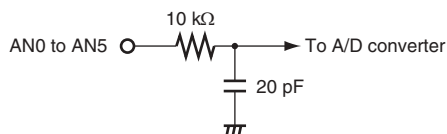

Figure 16.8 Example of Analog Input Protection Circuit



Note: * Values are reference values.

Figure 16.9 Equivalent Circuit of Analog Input Pin

16.7.6 Module Stop Mode Setting

A/D converter operation can be enabled or disabled using the module stop control register. The initial setting is for A/D converter operation to be halted. Register access is enabled by canceling module stop mode. For details, refer to section 20, Power-Down Modes.

Section 17 RAM

This LSI has an on-chip high-speed static RAM. The RAM is connected to the CPU by a 16-bit data bus, enabling one-state access by the CPU to both byte data and word data.

The on-chip RAM can be enabled or disabled by means of the RAME bit in the system control register (SYSCR). For details on SYSCR, refer to section 3.2.2, System Control Register (SYSCR).

	Product Classification	RAM Capacitance	RAM Address
Flash memory version	H8S/2111B-B	2 Kbytes	H'E880 to H'FFFF, H'FF00 to H'FF7F
	H8S/2111B-C	3 Kbytes	H'E480 to H'FFFF, H'FF00 to H'FF7F

Section 18 ROM

This LSI has an on-chip ROM (flash memory). The features of the flash memory are summarized below.

A block diagram of the flash memory is shown in figure 18.1.

18.1 Features

- Size

Product Classification	ROM Capacitance	ROM Address
H8S/2111B	64 Kbytes	H'000000 to H'00FFFF (mode 2) H'0000 to H'DFFF (mode 3)

- Programming/erase methods

The flash memory is programmed 128 bytes at a time. Erase is performed in single-block units. The flash memory is configured as follows:

— 8 Kbytes × 2 blocks, 16 Kbytes × 1 block, 28 Kbytes × 1 block, and 1 Kbyte × 4 blocks

To erase the entire flash memory, each block must be erased in turn.

- Programming/erase time

It takes 10 ms (typ.) to program the flash memory 128 bytes at a time; 80 μs (typ.) per 1 byte. Erasing one block takes 100 ms (typ.).

- Reprogramming capability

The flash memory can be reprogrammed up to 100 times.

- Two flash memory on-board programming modes

— Boot mode

— User program mode

On-board programming/erasing can be done in boot mode in which the boot program built into the chip is started for erase or programming of the entire flash memory. In user program mode, individual blocks can be erased or programmed.

- Automatic bit rate adjustment

With data transfer in boot mode, this LSI's bit rate can be automatically adjusted to match the transfer bit rate of the host.

- Programming/erasing protection

Sets protection against flash memory programming/erasing via hardware, software, or error protection.

- Programmer mode

In addition to on-board programming mode, programmer mode is supported to program or erase the flash memory using a PROM programmer.

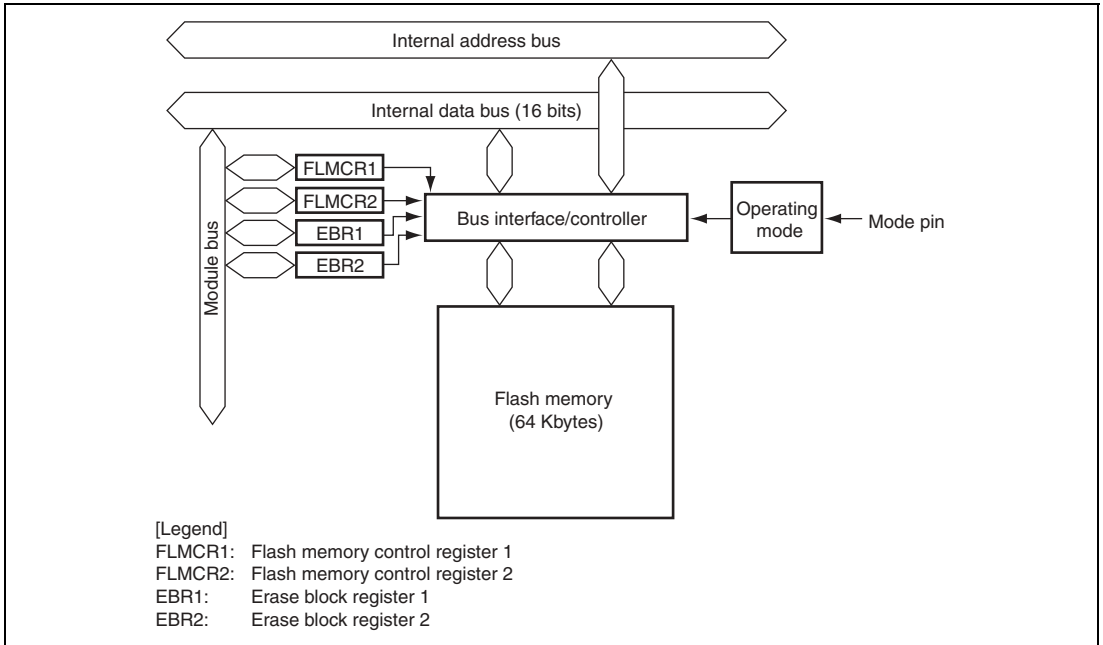

Figure 18.1 Block Diagram of Flash Memory

18.2 Mode Transitions

When the mode pins are set in the reset state and a reset-start is executed, this LSI enters an operating mode as shown in figure 18.2. In user mode, flash memory can be read but not programmed or erased. The boot, user program, and programmer modes are provided as modes to write and erase the flash memory.

The differences between boot mode and user program mode are shown in table 18.1. Figure 18.3 shows the boot mode and figure 18.4 shows the user program mode.

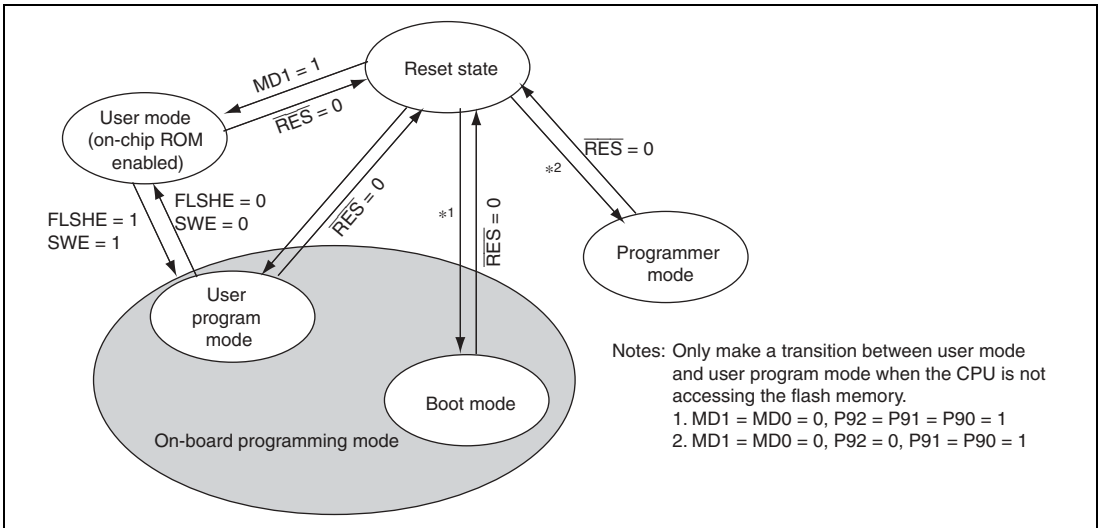

Figure 18.2 Flash Memory State Transitions

Table 18.1 Differences between Boot Mode and User Program Mode

	Boot Mode	User Program Mode
Total erase	Yes	Yes
Block erase	No	Yes
Programming control program*	Program/program-verify	Program/program-verify Erase/erase-verify

Note: * Should be provided by the user, in accordance with the recommended algorithm.

1. Initial state
The flash memory is erased at shipment. The following describes how to write over an old-version application program or data in the flash memory. The user should prepare the programming control program and new application program beforehand in the host.

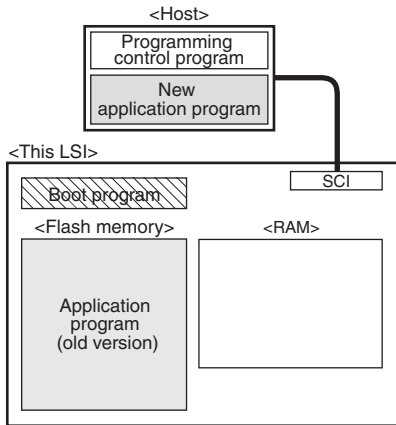

2. SCI communication check
When boot mode is entered, the boot program in this LSI (originally incorporated in the chip) is started and SCI communication is checked. Then the boot program required for flash memory erasing is automatically transferred to the RAM boot program area.

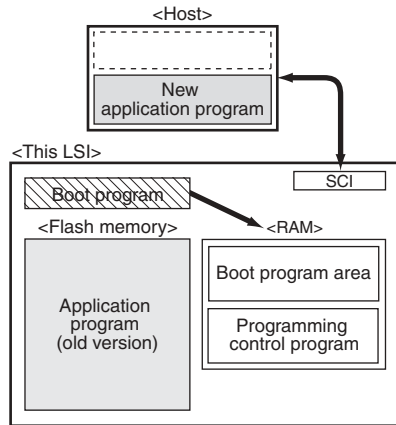

3. Flash memory initialization
The erase program in the boot program area (in RAM) is executed, and the flash memory is initialized (to H'FF). In boot mode, total flash memory erasure is performed, without regard to blocks.

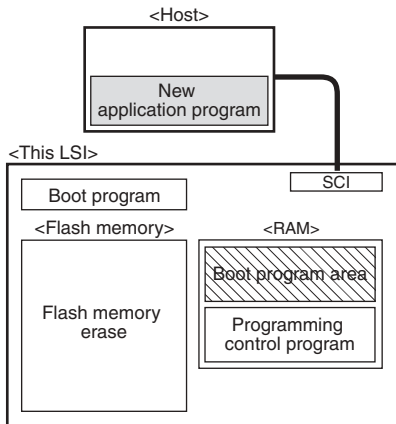

4. Writing new application program
The programming control program transferred from the host to RAM via SCI communication is executed, and the new application program in the host is written into the flash memory.

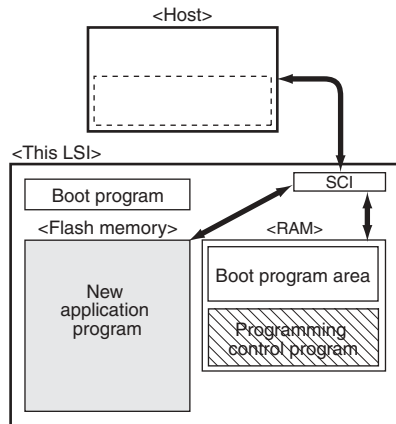

Program execution state

Figure 18.3 Boot Mode

- Initial state
 - The program that will transfer the programming/erase control program from flash memory to on-chip RAM should be written into the flash memory by the user beforehand.
 - The programming/erase control program should be prepared in the host or in the flash memory.

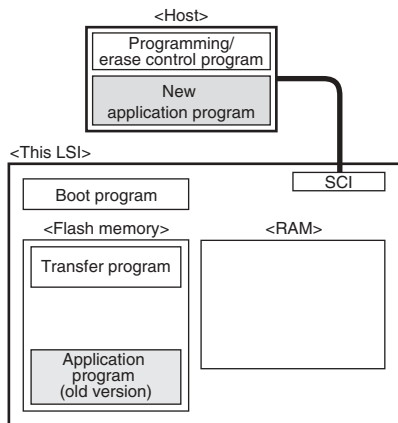

- Programming/erase control program transfer

The transfer program in the flash memory is executed and the programming/erase control program is transferred to RAM.

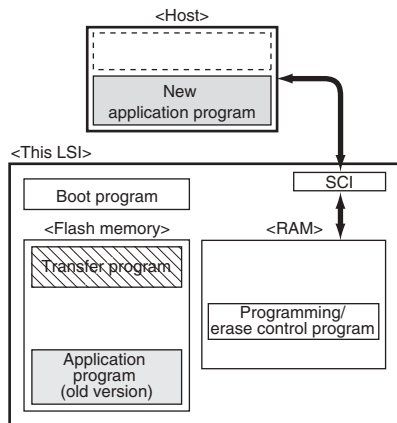

- Flash memory initialization

The programming/erase program in RAM is executed, and the flash memory is initialized (to H'FF). Erasing can be performed in block units, but not in byte units.

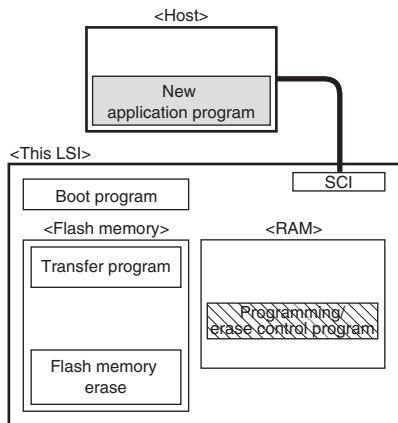

- Writing new application program

Next, the new application program in the host is written into the erased flash memory blocks. Do not write to unerased blocks.

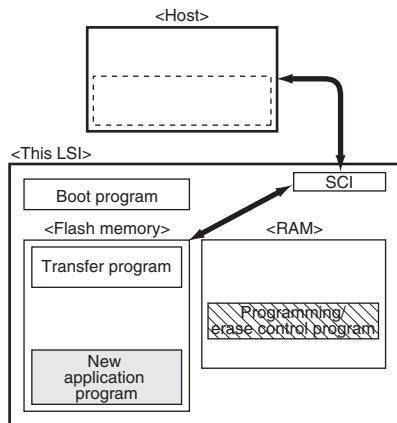

 Program execution state

Figure 18.4 User Program Mode (Example)

18.3 Block Configuration

Figure 18.5 shows the block configuration of flash memory. The thick lines indicate erasing units, the narrow lines indicate programming units, and the values are addresses. The flash memory is divided into 8 Kbytes (2 blocks), 16 Kbytes (1 block), 28 Kbytes (1 block), and 1 Kbyte (4 blocks). Erasing is performed in these divided units. Programming is performed in 128-byte units starting from an address whose lower bits are H'00 or H'80.

EB0 Erase unit: 1 Kbyte	H'000000	H'000001	H'000002	← Programming unit: 128 bytes →	H'00007F
	H'000380	H'000381	H'000382	-----	H'0003FF
EB1 Erase unit: 1 Kbyte	H'000400	H'000401	H'000402	← Programming unit: 128 bytes →	H'00047F
	H'000780	H'000781	H'000782	-----	H'0007FF
EB2 Erase unit: 1 Kbyte	H'000800	H'000801	H'000802	← Programming unit: 128 bytes →	H'00087F
	H'000B80	H'000B81	H'000B82	-----	H'000BFF
EB3 Erase unit: 1 Kbyte	H'000C00	H'000C01	H'000C02	← Programming unit: 128 bytes →	H'000C7F
	H'000F80	H'000F81	H'000F82	-----	H'000FFF
EB4 Erase unit: 28 Kbytes	H'001000	H'001001	H'001002	← Programming unit: 128 bytes →	H'00107F
	H'007F80	H'007F81	H'007F82	-----	H'007FFF
EB5 Erase unit: 16 Kbytes	H'008000	H'008001	H'008002	← Programming unit: 128 bytes →	H'00807F
	H'00BF80	H'00BF81	H'00BF82	-----	H'00BFFF
EB6 Erase unit: 8 Kbytes	H'00C000	H'00C001	H'00C002	← Programming unit: 128 bytes →	H'00C07F
	H'00DF80	H'00DF81	H'00DF82	-----	H'00DFFF
EB7 Erase unit: 8 Kbytes	H'00E000	H'00E001	H'00E002	← Programming unit: 128 bytes →	H'00E07F
	H'00FF80	H'00FF81	H'00FF82	-----	H'00FFFF

Figure 18.5 Flash Memory Block Configuration

18.4 Input/Output Pins

The flash memory is controlled by means of the pins shown in table 18.2.

Table 18.2 Pin Configuration

Pin Name	I/O	Function
RES	Input	Reset
MD1	Input	Sets this LSI's operating mode
MD0	Input	Sets this LSI's operating mode
P92	Input	Sets this LSI's operating mode
P91	Input	Sets this LSI's operating mode
P90	Input	Sets this LSI's operating mode
TxD1	Output	Serial transmit data output
RxD1	Input	Serial receive data input

18.5 Register Descriptions

The flash memory has the following registers. To access FLMCR1, FLMCR2, EBR1, or EBR2, the FLSHE bit in the serial/timer control register (STCR) should be set to 1. For details on the serial/timer control register, refer to section 3.2.3, Serial Timer Control Register (STCR).

- Flash memory control register 1 (FLMCR1)
- Flash memory control register 2 (FLMCR2)
- Erase block register 1 (EBR1)
- Erase block register 2 (EBR2)

18.5.1 Flash Memory Control Register 1 (FLMCR1)

FLMCR1, used together with FLMCR2, makes the flash memory transit to program mode, program-verify mode, erase mode, or erase-verify mode. For details on register setting, refer to section 18.8, Flash Memory Programming/Erasing. FLMCR1 is initialized to H'80 by a reset, or in hardware standby mode, software standby mode, sub-active mode, sub-sleep mode, or watch mode.

Bit	Bit Name	Initial Value	R/W	Description
7	FWE	1	R	Flash Write Enable Controls programming/erasing of on-chip flash memory. This bit is always read as 0, and cannot be modified.
6	SWE	0	R/W	Software Write Enable When this bit is set to 1, flash memory programming/erasing is enabled. When this bit is cleared to 0, the EV, PV, E, and P bits in this register, the ESU and PSU bits in FLMCR2, and all EBR1 and EBR2 bits cannot be set to 1. Do not clear these bits and SWE to 0 simultaneously.
5	—	0	R	Reserved
4	—	0	R	These bits are always read as 0 and cannot be modified.
3	EV	0	R/W	Erase-Verify When this bit is set to 1 while SWE = 1, the flash memory transits to erase-verify mode. When it is cleared to 0, erase-verify mode is cancelled.
2	PV	0	R/W	Program-Verify When this bit is set to 1 while SWE = 1, the flash memory transits to program-verify mode. When it is cleared to 0, program-verify mode is cancelled.
1	E	0	R/W	Erase When this bit is set to 1 while SWE = 1 and ESU = 1, the flash memory transits to erase mode. When it is cleared to 0, erase mode is cancelled.
0	P	0	R/W	Program When this bit is set to 1 while SWE = 1 and PSU = 1, the flash memory transits to program mode. When it is cleared to 0, program mode is cancelled.

18.5.2 Flash Memory Control Register 2 (FLMCR2)

FLMCR2 monitors the state of flash memory programming/erasing protection (error protection) and sets up the flash memory to transit to programming/erasing mode. FLMCR2 is initialized to H'00 by a reset or in hardware standby mode. The ESU and PSU bits are cleared to 0 in software standby mode, sub-active mode, sub-sleep mode, or watch mode, or when the SWE bit in FLMCR1 is cleared to 0.

Bit	Bit Name	Initial Value	R/W	Description
7	FLER	0	R	Flash memory error Indicates that an error has occurred during flash memory programming/erasing. When this bit is set to 1, flash memory goes to the error-protection state. For details, see section 18.9.3, Error Protection.
6 to 2	—	All 0	R/(W)	Reserved The initial values should not be modified.
1	ESU	0	R/W	Erase Setup When this bit is set to 1 while SWE = 1, the flash memory transits to the erase setup state. When it is cleared to 0, the erase setup state is cancelled. Set this bit to 1 before setting the E bit in FLMCR1 to 1.
0	PSU	0	R/W	Program Setup When this bit is set to 1 while SWE = 1, the flash memory transits to the program setup state. When it is cleared to 0, the program setup state is cancelled. Set this bit to 1 before setting the P bit in FLMCR1 to 1.

18.5.3 Erase Block Registers 1 and 2 (EBR1, EBR2)

EBR1 and EBR2 are used to specify the flash memory erase block. EBR1 and EBR2 are initialized to H'00 by a reset, or in hardware standby mode, software standby mode, sub-active mode, sub-sleep mode, or watch mode, or when the SWE bit in FLMCR1 is cleared to 0. Set only one bit to 1 at a time, otherwise all bits in EBR1 and EBR2 are automatically cleared to 0.

- EBR1

Bit	Bit Name	Initial Value	R/W	Description
7 to 0	—	All 0	R/(W)	Reserved

The initial values should not be modified.

- EBR2

Bit	Bit Name	Initial Value	R/W	Description
7	EB7	0	R/W*	When this bit is set to 1, 8 Kbytes of EB7 (H'00E000 to H'00FFFF) are to be erased.
6	EB6	0	R/W	When this bit is set to 1, 8 Kbytes of EB6 (H'00C000 to H'00DFFF) are to be erased.
5	EB5	0	R/W	When this bit is set to 1, 16 Kbytes of EB5 (H'008000 to H'00BFFF) are to be erased.
4	EB4	0	R/W	When this bit is set to 1, 28 Kbytes of EB4 (H'001000 to H'007FFF) are to be erased.
3	EB3	0	R/W	When this bit is set to 1, 1 Kbyte of EB3 (H'000C00 to H'000FFF) is to be erased.
2	EB2	0	R/W	When this bit is set to 1, 1 Kbyte of EB2 (H'000800 to H'000BFF) is to be erased.
1	EB1	0	R/W	When this bit is set to 1, 1 Kbyte of EB1 (H'000400 to H'0007FF) is to be erased.
0	EB0	0	R/W	When this bit is set to 1, 1 Kbyte of EB0 (H'000000 to H'0003FF) is to be erased.

Note: * In normal mode, this bit is always read as 0 and cannot be modified.

18.6 Operating Modes

The flash memory is connected to the CPU via a 16-bit data bus, enabling byte data and word data to be accessed in a single state. Even addresses are connected to the upper 8 bits and odd addresses are connected to the lower 8 bits. Note that word data must start from an even address.

In normal mode (mode 3), up to 56 Kbytes of ROM can be used.

Table 18.3 Operating Modes and ROM

Operating Modes			Mode Pins		
MCU	CPU		MD1	MD0	On-Chip ROM
Operating Mode	Operating Mode	Mode			
Mode 2	Advanced	Single-chip mode	1	0	Enabled (64 Kbytes)
Mode 3	Normal	Single-chip mode	1	1	Enabled (56 Kbytes)

18.7 On-Board Programming Modes

An on-board programming mode is used to perform on-chip flash memory programming, erasing, and verification. This LSI has two on-board programming modes: boot mode and user program mode. Table 18.4 shows pin settings for boot mode. In user program mode, operation by software is enabled by setting control bits. For details on flash memory mode transitions, see figure 18.2.

Table 18.4 On-Board Programming Mode Settings

Mode Setting		MD1	MD0	P92	P91	P90
Boot mode		0	0	1*	1*	1*
User program mode	Mode 2 (advanced mode)	1	0	—	—	—
	Mode 3 (normal mode)	1	1	—	—	—

Note: * Can be used as an I/O port after the boot mode activation.

18.7.1 Boot Mode

Table 18.5 shows the boot mode operations between reset end and branching to the programming control program.

1. When boot mode is used, the flash memory programming control program must be prepared in the host beforehand. Prepare a programming control program in accordance with the description in section 18.8, Flash Memory Programming/Erasing. In boot mode, if any data exists in the flash memory (except in the case that all data are 1), all blocks in the flash memory are erased. Use boot mode at initial writing in the on-board state, or forced recovery when user program mode cannot be executed because the program to be initiated in user program mode was mistakenly erased.
2. The SCI_1 should be set to asynchronous mode, and the transfer format as follows: 8-bit data, 1 stop bit, and no parity.
3. When the boot program is initiated, this LSI measures the low-level period of asynchronous SCI communication data (H'00) transmitted continuously from the host. This LSI then calculates the bit rate of transmission from the host, and adjusts the SCI_1 bit rate to match that of the host. The reset should end with the RxD1 pin high. The RxD1 and TxD1 pins should be pulled up on the board if necessary. After the reset ends, it takes approximately 100 states before this LSI is ready to measure the low-level period.
4. After matching the bit rates, this LSI transmits one H'00 byte to the host to indicate the end of bit rate adjustment. The host should confirm that this adjustment end indication (H'00) has been received normally, and transmit one H'55 byte to this LSI. If reception could not be performed normally, initiate boot mode again by a reset. Depending on the host's transfer bit rate and system clock frequency of this LSI, there will be a discrepancy between the bit rates of the host and this LSI. To operate the SCI properly, set the host's transfer bit rate and system clock frequency of this LSI within the ranges listed in table 18.6.
5. In boot mode, a part of the on-chip RAM area is used by the boot program. Addresses H'FFE080 to H'FFE87F*¹ is the area to which the programming control program is transferred from the host. Note, however, that ID codes are assigned to addresses H'FFE080 to H'FFE087. The boot program area cannot be used until the execution state in boot mode switches to the programming control program. Figure 18.6 shows the on-chip RAM area in boot mode.
6. Before branching to the programming control program (H'FFE088 in the RAM area), this LSI terminates transfer operations by the SCI_1 (by clearing the RE and TE bits in SCR to 0), but the adjusted bit rate value remains set in BRR. Therefore, the programming control program can still use it for transfer of write data or verify data with the host. The TxD1 pin is in high-level output state. The contents of the CPU general registers are undefined immediately after branching to the programming control program. These registers must be initialized at the beginning of the programming control program, since the stack pointer (SP), in particular, is used implicitly in subroutine calls, etc.

7. Boot mode can be cleared by a reset. Cancel the reset*² after driving the reset pin low, waiting at least 20 states, and then setting the mode pins. Boot mode is also cleared when a WDT overflow occurs.
8. Do not change the mode pin input levels in boot mode.
9. All interrupts are disabled during programming or erasing of the flash memory.

- Notes: 1. Some parts of this area are reserved only for boot mode and therefore should not be used for any other purpose.
2. After reset is cancelled, mode pin input settings must satisfy the mode programming setup time ($t_{MDS} = 4$ states).

Table 18.5 Boot Mode Operation

Item	Host Operation	Communications Contents	LSI Operation
	Processing Contents		Processing Contents
Boot mode start			Branches to boot program at reset-start. 
Bit rate adjustment	Continuously transmits data H'00 at specified bit rate. ↓ Transmits data H'55 when data H'00 is received error-free. ↓ Receives data H'AA. ←	H'00, H'00 ··· H'00 → ← H'00 ← H'55 H'AA →	<ul style="list-style-type: none"> Measures low-level period of receive data H'00. Calculates bit rate and sets it in BRR of SCI_1. Transmits data H'00 to host as adjustment end indication. ↓ After receiving data H'55, transmits data H'AA to host.
Transfer of programming control program	Transmits number of bytes (N) of programming control program to be transferred as 2-byte data (low-order byte following high-order byte). ↓ Transmits 1-byte of programming control program (repeated for N times).	High-order byte and low-order byte → ← Echoback H'XX → ← Echoback	Echobacks the 2-byte data received to host. ↓ Echobacks received data to host and also transfers it to RAM (repeated for N times).
Flash memory erase	↓ Boot program erase error ↓ Receives data H'AA. ←	← H'FF H'AA →	Checks flash memory data, erases all flash memory blocks in case of written data existing, and transmits data H'AA to host. (If erase could not be done, transmits data H'FF to host and aborts operation.) ↓
			↓ Branches to programming control program transferred to on-chip RAM and starts execution.

Table 18.6 System Clock Frequencies for which Automatic Adjustment of LSI Bit Rate is Possible

Host Bit Rate	System Clock Frequency Range of LSI
19200 bps	8 to 10 MHz
9600 bps	4 to 10 MHz
4800 bps	4 to 10 MHz

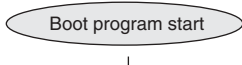
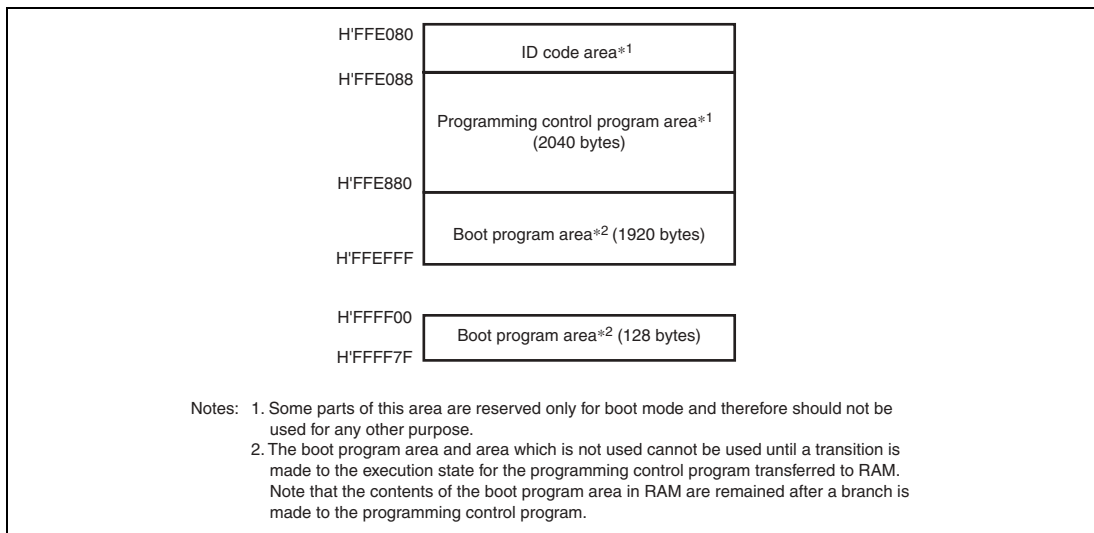

Figure 18.6 On-Chip RAM Area in Boot Mode

In boot mode, this LSI checks the contents of the 8-byte ID code area as shown below to confirm that the programming control program corresponds with this LSI. To originally write a programming control program to be used in boot mode, the above 8-byte ID code must be added at the beginning of the program.

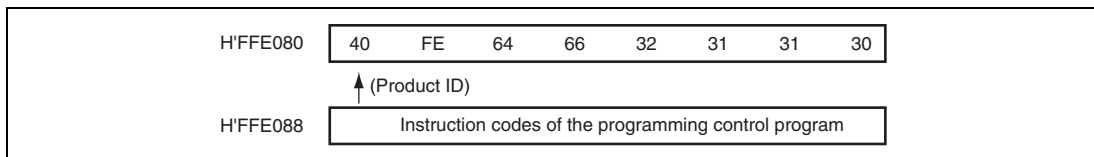

Figure 18.7 ID Code Area

18.7.2 User Program Mode

On-board programming/erasing of an individual flash memory block can also be performed in user program mode by branching to a user program/erase control program. The user must set branching conditions and provide on-board means of supplying programming data. The flash memory must contain the user program/erase control program or a program which provides the user program/erase control program from external memory. Because the flash memory itself cannot be read during programming/erasing, transfer the user program/erase control program to on-chip RAM, as like in boot mode. Figure 18.8 shows a sample procedure for programming/erasing in user program mode. Prepare a user program/erase control program in accordance with the description in section 18.8, Flash Memory Programming/Erasing.

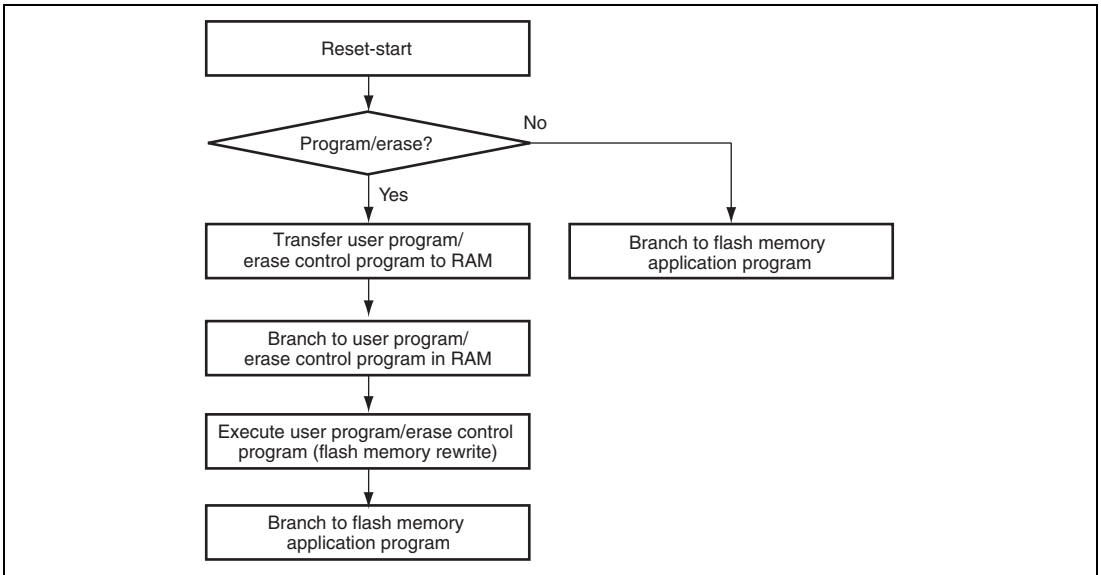

Figure 18.8 Programming/Erasing Flowchart Example in User Program Mode

18.8 Flash Memory Programming/Erasing

A software method, using the CPU, is employed to program and erase flash memory in the on-board programming modes. Depending on the FLMCR1 and FLMCR2 settings, the flash memory operates in one of the following four modes: program mode, program-verify mode, erase mode, and erase-verify mode. The programming control program in boot mode and the user program/erase control program in user program mode use these operating modes in combination to perform programming/erasing. Flash memory programming and erasing should be performed in accordance with the descriptions in section 18.8.1, Program/Program-Verify and section 18.8.2, Erase/Erase-Verify, respectively.

18.8.1 Program/Program-Verify

When writing data or programs to the flash memory, the program/program-verify flowchart shown in figure 18.9 should be followed. Performing programming operations according to this flowchart will enable data or programs to be written to the flash memory without subjecting this LSI to voltage stress or sacrificing program data reliability.

1. Programming must be done to an empty address. Do not reprogram an address to which programming has already been performed.
2. Programming should be carried out 128 bytes at a time. A 128-byte data transfer must be performed even if writing fewer than 128 bytes. In this case, H'FF data must be written to the extra addresses.
3. Prepare the following data storage areas in RAM: a 128-byte programming data area, a 128-byte reprogramming data area, and a 128-byte additional-programming data area. Perform reprogramming data computation and additional programming data computation according to figure 18.9.
4. Consecutively transfer 128 bytes of data in byte units from the reprogramming data area or additional-programming data area to the flash memory. The program address and 128-byte data are latched in the flash memory. The lower 8 bits of the start address in the flash memory destination area must be H'00 or H'80.
5. The time during which the P bit is set to 1 is the programming time. Figure 18.9 shows the allowable programming times.
6. The watchdog timer (WDT) is set to prevent overprogramming due to program runaway, etc. The overflow cycle should be longer than $(y + z2 + \alpha + \beta) \mu\text{s}$.
7. For a dummy write to a verify address, write 1-byte data H'FF to an address whose lower 2 bits are B'00. Verify data can be read in words from the address to which a dummy write was performed.
8. The maximum number of repetitions of the program/program-verify sequence to the same bit is (N).

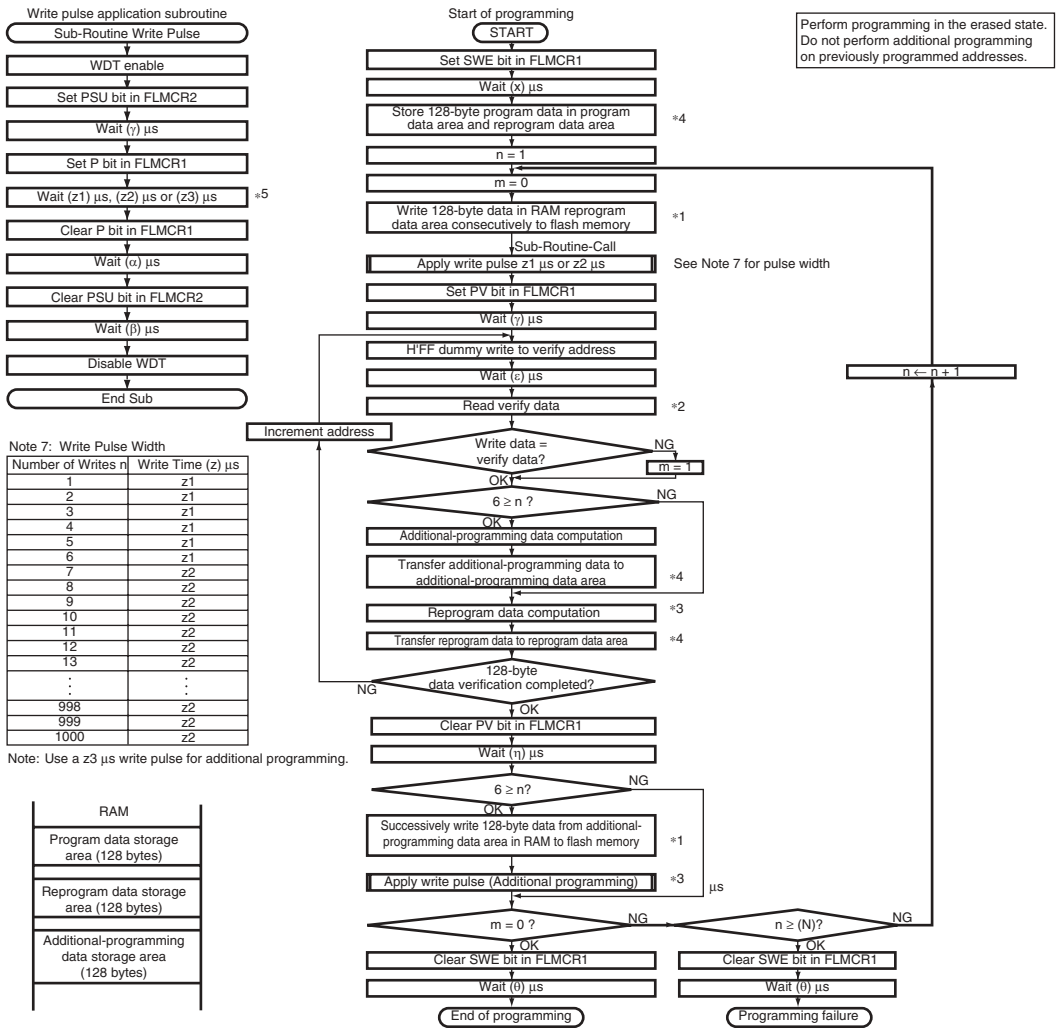

- Notes:
- Data transfer is performed by byte transfer. The lower 8 bits of the first address written to must be H'00 or H'80. A 128-byte data transfer must be performed even if writing fewer than 128 bytes; in this case, H'FF data must be written to the extra addresses.
 - Verify data is read in 16-bit (word) units.
 - Even bits for which programming has been completed will be subjected to programming once again if the result of the subsequent verify operation is NG.
 - A 128-byte area for storing program data, a 128-byte area for storing reprogram data, and a 128-byte area for storing additional data must be provided in RAM. The contents of the reprogram data area and additional data area are modified as programming proceeds.
 - A write pulse of z1 μs or z2 μs is applied according to the progress of the programming operation. See Note 7 for details of the pulse widths. When writing of additional-programming data is executed, a z3 μs write pulse should be applied. Reprogram data 'X' means reprogram data when the write pulse is applied.
 - The values of x, y, z1, z2, α, β, γ, ε, η, θ, and N are shown in section 22.5, Flash Memory Characteristics.

Reprogram Data Computation Table

Original Data (D)	Verify Data (V)	Reprogram Data (X)	Comments
0	0	1	Programming completed
0	1	0	Programming incomplete; reprogram
1	0	1	
1	1	1	Still in erased state; no action

Additional-Programming Data Computation Table

Reprogram Data (X')	Verify Data (V)	Additional-Programming Data (Y)	Comments
0	0	0	Additional programming to be executed
0	1	1	Additional programming not to be executed
1	0	1	
1	1	1	Additional programming not to be executed

Figure 18.9 Program/Program-Verify Flowchart

18.8.2 Erase/Erase-Verify

When erasing flash memory, the erase/erase-verify flowchart shown in figure 18.10 should be followed.

1. Prewriting (setting erase block data to all 0) is not necessary.
2. Erasing is performed in block units. Make only a single-block specification in erase block registers 1 and 2 (EBR1 and EBR2). To erase multiple blocks, each block must be erased in turn.
3. The time during which the E bit is set to 1 is the flash memory erase time.
4. The watchdog timer (WDT) is set to prevent overprogramming due to program runaway, etc. An overflow cycle of approximately $(y + z + \alpha + \beta)$ ms is allowed.
5. For a dummy write to a verify address, write 1-byte data H'FF to an address whose lower two bits are B'00. Verify data can be read in longwords from the address to which a dummy write was performed.
6. If the read data is unerased, set erase mode again, and repeat the erase/erase-verify sequence as before. The maximum number of repetitions of the erase/erase-verify sequence is N.

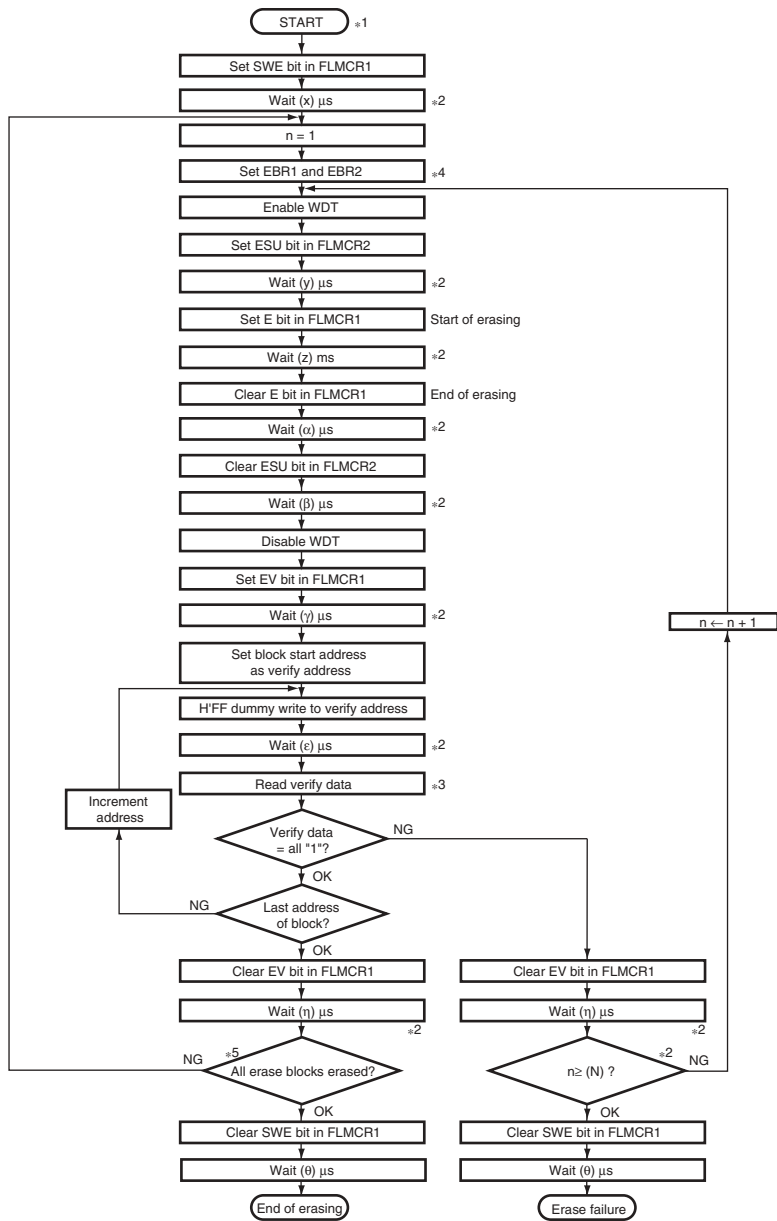

- Notes:
1. Prewriting (writing 0 to all data in erased block) is not necessary.
 2. The values of x , y , z , α , β , γ , ϵ , η , θ , and N are shown in section 22.5, Flash Memory Characteristics.
 3. Verify data is read in 16-bit (word) units.
 4. Set only a single bit in EBR1 and EBR2. Do not set more than one bit.
 5. Erasing is performed in block units. To erase multiple blocks, each block must be erased in turn.

Figure 18.10 Erase/Erase-Verify Flowchart

18.9 Program/Erase Protection

There are three kinds of flash memory program/erase protection: hardware protection, software protection, and error protection.

18.9.1 Hardware Protection

Hardware protection is a state in which programming/erasing of flash memory is forcibly disabled or aborted by a reset (including WDT overflow reset), or a transition to hardware standby mode, software standby mode, sub-active mode, sub-sleep mode or watch mode. Flash memory control registers 1 and 2 (FLMCR1 and FLMCR2) and erase block registers 1 and 2 (EBR1 and EBR2) are initialized. In a reset via the $\overline{\text{RES}}$ pin, the reset state is not entered unless the $\overline{\text{RES}}$ pin is held low until oscillation stabilizes after powering on. In the case of a reset during operation, hold the $\overline{\text{RES}}$ pin low for the $\overline{\text{RES}}$ pulse width specified in the AC Characteristics section.

18.9.2 Software Protection

Software protection can be implemented against programming/erasing of all flash memory blocks by clearing the SWE bit in FLMCR1 to 0. When software protection is in effect, setting the P or E bit in FLMCR1 does not cause a transition to program mode or erase mode. By setting the erase block registers 1 and 2 (EBR1 and EBR2), erase protection can be set for individual blocks. When EBR1 and EBR2 are set to H'00, erase protection is set for all blocks.

18.9.3 Error Protection

In error protection, an error is detected when the CPU's runaway occurs during flash memory programming/erasing, or operation is not performed in accordance with the program/erase algorithm, and the program/erase operation is aborted. Aborting the program/erase operation prevents damage to the flash memory due to overprogramming or overerasing.

When the following errors are detected during programming/erasing of flash memory, the FLER bit in FLMCR2 is set to 1, and the error protection state is entered.

- When the flash memory of is read during programming/erasing (including vector read and instruction fetch)
- Immediately after exception handling (excluding a reset) during programming/erasing
- When a SLEEP instruction is executed (transits to software standby mode, sleep mode, sub-active mode, sub-sleep mode, or watch mode) during programming/erasing

The FLMCR1, FLMCR2, EBR1, and EBR2 settings are retained, but program mode or erase mode is aborted at the point at which the error occurred. Program mode or erase mode cannot be entered by setting the P or E bit to 1. However, because the PV and EV bit settings are retained, a transition to verify mode can be made. The error protection state can be cancelled by a reset or in hardware standby mode.

18.10 Interrupts during Flash Memory Programming/Erasing

In order to give the highest priority to programming/erasing operations, disable all interrupts including NMI input during flash memory programming/erasing (the P or E bit in FLMCR1 is set to 1) or boot program execution*¹.

1. If an interrupt is generated during programming/erasing, operation in accordance with the program/erase algorithm is not guaranteed.
2. CPU runaway may occur because normal vector reading cannot be performed in interrupt exception handling during programming/erasing*².
3. If an interrupt occurs during boot program execution, the normal boot mode sequence cannot be executed.

Notes: 1. Interrupt requests must be disabled inside and outside the CPU until the programming control program has completed programming.

2. The vector may not be read correctly for the following two reasons:

If flash memory is read while being programmed or erased (while the P or E bit in FLMCR1 is set to 1), correct read data will not be obtained (undefined values will be returned).

If the interrupt entry in the vector table has not been programmed yet, interrupt exception handling will not be executed correctly.

18.11 Programmer Mode

In programmer mode, the on-chip flash memory can be programmed/erased by a PROM programmer via a socket adapter, just like for a discrete flash memory. Use a PROM programmer that supports the Renesas 64-Kbyte flash memory on-chip MCU device*. Figure 18.11 shows a memory map in programmer mode.

Note: Set the programming voltage of the PROM programmer to 3.3V.

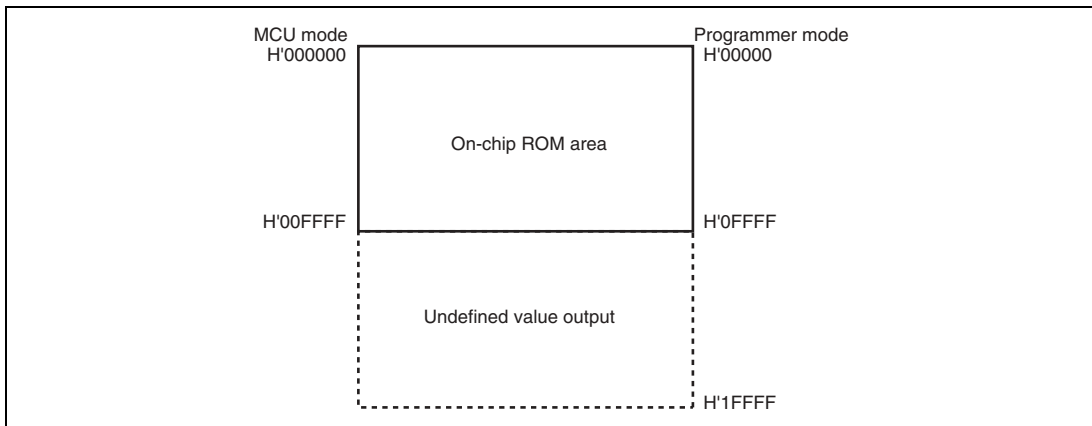

Figure 18.11 Memory Map in Programmer Mode

18.12 Usage Notes

The following lists notes on the use of on-board programming modes and programmer mode.

1. Perform programming/erasing with the specified voltage and timing.
If a voltage higher than the rated voltage is applied, the product may be fatally damaged. Use a PROM programmer that supports the Renesas 64-Kbyte flash memory on-chip MCU device at 3.3 V. Do not set the programmer to HN28F101 or the programming voltage to 5.0 V.
2. Notes on power on/off
At powering on or off the Vcc power supply, fix the $\overline{\text{RES}}$ pin to low and set the flash memory to hardware protection state. This power on/off timing must also be satisfied at a power-off and power-on caused by a power failure and other factors.
3. Perform flash memory programming/erasing in accordance with the recommended algorithm
In the recommended algorithm, flash memory programming/erasing can be performed without subjecting this LSI to voltage stress or sacrificing program data reliability. When setting the P or E bit in FLMCR1 to 1, set the watchdog timer against program runaway.
4. Do not set/clear the SWE bit during program execution in the flash memory.
Do not set/clear the SWE bit during program execution in the flash memory. An interval of at least 100 μs is necessary between program execution or data reading in flash memory and SWE bit clearing. When the SWE bit is set to 1, flash memory data can be modified, however, flash memory data can be read only in program-verify or erase-verify mode. Do not access the flash memory for a purpose other than verification during programming/erasing. Do not clear the SWE bit during programming, erasing, or verifying.
5. Do not use interrupts during flash memory programming/erasing
In order to give the highest priority to programming/erasing operation, disable all interrupts including NMI input when the flash memory is programmed or erased.
6. Do not perform additional programming. Programming must be performed in the erased state.
Program the area with 128-byte programming-unit blocks in on-board programming or programmer mode only once. Perform programming in the state where the programming-unit block is fully erased.
7. Ensure that the PROM programmer is correctly attached before programming.
If the socket, socket adapter, or product index does not match the specifications, too much current flows and the product may be damaged.
8. Do not touch the socket adapter or LSI while programming.
Touching either of these can cause contact faults and write errors.

Section 19 Clock Pulse Generator

This LSI incorporates a clock pulse generator, which generates the system clock (ϕ), bus master clock, and internal clock.

The clock pulse generator consists of an oscillator, duty correction circuit, clock select circuit, medium-speed clock divider, bus master clock select circuit, subclock input circuit, and waveform forming circuit. Figure 19.1 shows a block diagram of the clock pulse generator.

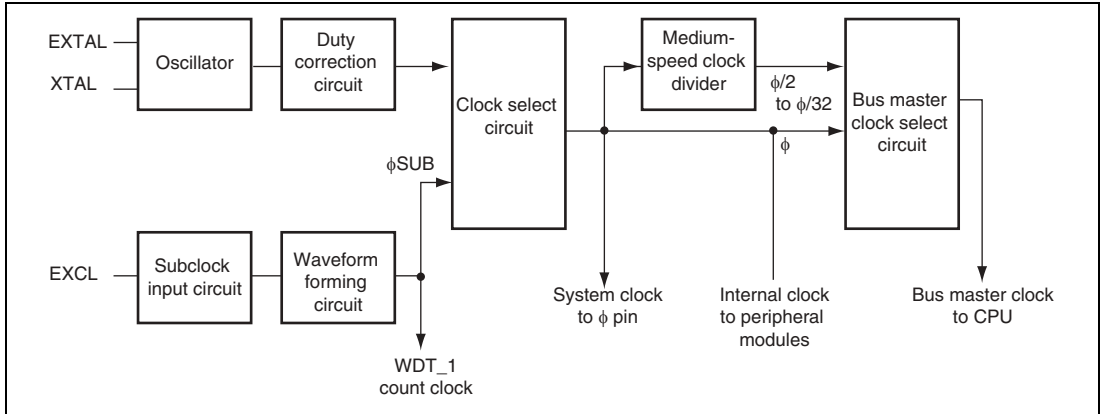

Figure 19.1 Block Diagram of Clock Pulse Generator

The bus master clock is selected as either high-speed mode or medium-speed mode by software according to the settings of the SCK2 to SCK0 bits in the standby control register. For details on the standby control register, refer to section 20.1.1, Standby Control Register (SBYCR).

The subclock input is controlled by software according to the EXCLE bit setting in the low power control register. For details on the low power control register, refer to section 20.1.2, Low Power Control Register (LPWRCR).

19.1 Oscillator

Clock pulses can be supplied either by connecting a crystal resonator, or by providing external clock input.

19.1.1 Connecting Crystal Resonator

Figure 19.2 shows a typical method of connecting a crystal resonator. An appropriate damping resistance R_d , given in table 19.1, should be used. An AT-cut parallel-resonance crystal resonator should be used.

Figure 19.3 shows the equivalent circuit of a crystal resonator. A resonator having the characteristics given in table 19.2 should be used.

A crystal resonator with frequency identical to that of the system clock (ϕ) should be used.

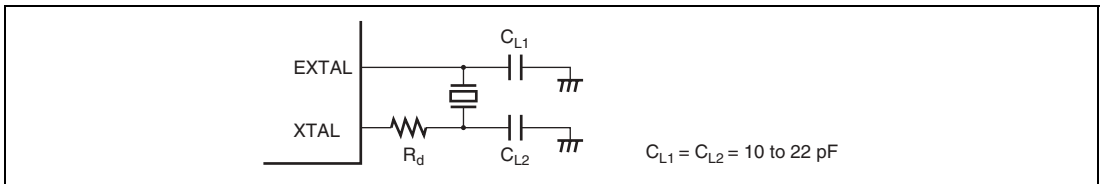

Figure 19.2 Typical Connection to Crystal Resonator

Table 19.1 Damping Resistance Values

Frequency (MHz)	4	8	10
R_d (Ω)	500	200	0

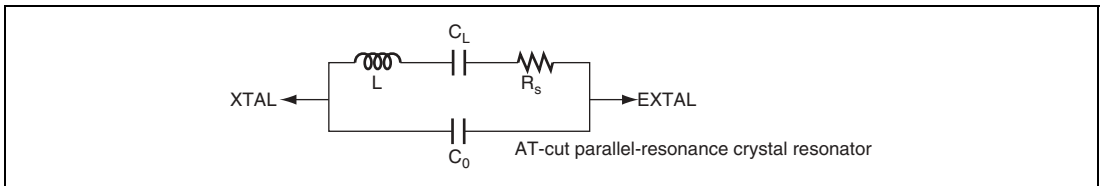

Figure 19.3 Equivalent Circuit of Crystal Resonator

Table 19.2 Crystal Resonator Parameters

Frequency (MHz)	4	8	10
R_s (max) (Ω)	120	80	70
C_0 (max) (pF)	7	7	7

19.1.2 External Clock Input Method

Figure 19.4 shows a typical method of connecting an external clock signal. To leave the XTAL pin open, incidental capacitance should be 10 pF or less.

To input an inverted clock to the XTAL pin, the external clock should be set to high in standby mode, subactive mode, subsleep mode, and watch mode. External clock input conditions are shown in table 19.3. The frequency of the external clock should be the same as that of the system clock (ϕ).

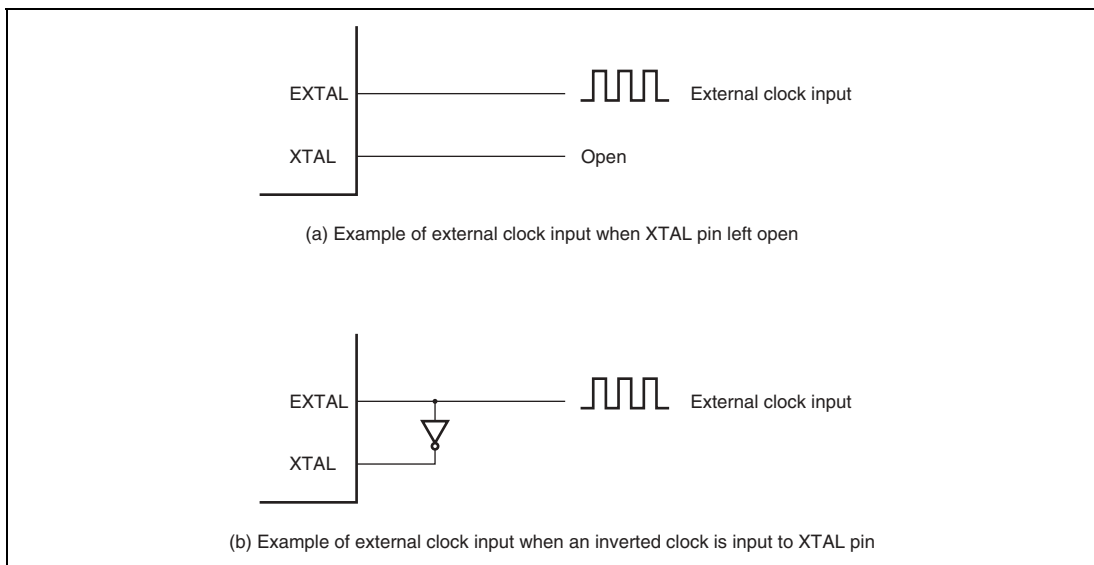

Figure 19.4 Example of External Clock Input

Table 19.3 External Clock Input Conditions

Item	Symbol	$V_{CC} = 3.0 \text{ to } 3.6 \text{ V}$		Unit	Test Conditions	
		Min	Max			
External clock input pulse width low level	t_{EXL}	40	—	ns	Figure 19.5	
External clock input pulse width high level	t_{EXH}	40	—	ns		
External clock rising time	t_{EXr}	—	10	ns		
External clock falling time	t_{EXf}	—	10	ns		
Clock pulse width low level	t_{CL}	0.4	0.6	t_{cyc}	$\phi \geq 5 \text{ MHz}$	Figure 22.5
		80	—	ns	$\phi < 5 \text{ MHz}$	
Clock pulse width high level	t_{CH}	0.4	0.6	t_{cyc}	$\phi \geq 5 \text{ MHz}$	
		80	—	ns	$\phi < 5 \text{ MHz}$	

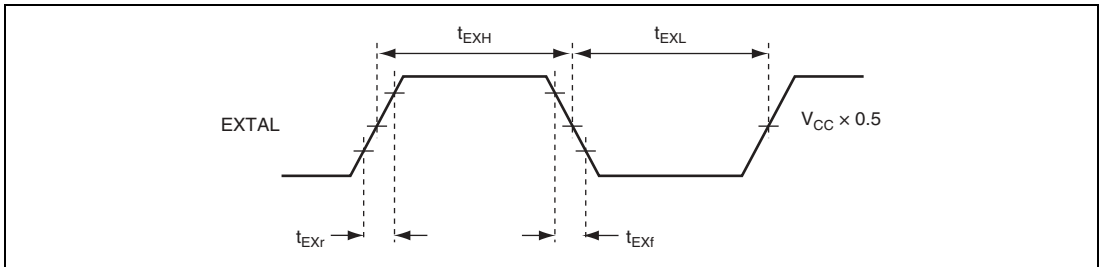

Figure 19.5 External Clock Input Timing

The oscillator and duty correction circuit have a function to adjust the waveform of the external clock input that is input to the EXTAL pin. When a specified clock signal is input to the EXTAL pin, internal clock signal output is determined after the external clock output stabilization delay time (t_{DEXT}) has passed. As the clock signal output is not determined during the t_{DEXT} cycle, a reset signal should be set to low to hold it in reset state. Table 19.4 shows the external clock output stabilization delay time. Figure 19.6 shows the timing of the external clock output stabilization delay time.

Table 19.4 External Clock Output Stabilization Delay Time

Condition: $V_{CC} = 3.0 \text{ V to } 3.6 \text{ V}$, $V_{SS} = 0 \text{ V}$

Item	Symbol	Min.	Max.	Unit	Remarks
External clock output stabilization delay time	t_{DEXT}^*	500	—	μs	Figure 19.6

Note: * t_{DEXT} includes a $\overline{\text{RES}}$ pulse width (t_{RESW}).

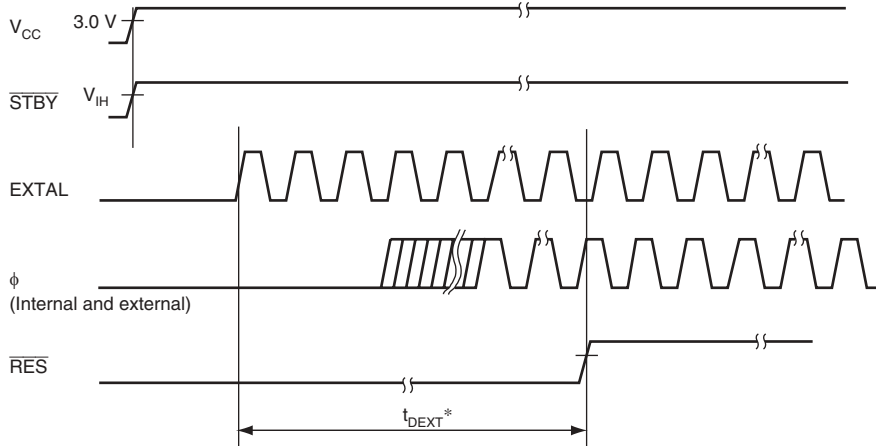

Note: * The external clock output stabilization delay time (t_{DEXT}) includes a $\overline{\text{RES}}$ pulse width (t_{RESW}).

Figure 19.6 Timing of External Clock Output Stabilization Delay Time

19.2 Duty Correction Circuit

The duty correction circuit is valid when the oscillating frequency is 5 MHz or more. It corrects the duty of a clock that is output from the oscillator, and generates the system clock (ϕ).

19.3 Medium-Speed Clock Divider

The medium-speed clock divider divides the system clock (ϕ), and generates $\phi/2$, $\phi/4$, $\phi/8$, $\phi/16$, and $\phi/32$ clocks.

19.4 Bus Master Clock Select Circuit

The bus master clock select circuit selects a clock to supply the bus master with either the system clock (ϕ) or medium-speed clock ($\phi/2$, $\phi/4$, $\phi/8$, $\phi/16$, or $\phi/32$) by the SCK2 to SCK0 bits in SBYCR.

19.5 Subclock Input Circuit

The subclock input circuit controls subclock input from the EXCL pin. To use the subclock, a 32.768-kHz external clock should be input from the EXCL pin. At this time, the P96DDR bit in P9DDR should be cleared to 0, and the EXCLE bit in LPWRCR should be set to 1.

Subclock input conditions are shown in table 19.5. When the subclock is not used, subclock input should not be enabled.

Table 19.5 Subclock Input Conditions

Item	Symbol	V _{CC} = 3.0 to 3.6 V			Unit	Measurement Condition
		Min	Typ	Max		
Subclock input pulse width low level	t _{EXCLL}	—	15.26	—	μs	Figure 19.7
Subclock input pulse width high level	t _{EXCLH}	—	15.26	—	μs	
Subclock input rising time	t _{EXCLr}	—	—	10	ns	
Subclock input falling time	t _{EXCLf}	—	—	10	ns	

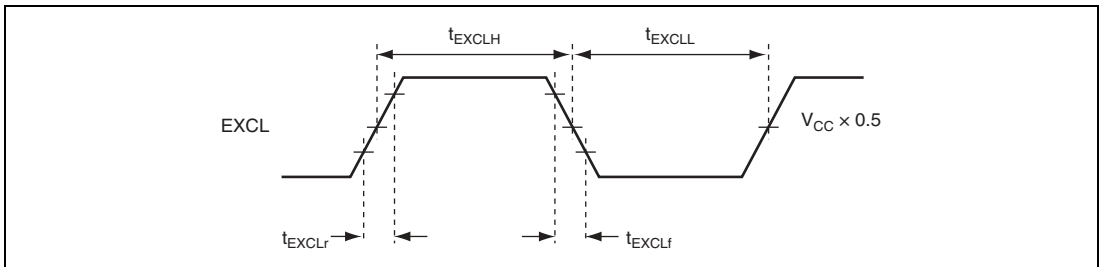

Figure 19.7 Subclock Input Timing

19.6 Waveform Forming Circuit

To remove noise from the subclock input at the EXCL pin, the subclock is sampled by a divided ϕ clock. The sampling frequency is set by the NESEL bit in LPWRCR.

The subclock is not sampled in subactive mode, subsleep mode, or watch mode.

19.7 Clock Select Circuit

The clock select circuit selects the system clock that is used in this LSI.

A clock generated by an oscillator to which the EXTAL and XTAL pins are input is selected as a system clock when returning from high-speed mode, medium-speed mode, sleep mode, reset state, or standby mode.

A subclock input from the EXCL pin is selected as a system clock in subactive mode, subsleep mode, or watch mode. At this time, modules such as the CPU, TMR_0, TMR_1, WDT_0, WDT_1, ports, and interrupt controller and their functions operate depending on the ϕ SUB. The count clock and sampling clock for each timer are divided ϕ SUB clocks.

19.8 Usage Notes

19.8.1 Note on Resonator

Since all kinds of characteristics of the resonator are closely related to the board design by the user, use the example of resonator connection in this document for only reference; be sure to use an resonator that has been sufficiently evaluated by the user. Consult with the resonator manufacturer about the resonator circuit ratings which vary depending on the stray capacitances of the resonator and installation circuit. Make sure the voltage applied to the oscillator pins does not exceed the maximum rating.

19.8.2 Notes on Board Design

When using a crystal resonator, the crystal resonator and its load capacitors should be placed as close as possible to the XTAL and EXTAL pins.

Other signal lines should be routed away from the oscillator circuit to prevent inductive interference with the correct oscillation as shown in figure 19.8.

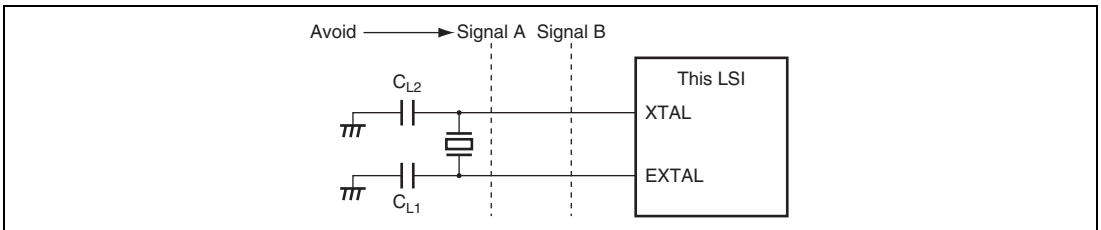

Figure 19.8 Note on Board Design of Oscillator Circuit Section

Section 20 Power-Down Modes

For operating modes after the reset state is cancelled, this LSI has not only the normal program execution state but also seven power-down modes in which power consumption is significantly reduced. In addition, there is also module stop mode in which reduced power consumption can be achieved by individually stopping on-chip peripheral modules.

- Medium-speed mode
System clock frequency for the CPU operation can be selected as $\phi/2$, $\phi/4$, $\phi/8$, $\phi/16$, or $\phi/32$.
- Subactive mode
The CPU operates based on the subclock and on-chip peripheral modules other than TMR_0, TMR_1, WDT_0, and WDT_1 stop operating.
- Sleep mode
The CPU stops but on-chip peripheral modules continue operating.
- Subsleep mode
The CPU and on-chip peripheral modules other than TMR_0, TMR_1, WDT_0, and WDT_1 stop operating.
- Watch mode
The CPU and on-chip peripheral modules other than WDT_1 stop operating.
- Software standby mode
Clock oscillation stops, and the CPU and on-chip peripheral modules stop operating.
- Hardware standby mode
Clock oscillation stops, and the CPU and on-chip peripheral modules enter reset state.
- Module stop mode
Independently of above operating modes, on-chip peripheral modules that are not used can be stopped individually.

20.1 Register Descriptions

Power-down modes are controlled by the following registers. To access SBYCR, LPWRCR, MSTPCRH, and MSTPCRL, the FLSHE bit in the serial timer control register (STCR) must be cleared to 0. For details on STCR, see section 3.2.3, Serial Timer Control Register (STCR).

- Standby control register (SBYCR)
- Low power control register (LPWRCR)
- Module stop control register H (MSTPCRH)
- Module stop control register L (MSTPCRL)

20.1.1 Standby Control Register (SBYCR)

SBYCR controls power-down modes.

Bit	Bit Name	Initial Value	R/W	Description
7	SSBY	0	R/W	<p>Software Standby</p> <p>Specifies the operating mode to be entered after executing the SLEEP instruction.</p> <p>When the SLEEP instruction is executed in high-speed mode or medium-speed mode:</p> <p>0: Shifts to sleep mode</p> <p>1: Shifts to software standby mode, subactive mode, or watch mode</p> <p>When the SLEEP instruction is executed in subactive mode:</p> <p>0: Shifts to subsleep mode</p> <p>1: Shifts to watch mode or high-speed mode</p> <p>Note that the SSBY bit is not changed even if a mode transition occurs by an interrupt.</p>
6	STS2	0	R/W	Standby Timer Select 2 to 0
5	STS1	0	R/W	<p>Selects the wait time for clock stabilization from clock oscillation start when canceling software standby mode, watch mode, or subactive mode. Select a wait time of 8 ms (oscillation stabilization time) or more, depending on the operating frequency. Table 20.1 shows the relationship between the STS2 to STS0 values and wait time.</p> <p>With an external clock, there are no specific wait requirements. Normally the minimum value is recommended.</p>
4	STS0	0	R/W	
3	—	0	R	<p>Reserved</p> <p>This bit is always read as 0, and cannot be modified.</p>
2	SCK2	0	R/W	System Clock Select 2 to 0
1	SCK1	0	R/W	<p>Selects a clock for the bus master in high-speed mode or medium-speed mode.</p> <p>When making a transition to subactive mode or watch mode, SCK2 to SCK0 must be cleared to 0.</p> <p>000: High-speed mode</p> <p>001: Medium-speed clock: $\phi/2$</p> <p>010: Medium-speed clock: $\phi/4$</p> <p>011: Medium-speed clock: $\phi/8$</p> <p>100: Medium-speed clock: $\phi/16$</p> <p>101: Medium-speed clock: $\phi/32$</p> <p>11X: —</p>
0	SCK0	0	R/W	

[Legend]

X: Don't care

Table 20.1 Operating Frequency and Wait Time

STS2	STS1	STS0	Wait Time	10 MHz	8 MHz	6 MHz	4 MHz	Unit
0	0	0	8192 states	0.8	1.0	1.3	20.	ms
0	0	1	16384 states	1.6	2.0	2.7	4.1	
0	1	0	32768 states	3.3	4.1	5.5	8.2	
0	1	1	65536 states	6.6	8.2	10.9	16.4	
1	0	0	131072 states	13.1	16.4	21.8	32.8	
1	0	1	262144 states	26.2	32.8	43.6	65.6	
1	1	0	Reserved	—	—	—	—	
1	1	1	Reserved	—	—	—	—	

Shaded cells indicate the recommended specification.

20.1.2 Low-Power Control Register (LPWRCR)

LPWRCR controls power-down modes.

Bit	Bit Name	Initial Value	R/W	Description
7	DTON	0	R/W	<p>Direct Transfer On Flag</p> <p>Specifies the operating mode to be entered after executing the SLEEP instruction.</p> <p>When the SLEEP instruction is executed in high-speed mode or medium-speed mode:</p> <p>0: Shifts to sleep mode, software standby mode, or watch mode</p> <p>1: Shifts directly to subactive mode, or shifts to sleep mode or software standby mode</p> <p>When the SLEEP instruction is executed in subactive mode:</p> <p>0: Shifts to subsleep mode or watch mode</p> <p>1: Shifts directly to high-speed mode, or shifts to subsleep mode</p>

Bit	Bit Name	Initial Value	R/W	Description
6	LSON	0	R/W	<p>Low-Speed On Flag</p> <p>Specifies the operating mode to be entered after executing the SLEEP instruction. This bit also controls whether to shift to high-speed mode or subactive mode when watch mode is cancelled.</p> <p>When the SLEEP instruction is executed in high-speed mode or medium-speed mode:</p> <p>0: Shifts to sleep mode, software standby mode, or watch mode</p> <p>1: Shifts to watch mode or subactive mode</p> <p>When the SLEEP instruction is executed in subactive mode:</p> <p>0: Shifts directly to watch mode or high-speed mode</p> <p>1: Shifts to subsleep mode or watch mode</p> <p>When watch mode is cancelled:</p> <p>0: Shifts to high-speed mode</p> <p>1: Shifts to subactive mode</p>
5	NESEL	0	R/W	<p>Noise Elimination Sampling Frequency Select</p> <p>Selects the frequency by which the subclock (ϕ_{SUB}) input from the EXCL pin is sampled using the clock (ϕ) generated by the system clock pulse generator. Clear this bit to 0 when ϕ is 5 MHz or more.</p> <p>0: Sampling using $\phi/32$ clock</p> <p>1: Sampling using $\phi/4$ clock</p>
4	EXCLE	0	R/W	<p>Subclock Input Enable</p> <p>Enables/disables subclock input from the EXCL pin.</p> <p>0: Disables subclock input from the EXCL pin</p> <p>1: Enables subclock input from the EXCL pin</p>
3	—	0	R/W	<p>Reserved</p> <p>An undefined value is read from this bit. This bit should not be set to 1.</p>
2 to 0	—	All 0	R	<p>Reserved</p> <p>These bits are always read as 0 and cannot be modified.</p>

20.1.3 Module Stop Control Registers H and L (MSTPCRH, MSTPCRL)

MSTPCRH and MSTPCRL specify on-chip peripheral modules to shift to module stop mode in module units. Each module can enter module stop mode by setting the corresponding bit to 1.

- MSTPCRH

Bit	Bit Name	Initial Value	R/W	Corresponding Module
7	MSTP15	0* ¹	R/W	—
6	MSTP14	0* ¹	R/W	—
5	MSTP13	1	R/W	16-bit free-running timer (FRT)
4	MSTP12	1	R/W	8-bit timers (TMR_0, TMR_1)
3	MSTP11	1	R/W	8-bit PWM timer (PWM)
2	MSTP10	1* ²	R/W	—
1	MSTP9	1	R/W	A/D converter
0	MSTP8	1	R/W	8-bit timers (TMR_X, TMR_Y)

Notes: 1. Do not set this bit to 1.
2. Do not clear this bit to 0.

- MSTPCRL

Bit	Bit Name	Initial Value	R/W	Corresponding Module
7	MSTP7	1*	R/W	—
6	MSTP6	1	R/W	Serial communication interface_1 (SCI_1)
5	MSTP5	1*	R/W	—
4	MSTP4	1	R/W	I ² C bus interface_0 (IIC_0)
3	MSTP3	1	R/W	I ² C bus interface_1 (IIC_1)
2	MSTP2	1	R/W	Keyboard buffer controller, keyboard matrix interrupt mask register (KMIMR), keyboard matrix interrupt mask register A (KMIMRA), port 6 pull-up MOS control register (KMPCR)
1	MSTP1	1	R/W	8-bit timers (TMR_A, TMR_B)
0	MSTP0	1	R/W	Host interface (LPC), wake-up event interrupt mask register B (WUEMRB)

Note: * Do not clear this bit to 0.

20.2 Mode Transitions and LSI States

Figure 20.1 shows the enabled mode transition diagram. The mode transition from program execution state to program halt state is performed by the SLEEP instruction. The mode transition from program halt state to program execution state is performed by an interrupt. The $\overline{\text{STBY}}$ input causes a mode transition from any state to hardware standby mode. The $\overline{\text{RES}}$ input causes a mode transition from a state other than hardware standby mode to the reset state. Table 20.2 shows the LSI internal states in each operating mode.

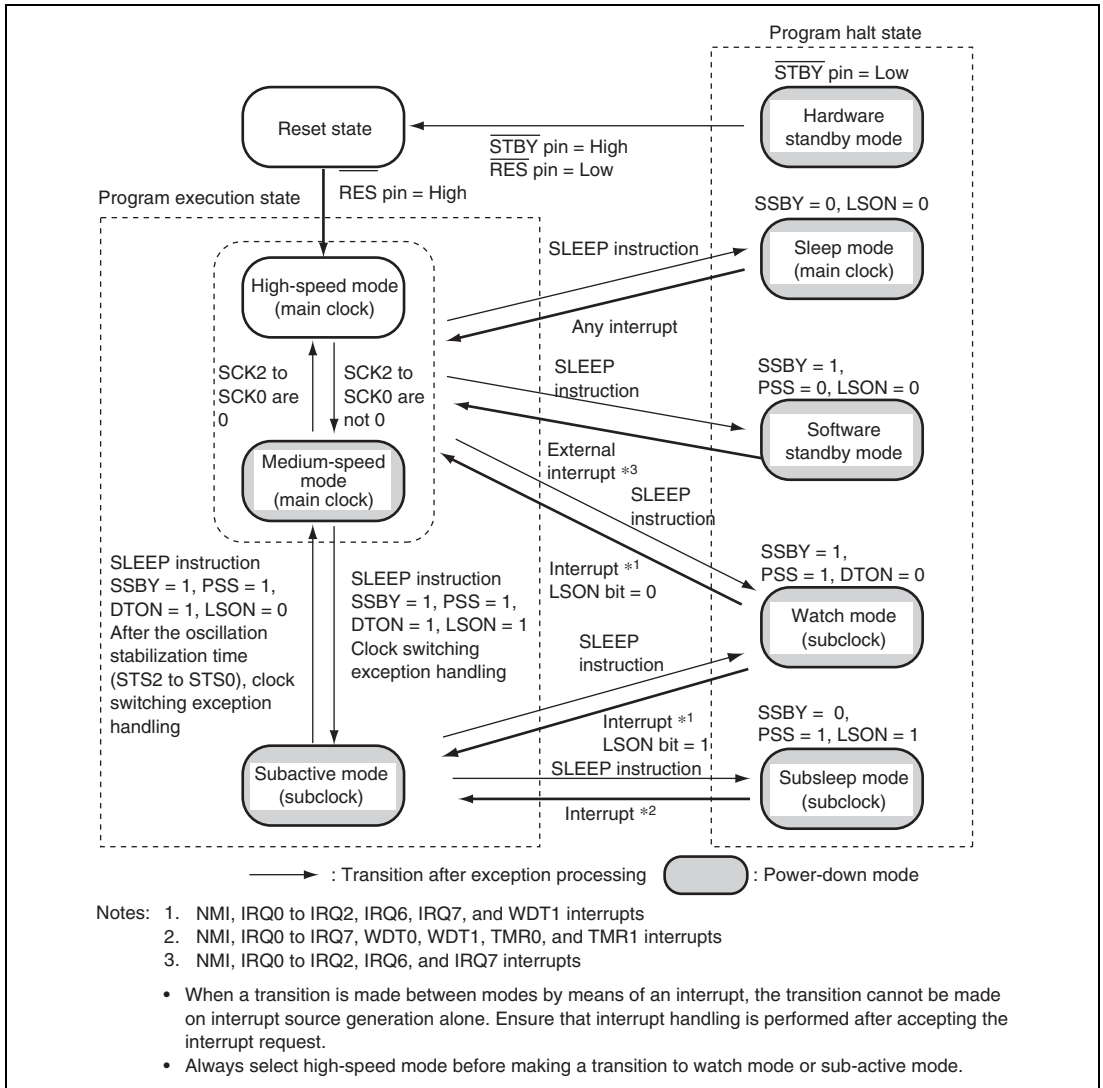

Figure 20.1 Mode Transition Diagram

Table 20.2 LSI Internal States in Each Operating Mode

Function	High-Speed	Medium-Speed	Sleep	Module Stop	Watch	Sub-Active	Sub-Sleep	Software Standby	Hardware Standby	
System clock pulse generator	Functioning	Functioning	Functioning	Functioning	Halted	Halted	Halted	Halted	Halted	
Subclock pulse generator	Functioning	Functioning	Functioning	Functioning	Functioning	Functioning	Functioning	Halted	Halted	
CPU	Instruction execution	Functioning	Medium-speed operation	Halted	Functioning	Halted	Subclock operation	Halted	Halted	Halted
	Registers			Retained		Retained		Retained	Retained	Undefined
External interrupts	NMI	Functioning	Functioning	Functioning	Functioning	Functioning	Functioning	Functioning	Functioning	Halted
	IRQ0 to IRQ7									
	KIN0 to KIN15									
	WUE0 to WUE7									
Peripheral modules	WDT_1	Functioning	Functioning	Functioning	Functioning	Subclock operation	Subclock operation	Subclock operation	Halted (retained)	Halted (reset)
	WDT_0					Halted (retained)				
	TMR_0, TMR_1				Functioning/Halted (retained)					
	FRT				Halted (retained)		Halted (retained)	Halted (retained)		
	TMR_X, TMR_Y						Halted (retained)	Halted (retained)		
	TMR_A, TMR_B									
	IIC_0									
	IIC_1									
	LPC									
	SCL_1				Functioning/Halted (reset)	Halted (reset)	Halted (reset)	Halted (reset)	Halted (reset)	
	PWM									
	Keyboard buffer controller									
	A/D									
	RAM			Functioning	Functioning	Retained	Functioning	Retained	Retained	Retained
	I/O			Functioning	Functioning	Retained	Functioning	Functioning	Retained	High impedance

Note: * "Halted (retained)" means that internal register values are retained. The internal state is "operation suspended."

"Halted (reset)" means that internal register values and internal states are initialized. In module stop mode, only modules for which a stop setting has been made are halted (reset or retained).

20.3 Medium-Speed Mode

The CPU makes a transition to medium-speed mode as soon as the current bus cycle ends according to the setting of the SCK2 to SCK0 bits in SBYCR. In medium-speed mode, the CPU operates on the operating clock ($\phi/2$, $\phi/4$, $\phi/8$, $\phi/16$, or $\phi/32$). On-chip peripheral modules other than the bus masters always operate on the system clock (ϕ).

In medium-speed mode, a bus access is executed in the specified number of states with respect to the bus master operating clock. For example, if $\phi/4$ is selected as the operating clock, on-chip memory is accessed in 4 states, and internal I/O registers in 8 states.

By clearing all of bits SCK2 to SCK0 to 0, a transition is made to high-speed mode at the end of the current bus cycle.

If a SLEEP instruction is executed when the SSBY bit in SBYCR is cleared to 0, and the LSON bit in LPWRCR is cleared to 0, a transition is made to sleep mode. When sleep mode is cleared by an interrupt, medium-speed mode is restored. When the SLEEP instruction is executed with the SSBY bit set to 1, the LSON bit cleared to 0, and the PSS bit in TCSR (WDT_1) cleared to 0, operation shifts to software standby mode. When software standby mode is cleared by an external interrupt, medium-speed mode is restored.

When the $\overline{\text{RES}}$ pin is set low and medium-speed mode is cancelled, operation shifts to the reset state. The same applies in the case of a reset caused by overflow of the watchdog timer.

When the $\overline{\text{STBY}}$ pin is driven low, medium-speed mode is cancelled and a transition is made to hardware standby mode.

Figure 20.2 shows an example of medium-speed mode timing.

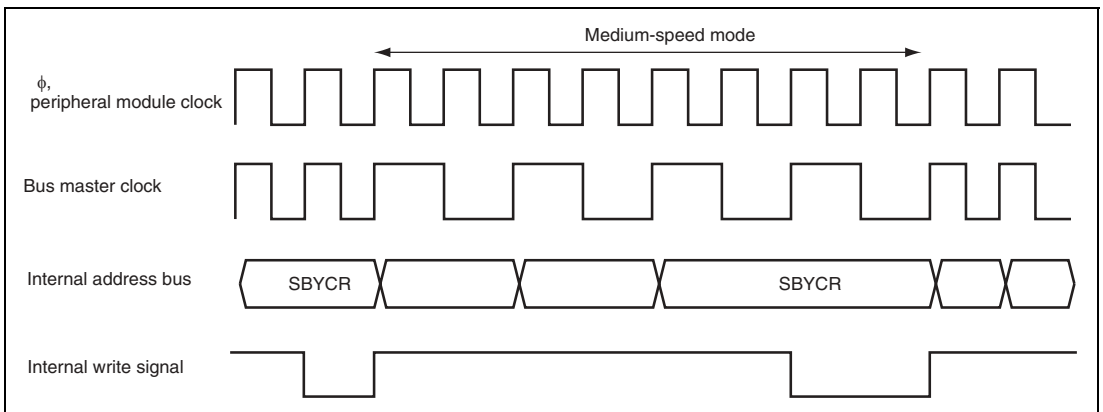

Figure 20.2 Medium-Speed Mode Timing

20.4 Sleep Mode

The CPU makes a transition to sleep mode if the SLEEP instruction is executed when the SSBY bit in SBYCR is cleared to 0 and the LSON bit in LPWRCR is cleared to 0. In sleep mode, CPU operation stops but the peripheral modules do not stop. The contents of the CPU's internal registers are retained.

Sleep mode is exited by any interrupt, the $\overline{\text{RES}}$ pin, or the $\overline{\text{STBY}}$ pin.

When an interrupt occurs, sleep mode is exited and interrupt exception handling starts. Sleep mode is not exited if the interrupt is disabled, or interrupts other than NMI are masked by the CPU.

Setting the $\overline{\text{RES}}$ pin level low cancels sleep mode and selects the reset state. After the oscillation stabilization time has passed, driving the $\overline{\text{RES}}$ pin high causes the CPU to start reset exception handling.

When the $\overline{\text{STBY}}$ pin level is driven low, sleep mode is cancelled and a transition is made to hardware standby mode.

20.5 Software Standby Mode

The CPU makes a transition to software standby mode when the SLEEP instruction is executed while the SSBY bit in SBYCR is set to 1, the LSON bit in LPWRCR is cleared to 0, and the PSS bit in TCSR (WDT_1) is cleared to 0.

In software standby mode, the CPU, on-chip peripheral modules, and clock pulse generator all stop. However, the contents of the CPU's internal registers, on-chip RAM data, I/O ports, and the states of on-chip peripheral modules other than the SCI and PWM, are retained as long as the prescribed voltage is supplied.

Software standby mode is cleared by an external interrupt (NMI, IRQ0 to IRQ2, IRQ6, or IRQ7), the $\overline{\text{RES}}$ pin input, or $\overline{\text{STBY}}$ pin input.

When an external interrupt request signal is input, system clock oscillation starts, and after the elapse of the time set in bits STS2 to STS0 in SBYCR, software standby mode is cleared, and interrupt exception handling is started. When clearing software standby mode with an IRQ0 to IRQ2, IRQ6, or IRQ7 interrupt, set the corresponding enable bit to 1 and ensure that no interrupt with a higher priority than interrupts IRQ0 to IRQ2, IRQ6, and IRQ7 is generated. Software standby mode cannot be cleared if an interrupt enable bit corresponding to an IRQ0 to IRQ2, IRQ6, or IRQ7 interrupt is cleared to 0 or if the interrupt has been masked on the CPU side.

When the $\overline{\text{RES}}$ pin is driven low, system clock oscillation is started. At the same time as system clock oscillation starts, the system clock is supplied to the entire LSI. Note that the $\overline{\text{RES}}$ pin must be held low until clock oscillation stabilizes. When the $\overline{\text{RES}}$ pin goes high after clock oscillation stabilizes, the CPU begins reset exception handling.

When the $\overline{\text{STBY}}$ pin is driven low, software standby mode is cancelled and a transition is made to hardware standby mode.

Figure 20.3 shows an example in which a transition is made to software standby mode at the falling edge of the NMI pin, and software standby mode is cleared at the rising edge of the NMI pin.

In this example, an NMI interrupt is accepted with the NMIEG bit in SYSCR cleared to 0 (falling edge specification), then the NMIEG bit is set to 1 (rising edge specification), the SSBY bit is set to 1, and a SLEEP instruction is executed, causing a transition to software standby mode.

Software standby mode is then cleared at the rising edge of the NMI pin.

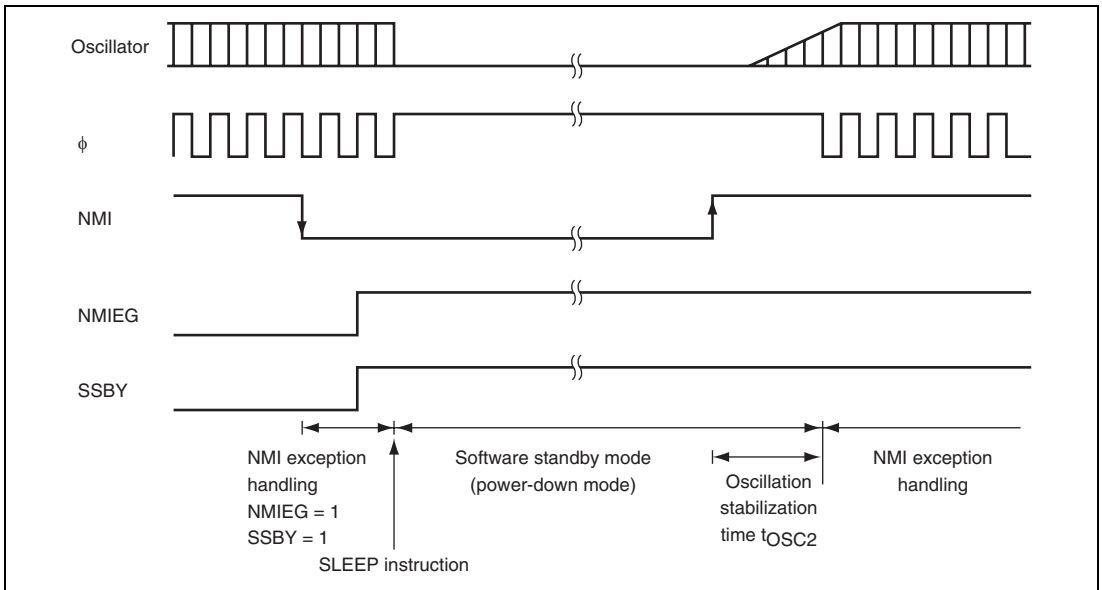

Figure 20.3 Application Example in Software Standby Mode

20.6 Hardware Standby Mode

The CPU makes a transition to hardware standby mode from any mode when the $\overline{\text{STBY}}$ pin is driven low.

In hardware standby mode, all functions enter the reset state. As long as the prescribed voltage is supplied, on-chip RAM data is retained. The I/O ports are set to the high-impedance state.

In order to retain on-chip RAM data, the RAME bit in SYSCR should be cleared to 0 before driving the $\overline{\text{STBY}}$ pin low. Do not change the state of the mode pins (MD1 and MD0) while this LSI is in hardware standby mode.

Hardware standby mode is cleared by the $\overline{\text{STBY}}$ pin input or the $\overline{\text{RES}}$ pin input.

When the $\overline{\text{STBY}}$ pin is driven high while the $\overline{\text{RES}}$ pin is low, clock oscillation is started. Ensure that the $\overline{\text{RES}}$ pin is held low until system clock oscillation stabilizes. When the $\overline{\text{RES}}$ pin is subsequently driven high after the clock oscillation stabilization time has passed, reset exception handling starts.

Figure 20.4 shows an example of hardware standby mode timing.

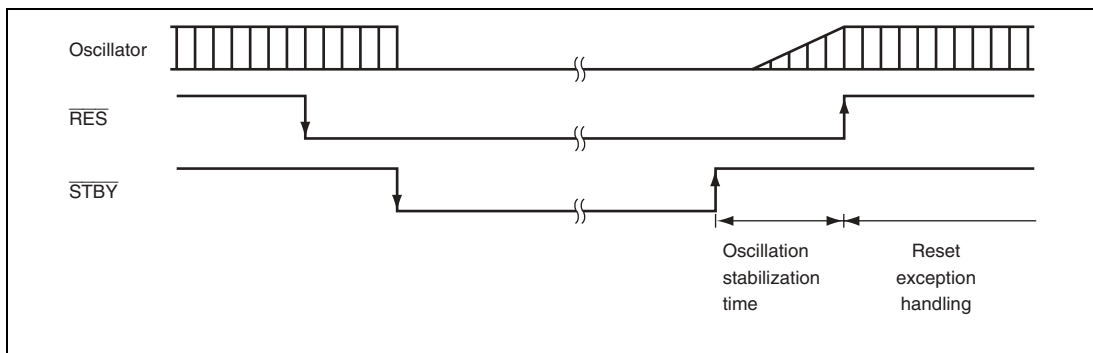

Figure 20.4 Hardware Standby Mode Timing

20.7 Watch Mode

The CPU makes a transition to watch mode when the SLEEP instruction is executed in high-speed mode or subactive mode with the SSBY bit in SBYCR set to 1, the DTON bit in LPWRCR cleared to 0, and the PSS bit in TCSR (WDT_1) set to 1.

In watch mode, the CPU is stopped and peripheral modules other than WDT_1 are also stopped. The contents of the CPU's internal registers, several on-chip peripheral module registers, and on-chip RAM data are retained and the I/O ports retain their values before transition as long as the prescribed voltage is supplied.

Watch mode is exited by an interrupt (WOVI1, NMI, IRQ0 to IRQ2, IRQ6, or IRQ7), $\overline{\text{RES}}$ pin input, or $\overline{\text{STBY}}$ pin input.

When an interrupt occurs, watch mode is exited and a transition is made to high-speed mode or medium-speed mode when the LSON bit in LPWRCR cleared to 0 or to subactive mode when the LSON bit is set to 1. When a transition is made to high-speed mode, a stable clock is supplied to the entire LSI and interrupt exception handling starts after the time set in the STS2 to STS0 bits in SBYCR has elapsed. In the case of an IRQ0 to IRQ2, IRQ6, or IRQ7 interrupt, watch mode is not exited if the corresponding enable bit has been cleared to 0. In the case of interrupts from the on-chip peripheral modules, watch mode is not exited if the interrupt enable register has been set to disable the reception of that interrupt, or the interrupt is masked by the CPU.

When the $\overline{\text{RES}}$ pin is driven low, system clock oscillation starts. Simultaneously with the start of system clock oscillation, the system clock is supplied to the entire LSI. Note that the $\overline{\text{RES}}$ pin must be held low until clock oscillation is stabilized. If the $\overline{\text{RES}}$ pin is driven high after the clock oscillation stabilization time has passed, the CPU begins reset exception handling.

If the $\overline{\text{STBY}}$ pin is driven low, the LSI enters hardware standby mode.

20.8 Subsleep Mode

The CPU makes a transition to subsleep mode when the SLEEP instruction is executed in subactive mode with the SSBY bit in SBYCR cleared to 0, the LSON bit in LPWRCR set to 1, and the PSS bit in TCSR (WDT_1) set to 1.

In subsleep mode, the CPU is stopped. Peripheral modules other than TMR_0, TMR_1, WDT_0, and WDT_1 are also stopped. The contents of the CPU's internal registers, several on-chip peripheral module registers, and on-chip RAM data are retained and the I/O ports retain their values before transition as long as the prescribed voltage is supplied.

Subsleep mode is exited by an interrupt (interrupts by on-chip peripheral modules, NMI, IRQ0 to IRQ7), the $\overline{\text{RES}}$ pin input, or the $\overline{\text{STBY}}$ pin input.

When an interrupt occurs, subsleep mode is exited and interrupt exception handling starts.

In the case of an IRQ0 to IRQ7 interrupt, subsleep mode is not exited if the corresponding enable bit has been cleared to 0. In the case of interrupts from the on-chip peripheral modules, subsleep mode is not exited if the interrupt enable register has been set to disable the reception of that interrupt, or the interrupt is masked by the CPU.

When the $\overline{\text{RES}}$ pin is driven low, system clock oscillation starts. Simultaneously with the start of system clock oscillation, the system clock is supplied to the entire LSI. Note that the $\overline{\text{RES}}$ pin must be held low until clock oscillation is stabilized. If the $\overline{\text{RES}}$ pin is driven high after the clock oscillation stabilization time has passed, the CPU begins reset exception handling.

If the $\overline{\text{STBY}}$ pin is driven low, the LSI enters hardware standby mode.

20.9 Subactive Mode

The CPU makes a transition to subactive mode when the SLEEP instruction is executed in high-speed mode with the SSBY bit in SBYCR set to 1, the DTON bit and LSON bit in LPWRCCR set to 1, and the PSS bit in TCSR (WDT_1) set to 1. When an interrupt occurs in watch mode, and if the LSON bit in LPWRCCR is 1, a direct transition is made to subactive mode. Similarly, if an interrupt occurs in subsleep mode, a transition is made to subactive mode.

In subactive mode, the CPU operates at a low speed based on the subclock and sequentially executes programs. Peripheral modules other than TMR_0, TMR_1, WDT_0, and WDT_1 are also stopped.

When operating the CPU in subactive mode, the SCK2 to SCK0 bits in SBYCR must be cleared to 0.

Subactive mode is exited by the SLEEP instruction, $\overline{\text{RES}}$ pin input, or $\overline{\text{STBY}}$ pin input.

When the SLEEP instruction is executed with the SSBY bit in SBYCR set to 1, the DTON bit in LPWRCCR cleared to 0, and the PSS bit in TCSR (WDT_1) set to 1, the CPU exits subactive mode and a transition is made to watch mode. When the SLEEP instruction is executed with the SSBY bit in SBYCR cleared to 0, the LSON bit in LPWRCCR set to 1, and the PSS bit in TCSR (WDT_1) set to 1, a transition is made to subsleep mode. When the SLEEP instruction is executed with the SSBY bit in SBYCR set to 1, the DTON bit and LSON bit in LPWRCCR set to 10, and the PSS bit in TCSR (WDT_1) set to 1, a direct transition is made to high-speed mode.

For details of direct transitions, see section 20.11, Direct Transitions.

When the $\overline{\text{RES}}$ pin is driven low, system clock oscillation starts. Simultaneously with the start of system clock oscillation, the system clock is supplied to the entire LSI. Note that the $\overline{\text{RES}}$ pin must be held low until the clock oscillation is stabilized. If the $\overline{\text{RES}}$ pin is driven high after the clock oscillation stabilization time has passed, the CPU begins reset exception handling.

If the $\overline{\text{STBY}}$ pin is driven low, the LSI enters hardware standby mode.

20.10 Module Stop Mode

Module stop mode can be individually set for each on-chip peripheral module.

When the corresponding MSTP bit in MSTPCR is set to 1, module operation stops at the end of the bus cycle and a transition is made to module stop mode. In turn, when the corresponding MSTP bit is cleared to 0, module stop mode is cancelled and the module operation resumes at the end of the bus cycle. In module stop mode, the internal states of modules other than the SCI and PWM are retained.

After the reset state is cancelled, all modules are in module stop mode.

While an on-chip peripheral module is in module stop mode, read/write access to its registers is disabled.

20.11 Direct Transitions

The CPU executes programs in three modes: high-speed, medium-speed, and subactive. When a direct transition is made from high-speed mode to subactive mode, there is no interruption of program execution. A direct transition is enabled by setting the DTON bit in LPWRCR to 1 and then executing the SLEEP instruction. After a transition, direct transition exception handling starts.

The CPU makes a transition to subactive mode when the SLEEP instruction is executed in high-speed mode with the SSBY bit in SBYCR set to 1, the LSON bit and DTON bit in LPWRCR set to 11, and the PSS bit in TSCR (WDT_1) set to 1.

To make a direct transition to high-speed mode after the time set in the STS2 to STS0 bits in SBYCR has elapsed, execute the SLEEP instruction in subactive mode with the SSBY bit in SBYCR set to 1, the LSON bit and DTON bit in LPWRCR set to 01, and the PSS bit in TSCR (WDT_1) set to 1.

20.12 Usage Notes

20.12.1 I/O Port Status

The status of the I/O ports is retained in software standby mode. Therefore, when a high level is output, the current consumption is not reduced by the amount of current to support the high level output.

20.12.2 Current Consumption when Waiting for Oscillation Stabilization

The current consumption increases during oscillation stabilization.

Section 21 List of Registers

The register list gives information on the on-chip I/O register addresses, how the register bits are configured, and the register states in each operating mode. The information is given as shown below.

1. Register Addresses (address order)

- Registers are listed from the lower allocation addresses.
- The MSB-side address is indicated for 16-bit addresses.
- Registers are classified by functional modules.
- The access size is indicated.

2. Register Bits

- Bit configurations of the registers are described in the same order as the Register Addresses (address order) above.
- Reserved bits are indicated by — in the bit name column.
- The bit number in the bit-name column indicates that the whole register is allocated as a counter or for holding data.
- 16-bit registers are indicated from the bit on the MSB side.

3. Register States in Each Operating Mode

- Register states are described in the same order as the Register Addresses (address order) above.
- The register states described here are for the basic operating modes. If there is a specific reset for an on-chip peripheral module, see the section on that on-chip peripheral module.

4. Register Select Conditions

- Register states are described in the same order as the Register Addresses (address order) above.
- For details on the register select conditions, see section 3.2.2, System Control Register (SYSCR), 3.2.3, Serial Timer Control Register (STCR), 20.1.3, Module Stop Control Registers H, L (MSTPCRH, MSTPCRL), and the register descriptions for each module.

21.1 Register Addresses (Address Order)

The data bus width indicates the numbers of bits by which the register is accessed.

The number of access states indicates the number of states based on the specified reference clock.

Register Name	Abbreviation	Number of Bits	Address	Module	Data Bus Width	Number of Access States
Timer control register_B	TCR_B	8	H'FE00	TMR_B	8	3
Timer control register_A	TCR_A	8	H'FE01	TMR_A	8	3
Timer control/status register_B	TCSR_B	8	H'FE02	TMR_B	8	3
Timer control/status register_A	TCSR_A	8	H'FE03	TMR_A	8	3
Time constant register A_B	TCORA_B	8	H'FE04	TMR_B	8	3
Time constant register A_A	TCORA_A	8	H'FE05	TMR_A	8	3
Time constant register B_B	TCORB_B	8	H'FE06	TMR_B	8	3
Time constant register B_A	TCORB_A	8	H'FE07	TMR_A	8	3
Timer counter_B	TCNT_B	8	H'FE08	TMR_B	8	3
Timer counter_A	TCNT_A	8	H'FE09	TMR_A	8	3
Timer input select register_B	TISR_B	8	H'FE0A	TMR_B	8	3
Input capture register R_A	TICRR_A	8	H'FE0C	TMR_A	8	3
Input capture register F_A	TICRF_A	8	H'FE0D	TMR_A	8	3
Timer AB control register	TCRAB	8	H'FE0E	TMR_A, TMR_B	8	3
Timer XY control register*	TCRXY	8	H'FE10	TMR_X, TMR_Y	8	3
Serial pin select register*	SPSR	8	H'FE12	SCI_1	8	3
Port G control register*	PGCTL	8	H'FE14	IIC common	8	3
Port G open drain control register	PGNOCR	8	H'FE16	PORT	8	3
Port E open drain control register	PENOCR	8	H'FE18	PORT	8	3
Port F open drain control register	PFNOCR	8	H'FE19	PORT	8	3
Port C open drain control register	PCNOCR	8	H'FE1C	PORT	8	3
Port D open drain control register	PDNOCR	8	H'FE1D	PORT	8	3
Bidirectional data register 0MW	TWR0MW	8	H'FE20	LPC	8	3
Bidirectional data register 0SW	TWR0SW	8	H'FE20	LPC	8	3

Register Name	Abbreviation	Number of Bits	Address	Module	Data Bus Width	Number of Access States
Bidirectional data register 1	TWR1	8	H'FE21	LPC	8	3
Bidirectional data register 2	TWR2	8	H'FE22	LPC	8	3
Bidirectional data register 3	TWR3	8	H'FE23	LPC	8	3
Bidirectional data register 4	TWR4	8	H'FE24	LPC	8	3
Bidirectional data register 5	TWR5	8	H'FE25	LPC	8	3
Bidirectional data register 6	TWR6	8	H'FE26	LPC	8	3
Bidirectional data register 7	TWR7	8	H'FE27	LPC	8	3
Bidirectional data register 8	TWR8	8	H'FE28	LPC	8	3
Bidirectional data register 9	TWR9	8	H'FE29	LPC	8	3
Bidirectional data register 10	TWR10	8	H'FE2A	LPC	8	3
Bidirectional data register 11	TWR11	8	H'FE2B	LPC	8	3
Bidirectional data register 12	TWR12	8	H'FE2C	LPC	8	3
Bidirectional data register 13	TWR13	8	H'FE2D	LPC	8	3
Bidirectional data register 14	TWR14	8	H'FE2E	LPC	8	3
Bidirectional data register 15	TWR15	8	H'FE2F	LPC	8	3
Input data register 3	IDR3	8	H'FE30	LPC	8	3
Output data register 3	ODR3	8	H'FE31	LPC	8	3
Status register 3	STR3	8	H'FE32	LPC	8	3
LPC channel address register H	LADR3H	8	H'FE34	LPC	8	3
LPC channel address register L	LADR3L	8	H'FE35	LPC	8	3
SERIRQ control register 0	SIRQCR0	8	H'FE36	LPC	8	3
SERIRQ control register 1	SIRQCR1	8	H'FE37	LPC	8	3
Input data register 1	IDR1	8	H'FE38	LPC	8	3
Output data register 1	ODR1	8	H'FE39	LPC	8	3
Status register 1	STR1	8	H'FE3A	LPC	8	3
Input data register 2	IDR2	8	H'FE3C	LPC	8	3
Output data register 2	ODR2	8	H'FE3D	LPC	8	3
Status register 2	STR2	8	H'FE3E	LPC	8	3
Host interface select register	HISEL	8	H'FE3F	LPC	8	3
Host interface control register 0	HICR0	8	H'FE40	LPC	8	3
Host interface control register 1	HICR1	8	H'FE41	LPC	8	3
Host interface control register 2	HICR2	8	H'FE42	LPC	8	3
Host interface control register 3	HICR3	8	H'FE43	LPC	8	3

Register Name	Abbreviation	Number of Bits	Address	Module	Data Bus Width	Number of Access States
Wakeup event interrupt mask register B	WUEMRB	8	H'FE44	INT	8	3
Port G output data register	PGODR	8	H'FE46	PORT	8	3
Port G input data register	PGPIN	8	H'FE47 (read)	PORT	8	3
Port G data direction register	PGDDR	8	H'FE47 (write)	PORT	8	3
Port E output data register	PEODR	8	H'FE48	PORT	8	3
Port F output data register	PFODR	8	H'FE49	PORT	8	3
Port E input data register	PEPIN	8	H'FE4A (read)	PORT	8	3
Port E data direction register	PEDDR	8	H'FE4A (write)	PORT	8	3
Port F input data register	PFPIN	8	H'FE4B (read)	PORT	8	3
Port F data direction register	PFDDR	8	H'FE4B (write)	PORT	8	3
Port C output data register	PCODR	8	H'FE4C	PORT	8	3
Port D output data register	PDODR	8	H'FE4D	PORT	8	3
Port C input data register	PCPIN	8	H'FE4E (read)	PORT	8	3
Port C data direction register	PCDDR	8	H'FE4E (write)	PORT	8	3
Port D input data register	PDPIN	8	H'FE4F (read)	PORT	8	3
Port D data direction register	PDDDR	8	H'FE4F (write)	PORT	8	3
I ² C bus extended control register_0	ICXR_0	8	H'FED4	IIC_0	8	2
I ² C bus extended control register_1	ICXR_1	8	H'FED5	IIC_1	8	2
Keyboard control register H_0	KBCRH_0	8	H'FED8	Keyboard buffer controller_0	8	2
Keyboard control register L_0	KBCRL_0	8	H'FED9	Keyboard buffer controller_0	8	2
Keyboard data buffer register_0	KBBR_0	8	H'FEDA	Keyboard buffer controller_0	8	2

Register Name	Abbreviation	Number of Bits	Address	Module	Data Bus Width	Number of Access States
Keyboard control register H_1	KBCRH_1	8	H'FEDC	Keyboard buffer controller_1	8	2
Keyboard control register L_1	KBCRL_1	8	H'FEDD	Keyboard buffer controller_1	8	2
Keyboard data buffer register_1	KBBR_1	8	H'FEDE	Keyboard buffer controller_1	8	2
Keyboard control register H_2	KBCRH_2	8	H'FEE0	Keyboard buffer controller_2	8	2
Keyboard control register L_2	KBCRL_2	8	H'FEE1	Keyboard buffer controller_2	8	2
Keyboard data buffer register_2	KBBR_2	8	H'FEE2	Keyboard buffer controller_2	8	2
DDC switch register	DDCSWR	8	H'FEE6	IIC common	8	2
Interrupt control register A	ICRA	8	H'FEE8	INT	8	2
Interrupt control register B	ICRB	8	H'FEE9	INT	8	2
Interrupt control register C	ICRC	8	H'FEEA	INT	8	2
IRQ status register	ISR	8	H'FEEB	INT	8	2
IRQ sense control register H	ISCRH	8	H'FEEC	INT	8	2
IRQ sense control register L	ISCR_L	8	H'FEED	INT	8	2
Address break control register	ABRKCR	8	H'FEF4	INT	8	2
Break address register A	BARA	8	H'FEF5	INT	8	2
Break address register B	BARB	8	H'FEF6	INT	8	2
Break address register C	BARC	8	H'FEF7	INT	8	2
Flash memory control register 1	FLMCR1	8	H'FF80	FLASH	8	2
Flash memory control register 2	FLMCR2	8	H'FF81	FLASH	8	2
Peripheral clock select register	PCSR	8	H'FF82	PWM	8	2
Erase block register 1	EBR1	8	H'FF82	FLASH	8	2
System control register 2	SYSCR2	8	H'FF83	SYSTEM	8	2
Erase block register 2	EBR2	8	H'FF83	FLASH	8	2
Standby control register	SBYCR	8	H'FF84	SYSTEM	8	2

Register Name	Abbreviation	Number of Bits	Address	Module	Data Bus Width	Number of Access States
Low power control register	LPWRCR	8	H'FF85	SYSTEM	8	2
Module stop control register H	MSTPCRH	8	H'FF86	SYSTEM	8	2
Module stop control register L	MSTPCRL	8	H'FF87	SYSTEM	8	2
Serial mode register_1	SMR_1	8	H'FF88	SCI_1	8	2
I ² C bus control register_1	ICCR_1	8	H'FF88	IIC_1	8	2
Bit rate register_1	BRR_1	8	H'FF89	SCI_1	8	2
I ² C bus status register_1	ICSR_1	8	H'FF89	IIC_1	8	2
Serial control register_1	SCR_1	8	H'FF8A	SCI_1	8	2
Transmit data register_1	TDR_1	8	H'FF8B	SCI_1	8	2
Serial status register_1	SSR_1	8	H'FF8C	SCI_1	8	2
Receive data register_1	RDR_1	8	H'FF8D	SCI_1	8	2
Smart card mode register_1	SCMR_1	8	H'FF8E	SCI_1	8	2
I ² C bus data register_1	ICDR_1	8	H'FF8E	IIC_1	8	2
Second slave address register_1	SARX_1	8	H'FF8E	IIC_1	8	2
I ² C bus mode register_1	ICMR_1	8	H'FF8F	IIC_1	8	2
Slave address register_1	SAR_1	8	H'FF8F	IIC_1	8	2
Timer interrupt enable register	TIER	8	H'FF90	FRT	8	2
Timer control/status register	TCSR	8	H'FF91	FRT	8	2
Free running counter H	FRCH	8	H'FF92	FRT	8	2
Free running counter L	FRCL	8	H'FF93	FRT	8	2
Output control register AH	OCRAH	8	H'FF94	FRT	8	2
Output control register BH	OCRBH	8	H'FF94	FRT	8	2
Output control register AL	OCRAL	8	H'FF95	FRT	8	2
Output control register BL	OCRBL	8	H'FF95	FRT	8	2
Timer control register	TCR	8	H'FF96	FRT	8	2
Timer output compare control register	TOCR	8	H'FF97	FRT	8	2
Input capture register AH	ICRAH	8	H'FF98	FRT	8	2
Output control register ARH	OCRARH	8	H'FF98	FRT	8	2
Input capture register AL	ICRAL	8	H'FF99	FRT	8	2
Output control register ARL	OCRARL	8	H'FF99	FRT	8	2
Input capture register BH	ICRBH	8	H'FF9A	FRT	8	2
Output control register AFH	OCRAFH	8	H'FF9A	FRT	8	2
Input capture register BL	ICRBL	8	H'FF9B	FRT	8	2

Register Name	Abbreviation	Number of Bits	Address	Module	Data Bus Width	Number of Access States
Output control register AFL	OCRAFL	8	H'FF9B	FRT	8	2
Input capture register CH	ICRCH	8	H'FF9C	FRT	8	2
Output compare register DMH	OCRDMH	8	H'FF9C	FRT	8	2
Input capture register CL	ICRCL	8	H'FF9D	FRT	8	2
Output compare register DML	OCRDML	8	H'FF9D	FRT	8	2
Input capture register DH	ICRDH	8	H'FF9E	FRT	8	2
Input capture register DL	ICRDL	8	H'FF9F	FRT	8	2
Timer control/status register_0	TCSR_0	8	H'FFA8	WDT_0	8	2
Timer counter_0	TCNT_0	8	H'FFA8 (write)	WDT_0	8	2
Timer counter_0	TCNT_0	8	H'FFA9 (read)	WDT_0	8	2
Port A output data register	PAODR	8	H'FFAA	PORT	8	2
Port A input data register	PAPIN	8	H'FFAB	PORT	8	2
Port A data direction register	PADDR	8	H'FFAB	PORT	8	2
Port 1 pull-up MOS control register	P1PCR	8	H'FFAC	PORT	8	2
Port 2 pull-up MOS control register	P2PCR	8	H'FFAD	PORT	8	2
Port 3 pull-up MOS control register	P3PCR	8	H'FFAE	PORT	8	2
Port 1 data direction register	P1DDR	8	H'FFB0	PORT	8	2
Port 2 data direction register	P2DDR	8	H'FFB1	PORT	8	2
Port 1 data register	P1DR	8	H'FFB2	PORT	8	2
Port 2 data register	P2DR	8	H'FFB3	PORT	8	2
Port 3 data direction register	P3DDR	8	H'FFB4	PORT	8	2
Port 4 data direction register	P4DDR	8	H'FFB5	PORT	8	2
Port 3 data register	P3DR	8	H'FFB6	PORT	8	2
Port 4 data register	P4DR	8	H'FFB7	PORT	8	2
Port 5 data direction register	P5DDR	8	H'FFB8	PORT	8	2
Port 6 data direction register	P6DDR	8	H'FFB9	PORT	8	2
Port 5 data register	P5DR	8	H'FFBA	PORT	8	2
Port 6 data register	P6DR	8	H'FFBB	PORT	8	2
Port B output data register	PBODR	8	H'FFBC	PORT	8	2
Port B input data register	PBPIN	8	H'FFBD (read)	PORT	8	2

Register Name	Abbreviation	Number of Bits	Address	Module	Data Bus Width	Number of Access States
Port 8 data direction register	P8DDR	8	H'FFBD (write)	PORT	8	2
Port 7 input data register	P7PIN	8	H'FFBE (read)	PORT	8	2
Port B data direction register	PBDDR	8	H'FFBE (write)	PORT	8	2
Port 8 data register	P8DR	8	H'FFBF	PORT	8	2
Port 9 data direction register	P9DDR	8	H'FFC0	PORT	8	2
Port 9 data register	P9DR	8	H'FFC1	PORT	8	2
Interrupt enable register	IER	8	H'FFC2	INT	8	2
Serial timer control register	STCR	8	H'FFC3	SYSTEM	8	2
System control register	SYSCR	8	H'FFC4	SYSTEM	8	2
Mode control register	MDCR	8	H'FFC5	SYSTEM	8	2
Bus control register	BCR	8	H'FFC6	BSC	8	2
Wait state control register	WSCR	8	H'FFC7	BSC	8	2
Timer control register_0	TCR_0	8	H'FFC8	TMR_0	8	2
Timer control register_1	TCR_1	8	H'FFC9	TMR_1	8	2
Timer control/status register_0	TCSR_0	8	H'FFCA	TMR_0	8	2
Timer control/status register_1	TCSR_1	8	H'FFCB	TMR_1	16	2
Time constant register A_0	TCORA_0	8	H'FFCC	TMR_0	16	2
Time constant register A_1	TCORA_1	8	H'FFCD	TMR_1	16	2
Time constant register B_0	TCORB_0	8	H'FFCE	TMR_0	16	2
Time constant register B_1	TCORB_1	8	H'FFCF	TMR_1	16	2
Timer counter_0	TCNT_0	8	H'FFD0	TMR_0	16	2
Timer counter_1	TCNT_1	8	H'FFD1	TMR_1	16	2
PWM output enable register A	PWOERA	8	H'FFD3	PWM	8	2
PWM data polarity register A	PWDPRA	8	H'FFD5	PWM	8	2
PWM register select	PWSL	8	H'FFD6	PWM	8	2
PWM data registers 0 to 7	PWDR0 to PWDR7	8	H'FFD7	PWM	8	2
I ² C bus control register_0	ICCR_0	8	H'FFD8	IIC_0	8	2
I ² C bus status register_0	ICSR_0	8	H'FFD9	IIC_0	8	2
I ² C bus data register_0	ICDR_0	8	H'FFDE	IIC_0	8	2
Second slave address register_0	SARX_0	8	H'FFDE	IIC_0	8	2

Register Name	Abbreviation	Number of Bits	Address	Module	Data Bus Width	Number of Access States
I ² C bus mode register_0	ICMR_0	8	H'FFDF	IIC_0	8	2
Slave address register_0	SAR_0	8	H'FFDF	IIC_0	8	2
A/D data register AH	ADDRAH	8	H'FFE0	A/D converter	8	2
A/D data register AL	ADDRAL	8	H'FFE1	A/D converter	8	2
A/D data register BH	ADDRBH	8	H'FFE2	A/D converter	8	2
A/D data register BL	ADDRBL	8	H'FFE3	A/D converter	8	2
A/D data register CH	ADDRCH	8	H'FFE4	A/D converter	8	2
A/D data register CL	ADDRCL	8	H'FFE5	A/D converter	8	2
A/D data register DH	ADDRDH	8	H'FFE6	A/D converter	8	2
A/D data register DL	ADDRDL	8	H'FFE7	A/D converter	8	2
A/D control/status register	ADCSR	8	H'FFE8	A/D converter	8	2
A/D control register	ADCR	8	H'FFE9	A/D converter	8	2
Timer control/status register_1	TCSR_1	8	H'FFEA	WDT_1	8	2
Timer counter_1	TCNT_1	8	H'FFEA (write)	WDT_1	8	2
Timer counter_1	TCNT_1	8	H'FFEB (read)	WDT_1	8	2
Timer control register_X	TCR_X	8	H'FFF0	TMR_X	16	2
Timer control register_Y	TCR_Y	8	H'FFF0	TMR_Y	16	2
Keyboard matrix interrupt register 6	KMIMR	8	H'FFF1	INT	8	2
Timer control/status register_X	TCSR_X	8	H'FFF1	TMR_X	16	2
Timer control/status register_Y	TCSR_Y	8	H'FFF1	TMR_Y	16	2
Pull-up MOS control register	KMPCR	8	H'FFF2	PORT	8	2
Input capture register R	TICRR	8	H'FFF2	TMR_X	16	2
Time constant register A_Y	TCORA_Y	8	H'FFF2	TMR_Y	16	2
Keyboard matrix interrupt register A	KMIMRA	8	H'FFF3	INT	8	2

Register Name	Abbreviation	Number of Bits	Address	Module	Data Bus Width	Number of Access States
Input capture register F	TICRF	8	H'FFF3	TMR_X	16	2
Time constant register B_Y	TCORB_Y	8	H'FFF3	TMR_Y	16	2
Timer counter_X	TCNT_X	8	H'FFF4	TMR_X	16	2
Timer counter_Y	TCNT_Y	8	H'FFF4	TMR_Y	16	2
Timer constant register C	TCORC	8	H'FFF5	TMR_X	16	2
Timer input select register	TISR	8	H'FFF5	TMR_Y	16	2
Timer constant register A_X	TCORA_X	8	H'FFF6	TMR_X	16	2
Timer constant register B_X	TCORB_X	8	H'FFF7	TMR_X	16	2
Timer connection register I	TCONRI	8	H'FFFC	TMR_X	8	2
Timer connection register S	TCONRS	8	H'FFFE	TMR_Y	8	2

Note: * The program development tool (emulator) does not support these registers.

21.2 Register Bits

Register addresses and bit names of the on-chip peripheral modules are described below.

Each line covers 8 bits, and 16-bit registers are shown as 2 lines.

Register Abbreviation	Bit 7	Bit 6	Bit 5	Bit 4	Bit 3	Bit 2	Bit 1	Bit 0	Module
TCR_B	CMIEB	CMIEA	OVIE	CCLR1	CCLR0	CKS2	CKS1	CKS0	TMR_A
TCR_A	CMIEB	CMIEA	OVIE	CCLR1	CCLR0	CKS2	CKS1	CKS0	TMR_B
TCSR_B	CMFEB	CMFEA	OVF	ICIE	OS3	OS2	OS1	OS0	
TCSR_A	CMFEB	CMFEA	OVF	ICF	OS3	OS2	OS1	OS0	
TCORA_B	Bit 7	Bit 6	Bit 5	Bit 4	Bit 3	Bit 2	Bit 1	Bit 0	
TCORA_A	Bit 7	Bit 6	Bit 5	Bit 4	Bit 3	Bit 2	Bit 1	Bit 0	
TCORB_B	Bit 7	Bit 6	Bit 5	Bit 4	Bit 3	Bit 2	Bit 1	Bit 0	
TCORB_A	Bit 7	Bit 6	Bit 5	Bit 4	Bit 3	Bit 2	Bit 1	Bit 0	
TCNT_B	Bit 7	Bit 6	Bit 5	Bit 4	Bit 3	Bit 2	Bit 1	Bit 0	
TCNT_A	Bit 7	Bit 6	Bit 5	Bit 4	Bit 3	Bit 2	Bit 1	Bit 0	
TISR_B	—	—	—	—	—	—	—	IS	
TICRR_A	Bit 7	Bit 6	Bit 5	Bit 4	Bit 3	Bit 2	Bit 1	Bit 0	
TICRF_A	Bit 7	Bit 6	Bit 5	Bit 4	Bit 3	Bit 2	Bit 1	Bit 0	
TCRAB	—	—	CKSA	CKSB	ICST	—	—	—	
TCRXY* ¹	IOSX	IOSY	CKSX	CKSY	—	—	—	—	TMR_X TMR_Y
SPSR* ¹	SPS1	—	—	—	—	—	—	—	SCL_1
PGCTL* ¹	IIC1BS	IIC1AS	—	—	IC0BS	IIC0AS	—	—	IIC common
PGNOCR	PG7NOCR	PG6NOCR	PG5NOCR	PG4NOCR	PG3NOCR	PG2NOCR	PG1NOCR	PG0NOCR	PORT
PENOCR	PE7NOCR	PE6NOCR	PE5NOCR	PE4NOCR	PE3NOCR	PE2NOCR	PE1NOCR	PE0NOCR	
PFNOCR	PF7NOCR	PF6NOCR	PF5NOCR	PF4NOCR	PF3NOCR	PF2NOCR	PF1NOCR	PF0NOCR	
PCNOCR	PC7NOCR	PC6NOCR	PC5NOCR	PC4NOCR	PC3NOCR	PC2NOCR	PC1NOCR	PC0NOCR	
PDNOCR	PD7NOCR	PD6NOCR	PD5NOCR	PD4NOCR	PD3NOCR	PD2NOCR	PD1NOCR	PD0NOCR	
TWR0MW	Bit 7	Bit 6	Bit 5	Bit 4	Bit 3	Bit 2	Bit 1	Bit 0	LPC
TWR0SW	Bit 7	Bit 6	Bit 5	Bit 4	Bit 3	Bit 2	Bit 1	Bit 0	

Register Abbreviation	Bit 7	Bit 6	Bit 5	Bit 4	Bit 3	Bit 2	Bit 1	Bit 0	Module
TWR1	Bit 7	Bit 6	Bit 5	Bit 4	Bit 3	Bit 2	Bit 1	Bit 0	LPC
TWR2	Bit 7	Bit 6	Bit 5	Bit 4	Bit 3	Bit 2	Bit 1	Bit 0	
TWR3	Bit 7	Bit 6	Bit 5	Bit 4	Bit 3	Bit 2	Bit 1	Bit 0	
TWR4	Bit 7	Bit 6	Bit 5	Bit 4	Bit 3	Bit 2	Bit 1	Bit 0	
TWR5	Bit 7	Bit 6	Bit 5	Bit 4	Bit 3	Bit 2	Bit 1	Bit 0	
TWR6	Bit 7	Bit 6	Bit 5	Bit 4	Bit 3	Bit 2	Bit 1	Bit 0	
TWR7	Bit 7	Bit 6	Bit 5	Bit 4	Bit 3	Bit 2	Bit 1	Bit 0	
TWR8	Bit 7	Bit 6	Bit 5	Bit 4	Bit 3	Bit 2	Bit 1	Bit 0	
TWR9	Bit 7	Bit 6	Bit 5	Bit 4	Bit 3	Bit 2	Bit 1	Bit 0	
TWR10	Bit 7	Bit 6	Bit 5	Bit 4	Bit 3	Bit 2	Bit 1	Bit 0	
TWR11	Bit 7	Bit 6	Bit 5	Bit 4	Bit 3	Bit 2	Bit 1	Bit 0	
TWR12	Bit 7	Bit 6	Bit 5	Bit 4	Bit 3	Bit 2	Bit 1	Bit 0	
TWR13	Bit 7	Bit 6	Bit 5	Bit 4	Bit 3	Bit 2	Bit 1	Bit 0	
TWR14	Bit 7	Bit 6	Bit 5	Bit 4	Bit 3	Bit 2	Bit 1	Bit 0	
TWR15	Bit 7	Bit 6	Bit 5	Bit 4	Bit 3	Bit 2	Bit 1	Bit 0	
IDR3	Bit 7	Bit 6	Bit 5	Bit 4	Bit 3	Bit 2	Bit 1	Bit 0	
ODR3	Bit 7	Bit 6	Bit 5	Bit 4	Bit 3	Bit 2	Bit 1	Bit 0	
STR3* ²	IBF3B	OBF3B	MWMF	SWMF	C/D ³	DBU32	IBF3A	OBF3A	
STR3* ³	DBU37	DBU36	DBU35	DBU34	C/D ³	DBU32	IBF3A	OBF3A	
LADR3H	Bit 15	Bit 14	Bit 13	Bit 12	Bit 11	Bit 10	Bit 9	Bit 8	
SIRQCR0	Q/C	SELREQ	IEDIR	SMIE3B	SMIE3A	SMIE2	IRQ12E1	IRQ1E1	
SIRQCR1	IRQ11E3	IRQ10E3	IRQ9E3	IRQ6E3	IRQ11E2	IRQ10E2	IRQ9E2	IRQ6E2	
IDR1	Bit 7	Bit 6	Bit 5	Bit 4	Bit 3	Bit 2	Bit 1	Bit 0	
ODR1	Bit 7	Bit 6	Bit 5	Bit 4	Bit 3	Bit 2	Bit 1	Bit 0	
STR1	DBU17	DBU16	DBU15	DBU14	C/D ¹	DBU12	IBF1	OBF1	
IDR2	Bit 7	Bit 6	Bit 5	Bit 4	Bit 3	Bit 2	Bit 1	Bit 0	
ODR2	Bit 7	Bit 6	Bit 5	Bit 4	Bit 3	Bit 2	Bit 1	Bit 0	
STR2	DBU27	DBU26	DBU25	DBU24	C/D ²	DBU22	IBF2	OBF2	
HISEL	SELSTR3	SELIRQ11	SELIRQ10	SELIRQ9	SELIRQ6	SELSMI	SELIRQ12	SELIRQ1	
HICR0	LPC3E	LPC2E	LPC1E	FGA20E	SDWNE	PMEE	LSMIE	LSCIE	
HICR1	LPCBSY	CLKREQ	IRQBSY	LRSTB	SDWNB	PMEB	LSMIB	LSCIB	
HICR2	GA20	LRST	SDWN	ABRT	BFIE3	IBFIE2	IBFIE1	ERRIE	
HICR3	LFRAME	CLKRUN	SERIRQ	LRESET	LPCPD	PME	LSMI	LSCI	

Register									
Abbreviation	Bit 7	Bit 6	Bit 5	Bit 4	Bit 3	Bit 2	Bit 1	Bit 0	Module
WUEMRB	WUEMR7	WUEMR6	WUEMR5	WUEMR4	WUEMR3	WUEMR2	WUEMR1	WUEMR0	INT
PGODR	PG7ODR	PG6ODR	PG5ODR	PG4ODR	PG3ODR	PG2ODR	PG1ODR	PG0ODR	PORT
PGPIN	PG7PIN	PG6PIN	PG5PIN	PG4PIN	PG3PIN	PG2PIN	PG1PIN	PG0PIN	
PGDDR	PG7DDR	PG6DDR	PG5DDR	PG4DDR	PG3DDR	PG2DDR	PG1DDR	PG0DDR	
PEODR	PE7ODR	PE6ODR	PE5ODR	PE4ODR	PE3ODR	PE2ODR	PE1ODR	PE0ODR	
PFODR	PF7ODR	PF6ODR	PF5ODR	PF4ODR	PF3ODR	PF2ODR	PF1ODR	PF0ODR	
PEPIN	PE7PIN	PE6PIN	PE5PIN	PE4PIN	PE3PIN	PE2PIN	PE1PIN	PE0PIN	
PEDDR	PE7DDR	PE6DDR	PE5DDR	PE4DDR	PE3DDR	PE2DDR	PE1DDR	PE0DDR	
PFPIN	PF7PIN	PF6PIN	PF5PIN	PF4PIN	PF3PIN	PF2PIN	PF1PIN	PF0PIN	
PFDDR	PF7DDR	PF6DDR	PF5DDR	PF4DDR	PF3DDR	PF2DDR	PF1DDR	PF0DDR	
PCODR	PC7ODR	PC6ODR	PC5ODR	PC4ODR	PC3ODR	PC2ODR	PC1ODR	PC0ODR	
PDODR	PD7ODR	PD6ODR	PD5ODR	PD4ODR	PD3ODR	PD2ODR	PD1ODR	PD0ODR	
PCPIN	PC7PIN	PC6PIN	PC5PIN	PC4PIN	PC3PIN	PC2PIN	PC1PIN	PC0PIN	
PCDDR	PC7DDR	PC6DDR	PC5DDR	PC4DDR	PC3DDR	PC2DDR	PC1DDR	PC0DDR	
PDPIN	PD7PIN	PD6PIN	PD5PIN	PD4PIN	PD3PIN	PD2PIN	PD1PIN	PD0PIN	
PDDDR	PD7DDR	PD6DDR	PD5DDR	PD4DDR	PD3DDR	PD2DDR	PD1DDR	PD0DDR	
ICXR_0	STOPIM	HNDS	ICDRF	ICDRE	ALIE	ALSL	FNC1	FNC0	IIC_0
ICXR_1	STOPIM	HNDS	ICDRF	ICDRE	ALIE	ALSL	FNC1	FNC0	IIC_1
KBCRH_0	KBIOE	KCLKI	KDI	KBFSEL	KBIE	KBF	PER	KBS	Keyboard buffer controller _0
KBCRL_0	KBE	KCLKO	KDO	—	RXCR3	RXCR2	RXCR1	RXCR0	
KBBR_0	KB7	KB6	KB5	KB4	KB3	KB2	KB1	KB0	
KBCRH_1	KBIOE	KCLKI	KDI	KBFSEL	KBIE	KBF	PER	KBS	Keyboard buffer controller _1
KBCRL_1	KBE	KCLKO	KDO	—	RXCR3	RXCR2	RXCR1	RXCR0	
KBBR_1	KB7	KB6	KB5	KB4	KB3	KB2	KB1	KB0	
KBCRH_2	KBIOE	KCLKI	KDI	KBFSEL	KBIE	KBF	PER	KBS	Keyboard buffer controller _2
KBCRL_2	KBE	KCLKO	KDO	—	RXCR3	RXCR2	RXCR1	RXCR0	
KBBR_2	KB7	KB6	KB5	KB4	KB3	KB2	KB1	KB0	
DDCSWR	—	—	—	—	CLR3	CLR2	CLR1	CLR0	IIC common

Register Abbreviation	Bit 7	Bit 6	Bit 5	Bit 4	Bit 3	Bit 2	Bit 1	Bit 0	Module
ICRA	ICRA7	ICRA6	ICRA5	ICRA4	ICRA3	ICRA2	ICRA1	ICRA0	INT
ICRB	ICRB7	ICRB6	ICRB5	ICRB4	ICRB3	ICRB2	ICRB1	ICRB0	
ICRC	ICRC7	ICRC6	ICRC5	ICRC4	ICRC3	ICRC2	ICRC1	ICRC0	
ISR	IRQ7F	IRQ6F	IRQ5F	IRQ4F	IRQ3F	IRQ2F	IRQ1F	IRQ0F	
ISCRH	IRQ7SCB	IRQ7SCA	IRQ6SCB	IRQ6SCA	IRQ5SCB	IRQ5SCA	IRQ4SCB	IRQ4SCA	
ISCLR	IRQ3SCB	IRQ3SCA	IRQ2SCB	IRQ2SCA	IRQ1SCB	IRQ1SCA	IRQ0SCB	IRQ0SCA	
ABRKCR	CMF	—	—	—	—	—	—	BIE	
BARA	A23	A22	A21	A20	A19	A18	A17	A16	
BARB	A15	A14	A13	A12	A11	A10	A9	A8	
BARC	A7	A6	A5	A4	A3	A2	A1	—	
FLMCR1	FWE	SWE	—	—	EV	PV	E	P	FLASH
FLMCR2	FLER	—	—	—	—	—	ESU	PSU	
PCSR	—	—	—	—	PWCKC	PWCKB	PWCKA	—	PWM
EBR1	—	—	—	—	—	—	—	—	FLASH
SYSCR2	—	—	—	—	—	—	—	—	SYSTEM
EBR2	EB7	EB6	EB5	EB4	EB3	EB2	EB1	EB0	FLASH
SBYCR	SSBY	STS2	STS1	STS0	—	SCK2	SCK1	SCK0	SYSTEM
LPWRCR	DTON	LSON	NESEL	EXCLE	—	—	—	—	
MSTPCRH	MSTP15	MSTP14	MSTP13	MSTP12	MSTP11	MSTP10	MSTP9	MSTP8	
MSTPCRL	MSTP7	MSTP6	MSTP5	MSTP4	MSTP3	MSTP2	MSTP1	MSTP0	
SMR_1	C/ \bar{A}	CHR	PE	O/ \bar{E}	STOP	MP	CKS1	CKS0	SCI_1
ICCR_1	ICE	IEIC	MST	TRS	ACKE	BBSY	IRIC	SCP	IIC_1
BRR_1	Bit 7	Bit 6	Bit 5	Bit 4	Bit 3	Bit 2	Bit 1	Bit 0	SCI_1
ICSR_1	ESTP	STOP	IRTR	AASX	AL	AAS	ADZ	ACKB	IIC_1
SCR_1	TIE	RIE	TE	RE	MPIE	TEIE	CKE1	CKE0	SCI_1
TDR_1	Bit 7	Bit 6	Bit 5	Bit 4	Bit 3	Bit 2	Bit 1	Bit 0	
SSR_1	TDRE	RDRF	ORER	FER	PER	TEND	MPB	MPBT	
RDR_1	Bit 7	Bit 6	Bit 5	Bit 4	Bit 3	Bit 2	Bit 1	Bit 0	
SCMR_1	—	—	—	—	SDIR	SINV	—	SMIF	
ICDR_1	ICDR7	ICDR6	ICDR5	ICDR4	ICDR3	ICDR2	ICDR1	ICDR0	IIC_1
SARX_1	SVAX6	SVAX5	SVAX4	SVAX3	SVAX2	SVAX1	SVAX0	FSX	
ICMR_1	MLS	WAIT	CKS2	CKS1	CKS0	BC2	BC1	BC0	
SAR_1	SVA6	SVA5	SVA4	SVA3	SVA2	SVA1	SVA0	FS	

Register									Module
Abbreviation	Bit 7	Bit 6	Bit 5	Bit 4	Bit 3	Bit 2	Bit 1	Bit 0	
TIER	ICIAE	ICIBE	ICICE	ICIDE	OCIAE	OCIBE	OVIE	—	FRT
TCSR	ICFA	ICFB	ICFC	ICFD	OCFA	OCFB	OVF	CCLRA	
FRCH	Bit 15	Bit 14	Bit 13	Bit 12	Bit 11	Bit 10	Bit 9	Bit 8	
FRCL	Bit 7	Bit 6	Bit 5	Bit 4	Bit 3	Bit 2	Bit 1	Bit 0	
OCRAH	Bit 15	Bit 14	Bit 13	Bit 12	Bit 11	Bit 10	Bit 9	Bit 8	
OCRBH	Bit 15	Bit 14	Bit 13	Bit 12	Bit 11	Bit 10	Bit 9	Bit 8	
OCRAL	Bit 7	Bit 6	Bit 5	Bit 4	Bit 3	Bit 2	Bit 1	Bit 0	
OCRBL	Bit 7	Bit 6	Bit 5	Bit 4	Bit 3	Bit 2	Bit 1	Bit 0	
TCR	IEDGA	IEDGB	IEDGC	IEDGD	BUFEA	BUFEB	CKS1	CKS0	
TOCR	ICRDMS	OCRAMS	ICRS	OCRS	OEA	OEB	OLVLA	OLVLB	
ICRAH	Bit 15	Bit 14	Bit 13	Bit 12	Bit 11	Bit 10	Bit 9	Bit 8	
OCRARH	Bit 15	Bit 14	Bit 13	Bit 12	Bit 11	Bit 10	Bit 9	Bit 8	
ICRAL	Bit 7	Bit 6	Bit 5	Bit 4	Bit 3	Bit 2	Bit 1	Bit 0	
OCRARL	Bit 7	Bit 6	Bit 5	Bit 4	Bit 3	Bit 2	Bit 1	Bit 0	
ICRBH	Bit 15	Bit 14	Bit 13	Bit 12	Bit 11	Bit 10	Bit 9	Bit 8	
OCRAFH	Bit 15	Bit 14	Bit 13	Bit 12	Bit 11	Bit 10	Bit 9	Bit 8	
ICRBL	Bit 7	Bit 6	Bit 5	Bit 4	Bit 3	Bit 2	Bit 1	Bit 0	
OCRAFL	Bit 7	Bit 6	Bit 5	Bit 4	Bit 3	Bit 2	Bit 1	Bit 0	
ICRCH	Bit 15	Bit 14	Bit 13	Bit 12	Bit 11	Bit 10	Bit 9	Bit 8	
OCRDMH	Bit 15	Bit 14	Bit 13	Bit 12	Bit 11	Bit 10	Bit 9	Bit 8	
ICRCL	Bit 7	Bit 6	Bit 5	Bit 4	Bit 3	Bit 2	Bit 1	Bit 0	
OCRDML	Bit 7	Bit 6	Bit 5	Bit 4	Bit 3	Bit 2	Bit 1	Bit 0	
ICRDH	Bit 15	Bit 14	Bit 13	Bit 12	Bit 11	Bit 10	Bit 9	Bit 8	
ICRDL	Bit 7	Bit 6	Bit 5	Bit 4	Bit 3	Bit 2	Bit 1	Bit 0	
TCSR_0	OVF	WT/IT	TME	—	RST/NMI	CKS2	CKS1	CKS0	WDT_0
TCNT_0	Bit 7	Bit 6	Bit 5	Bit 4	Bit 3	Bit 2	Bit 1	Bit 0	

Register Abbreviation	Bit 7	Bit 6	Bit 5	Bit 4	Bit 3	Bit 2	Bit 1	Bit 0	Module
PAODR	PA7ODR	PA6ODR	PA5ODR	PA4ODR	PA3ODR	PA2ODR	PA1ODR	PA0ODR	PORT
PAPIN	PA7PIN	PA6PIN	PA5PIN	PA4PIN	PA3PIN	PA2PIN	PA1PIN	PA0PIN	
PADDR	PA7DDR	PA6DDR	PA5DDR	PA4DDR	PA3DDR	PA2DDR	PA1DDR	PA0DDR	
P1PCR	P17PCR	P16PCR	P15PCR	P14PCR	P13PCR	P12PCR	P11PCR	P10PCR	
P2PCR	P27PCR	P26PCR	P25PCR	P24PCR	P23PCR	P22PCR	P21PCR	P20PCR	
P3PCR	P37PCR	P36PCR	P35PCR	P34PCR	P33PCR	P32PCR	P31PCR	P30PCR	
P1DDR	P17DDR	P16DDR	P15DDR	P14DDR	P13DDR	P12DDR	P11DDR	P10DDR	
P2DDR	P27DDR	P26DDR	P25DDR	P24DDR	P23DDR	P22DDR	P21DDR	P20DDR	
P1DR	P17DR	P16DR	P15DR	P14DR	P13DR	P12DR	P11DR	P10DR	
P2DR	P27DR	P26DR	P25DR	P24DR	P23DR	P22DR	P21DR	P20DR	
P3DDR	P37DDR	P36DDR	P35DDR	P34DDR	P33DDR	P32DDR	P31DDR	P30DDR	
P4DDR	P47DDR	P46DDR	P45DDR	P44DDR	P43DDR	P42DDR	P41DDR	P40DDR	
P3DR	P37DR	P36DR	P35DR	P34DR	P33DR	P32DR	P31DR	P30DR	
P4DR	P47DR	P46DR	P45DR	P44DR	P43DR	P42DR	P41DR	P40DR	
P5DDR	—	—	—	—	—	P52DDR	P51DDR	P50DDR	
P6DDR	P67DDR	P66DDR	P65DDR	P64DDR	P63DDR	P62DDR	P61DDR	P60DDR	
P5DR	—	—	—	—	—	P52DR	P51DR	P50DR	
P6DR	P67DR	P66DR	P65DR	P64DR	P63DR	P62DR	P61DR	P60DR	
PBODR	PB7ODR	PB6ODR	PB5ODR	PB4ODR	PB3ODR	PB2ODR	PB1ODR	PB0ODR	
PBPIN	PB7PIN	PB6PIN	PB5PIN	PB4PIN	PB3PIN	PB2PIN	PB1PIN	PB0PIN	
P8DDR	—	P86DDR	P85DDR	P84DDR	P83DDR	P82DDR	P81DDR	P80DDR	
P7PIN	P77PIN	P76PIN	P75PIN	P74PIN	P73PIN	P72PIN	P71PIN	P70PIN	
PBDDR	PB7DDR	PB6DDR	PB5DDR	PB4DDR	PB3DDR	PB2DDR	PB1DDR	PB0DDR	
P8DR	—	P86DR	P85DR	P84DR	P83DR	P82DR	P81DR	P80DR	
P9DDR	P97DDR	P96DDR	P95DDR	P94DDR	P93DDR	P92DDR	P91DDR	P90DDR	
P9DR	P97DR	P96DR	P95DR	P94DR	P93DR	P92DR	P91DR	P90DR	
IER	IRQ7E	IRQ6E	IRQ5E	IRQ4E	IRQ3E	IRQ2E	IRQ1E	IRQ0E	
STCR	IICS	IICX1	IICX0	IICE	FLSHE	—	ICKS1	ICKS0	
SYSCR	—	—	INTM1	INTM0	XRST	NMIEG	HIE	RAME	
MDCR	EXPE	—	—	—	—	—	MDS1	MDS0	
BCR	—	ICIS0	BRSTRM	BRSTS1	BRSTS0	—	IOS1	IOS0	
WSCR	—	—	ABW	AST	WMS1	WMS0	WC1	WC0	

Register	Bit 7	Bit 6	Bit 5	Bit 4	Bit 3	Bit 2	Bit 1	Bit 0	Module
TCR_0	CMIEB	CMIEA	OVIE	CCLR1	CCLR0	CKS2	CKS1	CKS0	TMR_0, TMR_1
TCR_1	CMIEB	CMIEA	OVIE	CCLR1	CCLR0	CKS2	CKS1	CKS0	
TCSR_0	CMFB	CMFA	OVF	ADTE	OS3	OS2	OS1	OS0	
TCSR_1	CMFB	CMFA	OVF	—	OS3	OS2	OS1	OS0	
TCORA_0	Bit 7	Bit 6	Bit 5	Bit 4	Bit 3	Bit 2	Bit 1	Bit 0	
TCORA_1	Bit 7	Bit 6	Bit 5	Bit 4	Bit 3	Bit 2	Bit 1	Bit 0	
TCORB_0	Bit 7	Bit 6	Bit 5	Bit 4	Bit 3	Bit 2	Bit 1	Bit 0	
TCORB_1	Bit 7	Bit 6	Bit 5	Bit 4	Bit 3	Bit 2	Bit 1	Bit 0	
TCNT_0	Bit 7	Bit 6	Bit 5	Bit 4	Bit 3	Bit 2	Bit 1	Bit 0	
TCNT_1	Bit 7	Bit 6	Bit 5	Bit 4	Bit 3	Bit 2	Bit 1	Bit 0	
PWOERA	OE7	OE6	OE5	OE4	OE3	OE2	OE1	OE0	PWM
PWDpra	OS7	OS6	OS5	OS4	OS3	OS2	OS1	OS0	
PWSL	PWCKE	PWCKS	—	—	RS3	RS2	RS1	RS0	
PWDR0 to PWDR7	Bit 7	Bit 6	Bit 5	Bit 4	Bit 3	Bit 2	Bit 1	Bit 0	
ICCR_0	ICE	IEIC	MST	TRS	ACKE	BBSY	IRIC	SCP	IIC_0
ICSR_0	ESTP	STOP	IRTR	AASX	AL	AAS	ADZ	ACKB	
ICDR_0	ICDR7	ICDR6	ICDR5	ICDR4	ICDR3	ICDR2	ICDR1	ICDR0	
SARX_0	SVAX6	SVAX5	SVAX4	SVAX3	SVAX2	SVAX1	SVAX0	FSX	
ICMR_0	MLS	WAIT	CKS2	CKS1	CKS0	BC2	BC1	BC0	
SAR_0	SVA6	SVA5	SVA4	SVA3	SVA2	SVA1	SVA0	FS	
ADDRAH	AD9	AD8	AD7	AD6	AD5	AD4	AD3	AD2	A/D converter
ADDRAL	AD1	AD0	—	—	—	—	—	—	
ADDRBH	AD9	AD8	AD7	AD6	AD5	AD4	AD3	AD2	
ADDRBL	AD1	AD0	—	—	—	—	—	—	
ADDRCH	AD9	AD8	AD7	AD6	AD5	AD4	AD3	AD2	
ADDRCL	AD1	AD0	—	—	—	—	—	—	
ADDRDH	AD9	AD8	AD7	AD6	AD5	AD4	AD3	AD2	
ADDRDL	AD1	AD0	—	—	—	—	—	—	
ADCSR	ADF	ADIE	ADST	SCAN	CKS	CH2	CH1	CH0	
ADCR	TRGS1	TRGS0	—	—	—	—	—	—	
TCSR_1	OVF	WT/IT	TME	PSS	RST/NMI	CKS2	CKS1	CKS0	WDT_1
TCNT_1	Bit 7	Bit 6	Bit 5	Bit 4	Bit 3	Bit 2	Bit 1	Bit 0	

Register									
Abbreviation	Bit 7	Bit 6	Bit 5	Bit 4	Bit 3	Bit 2	Bit 1	Bit 0	Module
TMR_X	CMIEB	CMIEA	OVIE	CCLR1	CCLR0	CKS2	CKS1	CKS0	TMR_X
TMR_Y	CMIEB	CMIEA	OVIE	CCLR1	CCLR0	CKS2	CKS1	CKS0	TMR_Y
KMIMR	KMIMR7	KMIMR6	KMIMR5	KMIMR4	KMIMR3	KMIMR2	KMIMR1	KMIMR0	INT
TCSR_X	CMFB	CMFA	OVF	ICF	OS3	OS2	OS1	OS0	TMR_X
TCSR_Y	CMFB	CMFA	OVF	ICIE	OS3	OS2	OS1	OS0	TMR_Y
KMPCR	KM7PCR	KM6PCR	KM5PCR	KM4PCR	KM3PCR	KM2PCR	KM1PCR	KM0PCR	PORT
TICRR	Bit 7	Bit 6	Bit 5	Bit 4	Bit 3	Bit 2	Bit 1	Bit 0	TMR_X
TCORA_Y	Bit 7	Bit 6	Bit 5	Bit 4	Bit 3	Bit 2	Bit 1	Bit 0	TMR_Y
KMIMRA	KMIMR15	KMIMR14	KMIMR13	KMIMR12	KMIMR11	KMIMR10	KMIMR9	KMIMR8	INT
TICRF	Bit 7	Bit 6	Bit 5	Bit 4	Bit 3	Bit 2	Bit 1	Bit 0	TMR_X
TCORB_Y	Bit 7	Bit 6	Bit 5	Bit 4	Bit 3	Bit 2	Bit 1	Bit 0	TMR_Y
TCNT_X	Bit 7	Bit 6	Bit 5	Bit 4	Bit 3	Bit 2	Bit 1	Bit 0	TMR_X
TCNT_Y	Bit 7	Bit 6	Bit 5	Bit 4	Bit 3	Bit 2	Bit 1	Bit 0	TMR_Y
TCORC	Bit 7	Bit 6	Bit 5	Bit 4	Bit 3	Bit 2	Bit 1	Bit 0	TMR_X
TISR	—	—	—	—	—	—	—	IS	TMR_Y
TCORA_X	Bit 7	Bit 6	Bit 5	Bit 4	Bit 3	Bit 2	Bit 1	Bit 0	TMR_X
TCORB_X	Bit 7	Bit 6	Bit 5	Bit 4	Bit 3	Bit 2	Bit 1	Bit 0	
TCONRI	—	—	—	ICST	—	—	—	—	
TCONRS	TMRX/Y	—	—	—	—	—	—	—	TMR_Y

- Notes:
1. The program development tool (emulator) does not support these registers.
 2. When TWRE = 1 or SELSTR3 = 0 in LADR3L
 3. When TWRE = 0 and SELSTR3 = 1 in LADR3L

21.3 Register States in Each Operating Mode

Register Abbreviation	Reset	High-Speed/ Medium-Speed				Sub-Active	Sub-Sleep	Module Stop	Software Standby	Hardware Standby	Module
		Speed	Watch	Sleep	Stop						
TCR_B	Initialized	—	—	—	—	—	—	—	Initialized	TMR_A	
TCR_A	Initialized	—	—	—	—	—	—	—	Initialized	TMR_B	
TCSR_B	Initialized	—	—	—	—	—	—	—	Initialized		
TCSR_A	Initialized	—	—	—	—	—	—	—	Initialized		
TCORA_B	Initialized	—	—	—	—	—	—	—	Initialized		
TCORA_A	Initialized	—	—	—	—	—	—	—	Initialized		
TCORB_B	Initialized	—	—	—	—	—	—	—	Initialized		
TCORB_A	Initialized	—	—	—	—	—	—	—	Initialized		
TCNT_B	Initialized	—	—	—	—	—	—	—	Initialized		
TCNT_A	Initialized	—	—	—	—	—	—	—	Initialized		
TISR_B	Initialized	—	—	—	—	—	—	—	Initialized		
TICRR_A	Initialized	—	—	—	—	—	—	—	Initialized		
TICRF_A	Initialized	—	—	—	—	—	—	—	Initialized		
TCRAB	Initialized	—	—	—	—	—	—	—	Initialized		
TCRXY*	Initialized	—	—	—	—	—	—	—	Initialized	TMR_X, TMR_Y	
SPSR*	Initialized	—	—	—	—	—	—	—	Initialized	SCI_1	
PGCTL*	Initialized	—	—	—	—	—	—	—	Initialized	IIC common	
PGNOCR	Initialized	—	—	—	—	—	—	—	Initialized	PORT	
PENOCR	Initialized	—	—	—	—	—	—	—	Initialized		
PFNOCR	Initialized	—	—	—	—	—	—	—	Initialized		
PCNOCR	Initialized	—	—	—	—	—	—	—	Initialized		
PDNOCR	Initialized	—	—	—	—	—	—	—	Initialized		
TWR0MW	—	—	—	—	—	—	—	—	—	LPC	
TWR0SW	—	—	—	—	—	—	—	—	—		
TWR1	—	—	—	—	—	—	—	—	—		
TWR2	—	—	—	—	—	—	—	—	—		
TWR3	—	—	—	—	—	—	—	—	—		
TWR4	—	—	—	—	—	—	—	—	—		
TWR5	—	—	—	—	—	—	—	—	—		

Register Abbrevia- tion	Reset	High-Speed/ Medium- Speed			Sub- Active	Sub-Sleep	Module Stop	Software Standby	Hardware Standby	Module
		Speed	Watch	Sleep						
TWR6	—	—	—	—	—	—	—	—	—	LPC
TWR7	—	—	—	—	—	—	—	—	—	
TWR8	—	—	—	—	—	—	—	—	—	
TWR9	—	—	—	—	—	—	—	—	—	
TWR10	—	—	—	—	—	—	—	—	—	
TWR11	—	—	—	—	—	—	—	—	—	
TWR12	—	—	—	—	—	—	—	—	—	
TWR13	—	—	—	—	—	—	—	—	—	
TWR14	—	—	—	—	—	—	—	—	—	
TWR15	—	—	—	—	—	—	—	—	—	
IDR3	—	—	—	—	—	—	—	—	—	
ODR3	—	—	—	—	—	—	—	—	—	
STR3	Initialized	—	—	—	—	—	—	—	Initialized	
LADR3H	Initialized	—	—	—	—	—	—	—	Initialized	
LADR3L	Initialized	—	—	—	—	—	—	—	Initialized	
SIRQCR0	Initialized	—	—	—	—	—	—	—	Initialized	
SIRQCR1	Initialized	—	—	—	—	—	—	—	Initialized	
IDR1	—	—	—	—	—	—	—	—	—	
ODR1	—	—	—	—	—	—	—	—	—	
STR1	Initialized	—	—	—	—	—	—	—	Initialized	
IDR2	—	—	—	—	—	—	—	—	—	
ODR2	—	—	—	—	—	—	—	—	—	
STR2	Initialized	—	—	—	—	—	—	—	Initialized	
HISEL	Initialized	—	—	—	—	—	—	—	Initialized	
HICR0	Initialized	—	—	—	—	—	—	—	Initialized	
HICR1	Initialized	—	—	—	—	—	—	—	Initialized	
HICR2	Initialized	—	—	—	—	—	—	—	Initialized	
HICR3	—	—	—	—	—	—	—	—	—	

Register Abbrevia- tion	Reset	High-Speed/ Medium- Speed			Sub- Active	Sub-Sleep	Module Stop	Software Standby	Hardware Standby	Module
		Speed	Watch	Sleep						
WUEMRB	Initialized	—	—	—	—	—	—	—	Initialized	INT
PGODR	Initialized	—	—	—	—	—	—	—	Initialized	PORT
PGPIN	—	—	—	—	—	—	—	—	—	
PGDDR	Initialized	—	—	—	—	—	—	—	Initialized	
PEODR	Initialized	—	—	—	—	—	—	—	Initialized	
PFODR	Initialized	—	—	—	—	—	—	—	Initialized	
PEPIN	—	—	—	—	—	—	—	—	—	
PEDDR	Initialized	—	—	—	—	—	—	—	Initialized	
PFPIN	—	—	—	—	—	—	—	—	—	
PFDDR	Initialized	—	—	—	—	—	—	—	Initialized	
PCODR	Initialized	—	—	—	—	—	—	—	Initialized	
PDODR	Initialized	—	—	—	—	—	—	—	Initialized	
PCPIN	—	—	—	—	—	—	—	—	—	
PCDDR	Initialized	—	—	—	—	—	—	—	Initialized	
PDPIN	—	—	—	—	—	—	—	—	—	
PDDDR	Initialized	—	—	—	—	—	—	—	Initialized	
ICXR_0	Initialized	—	—	—	—	—	—	—	Initialized	IIC_0
ICXR_1	Initialized	—	—	—	—	—	—	—	Initialized	IIC_1
KBCRH_0	Initialized	—	Initialized	—	Initialized	Initialized	Initialized	Initialized	Initialized	Keyboard buffer controller_0
KBCRL_0	Initialized	—	Initialized	—	Initialized	Initialized	Initialized	Initialized	Initialized	
KBBR_0	Initialized	—	Initialized	—	Initialized	Initialized	Initialized	Initialized	Initialized	
KBCRH_1	Initialized	—	Initialized	—	Initialized	Initialized	Initialized	Initialized	Initialized	Keyboard buffer controller_1
KBCRL_1	Initialized	—	Initialized	—	Initialized	Initialized	Initialized	Initialized	Initialized	
KBBR_1	Initialized	—	Initialized	—	Initialized	Initialized	Initialized	Initialized	Initialized	
KBCRH_2	Initialized	—	Initialized	—	Initialized	Initialized	Initialized	Initialized	Initialized	Keyboard buffer controller_2
KBCRL_2	Initialized	—	Initialized	—	Initialized	Initialized	Initialized	Initialized	Initialized	
KBBR_2	Initialized	—	Initialized	—	Initialized	Initialized	Initialized	Initialized	Initialized	
DCSWR	Initialized	—	—	—	—	—	—	—	Initialized	IIC common

Register Abbrevia- tion	Reset	High-Speed/ Medium- Speed			Sub- Active	Sub-Sleep	Module Stop	Software Standby	Hardware Standby	Module
		Speed	Watch	Sleep						
ICRA	Initialized	—	—	—	—	—	—	—	Initialized	INT
ICRB	Initialized	—	—	—	—	—	—	—	Initialized	
ICRC	Initialized	—	—	—	—	—	—	—	Initialized	
ISR	Initialized	—	—	—	—	—	—	—	Initialized	
ISCRH	Initialized	—	—	—	—	—	—	—	Initialized	
ISCR_L	Initialized	—	—	—	—	—	—	—	Initialized	
ABRKCR	Initialized	—	—	—	—	—	—	—	Initialized	
BARA	Initialized	—	—	—	—	—	—	—	Initialized	
BARB	Initialized	—	—	—	—	—	—	—	Initialized	
BARC	Initialized	—	—	—	—	—	—	—	Initialized	
FLMCR1	Initialized	—	Initialized	—	Initialized	Initialized	—	Initialized	Initialized	FLASH
FLMCR2	Initialized	—	Initialized	—	Initialized	Initialized	—	Initialized	Initialized	
PCSR	Initialized	—	—	—	—	—	—	—	Initialized	PWM
EBR1	Initialized	—	Initialized	—	Initialized	Initialized	—	Initialized	Initialized	FLASH
SYSCR2	Initialized	—	—	—	—	—	—	—	Initialized	SYSTEM
EBR2	Initialized	—	Initialized	—	Initialized	Initialized	—	Initialized	Initialized	FLASH
SBYCR	Initialized	—	—	—	—	—	—	—	Initialized	SYSTEM
LPWRCR	Initialized	—	—	—	—	—	—	—	Initialized	
MSTPCR_H	Initialized	—	—	—	—	—	—	—	Initialized	
MSTPCR_L	Initialized	—	—	—	—	—	—	—	Initialized	
SMR_1	Initialized	—	Initialized	—	Initialized	Initialized	Initialized	Initialized	Initialized	SCL_1
ICCR_1	Initialized	—	—	—	—	—	—	—	Initialized	IIC_1
BRR_1	Initialized	—	Initialized	—	Initialized	Initialized	Initialized	Initialized	Initialized	SCL_1
ICSR_1	Initialized	—	—	—	—	—	—	—	Initialized	IIC_1
SCR_1	Initialized	—	Initialized	—	Initialized	Initialized	Initialized	Initialized	Initialized	SCL_1
TDR_1	Initialized	—	Initialized	—	Initialized	Initialized	Initialized	Initialized	Initialized	
SSR_1	Initialized	—	Initialized	—	Initialized	Initialized	Initialized	Initialized	Initialized	
RDR_1	Initialized	—	Initialized	—	Initialized	Initialized	Initialized	Initialized	Initialized	
SCMR_1	Initialized	—	Initialized	—	Initialized	Initialized	Initialized	Initialized	Initialized	
ICDR_1	—	—	—	—	—	—	—	—	—	IIC_1
SARX_1	Initialized	—	—	—	—	—	—	—	Initialized	
ICMR_1	Initialized	—	—	—	—	—	—	—	Initialized	
SAR_1	Initialized	—	—	—	—	—	—	—	Initialized	

Register Abbrevia- tion	Reset	High-Speed/ Medium- Speed			Sub- Active	Sub-Sleep	Module Stop	Software Standby	Hardware Standby	Module
		Speed	Watch	Sleep						
TIER	Initialized	—	—	—	—	—	—	—	Initialized	FRT
TCSR	Initialized	—	—	—	—	—	—	—	Initialized	
FRCH	Initialized	—	—	—	—	—	—	—	Initialized	
FRCL	Initialized	—	—	—	—	—	—	—	Initialized	
OCRAH	Initialized	—	—	—	—	—	—	—	Initialized	
OCRBH	Initialized	—	—	—	—	—	—	—	Initialized	
OCRAL	Initialized	—	—	—	—	—	—	—	Initialized	
OCRBL	Initialized	—	—	—	—	—	—	—	Initialized	
TCR	Initialized	—	—	—	—	—	—	—	Initialized	
TOCR	Initialized	—	—	—	—	—	—	—	Initialized	
ICRAH	Initialized	—	—	—	—	—	—	—	Initialized	
OCRARH	Initialized	—	—	—	—	—	—	—	Initialized	
ICRAL	Initialized	—	—	—	—	—	—	—	Initialized	
OCRARL	Initialized	—	—	—	—	—	—	—	Initialized	
ICRBH	Initialized	—	—	—	—	—	—	—	Initialized	
OCRAFH	Initialized	—	—	—	—	—	—	—	Initialized	
ICRBL	Initialized	—	—	—	—	—	—	—	Initialized	
OCRAFL	Initialized	—	—	—	—	—	—	—	Initialized	
ICRCH	Initialized	—	—	—	—	—	—	—	Initialized	
OCRDMH	Initialized	—	—	—	—	—	—	—	Initialized	
ICRCL	Initialized	—	—	—	—	—	—	—	Initialized	
OCRDML	Initialized	—	—	—	—	—	—	—	Initialized	
ICRDH	Initialized	—	—	—	—	—	—	—	Initialized	
ICRDL	Initialized	—	—	—	—	—	—	—	Initialized	
TCSR_0	Initialized	—	—	—	—	—	—	—	Initialized	WDT_0
TCNT_0	Initialized	—	—	—	—	—	—	—	Initialized	

Register Abbrevia- tion	Reset	High-Speed/ Medium- Speed			Sub- Active	Sub-Sleep	Module Stop	Software Standby	Hardware Standby	Module
		Speed	Watch	Sleep						
PAODR	Initialized	—	—	—	—	—	—	—	Initialized	PORT
PAPIN	—	—	—	—	—	—	—	—	—	
PADDR	Initialized	—	—	—	—	—	—	—	Initialized	
P1PCR	Initialized	—	—	—	—	—	—	—	Initialized	
P2PCR	Initialized	—	—	—	—	—	—	—	Initialized	
P3PCR	Initialized	—	—	—	—	—	—	—	Initialized	
P1DDR	Initialized	—	—	—	—	—	—	—	Initialized	
P2DDR	Initialized	—	—	—	—	—	—	—	Initialized	
P1DR	Initialized	—	—	—	—	—	—	—	Initialized	
P2DR	Initialized	—	—	—	—	—	—	—	Initialized	
P3DDR	Initialized	—	—	—	—	—	—	—	Initialized	
P4DDR	Initialized	—	—	—	—	—	—	—	Initialized	
P3DR	Initialized	—	—	—	—	—	—	—	Initialized	
P4DR	Initialized	—	—	—	—	—	—	—	Initialized	
P5DDR	Initialized	—	—	—	—	—	—	—	Initialized	
P6DDR	Initialized	—	—	—	—	—	—	—	Initialized	
P5DR	Initialized	—	—	—	—	—	—	—	Initialized	
P6DR	Initialized	—	—	—	—	—	—	—	Initialized	
PBODR	Initialized	—	—	—	—	—	—	—	Initialized	
PBPIN	—	—	—	—	—	—	—	—	—	
P8DDR	Initialized	—	—	—	—	—	—	—	Initialized	
P7PIN	—	—	—	—	—	—	—	—	—	
PBDDR	Initialized	—	—	—	—	—	—	—	Initialized	
P8DR	Initialized	—	—	—	—	—	—	—	Initialized	
P9DDR	Initialized	—	—	—	—	—	—	—	Initialized	
P9DR	Initialized	—	—	—	—	—	—	—	Initialized	
IER	Initialized	—	—	—	—	—	—	—	Initialized	INT
STCR	Initialized	—	—	—	—	—	—	—	Initialized	SYSTEM
SYSCR	Initialized	—	—	—	—	—	—	—	Initialized	
MDCR	Initialized	—	—	—	—	—	—	—	Initialized	
BCR	Initialized	—	—	—	—	—	—	—	Initialized	BSC
WSCR	Initialized	—	—	—	—	—	—	—	Initialized	

Register Abbrevia- tion	Reset	High-Speed/ Medium- Speed				Sub- Active	Sub-Sleep	Module Stop	Software Standby	Hardware Standby	Module
		Speed	Watch	Sleep							
TCR_0	Initialized	—	—	—	—	—	—	—	Initialized	TMR_0, TMR_1	
TCR_1	Initialized	—	—	—	—	—	—	—	Initialized		
TCSR_0	Initialized	—	—	—	—	—	—	—	Initialized		
TCSR_1	Initialized	—	—	—	—	—	—	—	Initialized		
TCORA_0	Initialized	—	—	—	—	—	—	—	Initialized		
TCORA_1	Initialized	—	—	—	—	—	—	—	Initialized		
TCORB_0	Initialized	—	—	—	—	—	—	—	Initialized		
TCORB_1	Initialized	—	—	—	—	—	—	—	Initialized		
TCNT_0	Initialized	—	—	—	—	—	—	—	Initialized		
TCNT_1	Initialized	—	—	—	—	—	—	—	Initialized		
PWOERA	Initialized	—	—	—	—	—	—	—	Initialized	PWM	
PWDpra	Initialized	—	—	—	—	—	—	—	Initialized		
PWSL	Initialized	—	Initialized	—	Initialized	Initialized	Initialized	Initialized	Initialized		
PWDR0 to PWDR7	Initialized	—	Initialized	—	Initialized	Initialized	Initialized	Initialized	Initialized		
ICCR_0	Initialized	—	—	—	—	—	—	—	Initialized	IIC_0	
ICSR_0	Initialized	—	—	—	—	—	—	—	Initialized		
ICDR_0	—	—	—	—	—	—	—	—	—		
SARX_0	Initialized	—	—	—	—	—	—	—	Initialized		
ICMR_0	Initialized	—	—	—	—	—	—	—	Initialized		
SAR_0	Initialized	—	—	—	—	—	—	—	Initialized		
ADDRAH	Initialized	—	Initialized	—	Initialized	Initialized	Initialized	Initialized	Initialized	A/D converter	
ADDRAL	Initialized	—	Initialized	—	Initialized	Initialized	Initialized	Initialized	Initialized		
ADDRBH	Initialized	—	Initialized	—	Initialized	Initialized	Initialized	Initialized	Initialized		
ADDRBL	Initialized	—	Initialized	—	Initialized	Initialized	Initialized	Initialized	Initialized		
ADDRCH	Initialized	—	Initialized	—	Initialized	Initialized	Initialized	Initialized	Initialized		
ADDRCL	Initialized	—	Initialized	—	Initialized	Initialized	Initialized	Initialized	Initialized		
ADDRDH	Initialized	—	Initialized	—	Initialized	Initialized	Initialized	Initialized	Initialized		
ADDRDL	Initialized	—	Initialized	—	Initialized	Initialized	Initialized	Initialized	Initialized		
ADCSR	Initialized	—	Initialized	—	Initialized	Initialized	Initialized	Initialized	Initialized		
ADCR	Initialized	—	Initialized	—	Initialized	Initialized	Initialized	Initialized	Initialized		
TCSR_1	Initialized	—	—	—	—	—	—	—	Initialized	WDT_1	
TCNT_1	Initialized	—	—	—	—	—	—	—	Initialized		

Register Abbrevia- tion	Reset	High-Speed/ Medium- Speed			Sub- Active	Sub-Sleep	Module Stop	Software Standby	Hardware Standby	Module
		Speed	Watch	Sleep						
TCR_X	Initialized	—	—	—	—	—	—	—	Initialized	TMR_X
TCR_Y	Initialized	—	—	—	—	—	—	—	Initialized	TMR_Y
KMIMR	Initialized	—	—	—	—	—	—	—	Initialized	INT
TCSR_X	Initialized	—	—	—	—	—	—	—	Initialized	TMR_X
TCSR_Y	Initialized	—	—	—	—	—	—	—	Initialized	TMR_Y
KMPCR	Initialized	—	—	—	—	—	—	—	Initialized	PORT
TICRR	Initialized	—	—	—	—	—	—	—	Initialized	TMR_X
TCORA_Y	Initialized	—	—	—	—	—	—	—	Initialized	TMR_Y
KMIMRA	Initialized	—	—	—	—	—	—	—	Initialized	INT
TICRF	Initialized	—	—	—	—	—	—	—	Initialized	TMR_X
TCORB_Y	Initialized	—	—	—	—	—	—	—	Initialized	TMR_Y
TCNT_X	Initialized	—	—	—	—	—	—	—	Initialized	TMR_X
TCNT_Y	Initialized	—	—	—	—	—	—	—	Initialized	TMR_Y
TCORC	Initialized	—	—	—	—	—	—	—	Initialized	TMR_X
TISR	Initialized	—	—	—	—	—	—	—	Initialized	TMR_Y
TCORA_X	Initialized	—	—	—	—	—	—	—	Initialized	TMR_X
TCORB_X	Initialized	—	—	—	—	—	—	—	Initialized	
TCONRI	Initialized	—	—	—	—	—	—	—	Initialized	TMR_X
TCONRS	Initialized	—	—	—	—	—	—	—	Initialized	TMR_Y

Note: * The program development tool (emulator) does not support these registers.

21.4 Register Select Conditions

Lower Address	Register Name	Register Select Condition	Module Name
H'FE00	TCR_B	MSTP1 = 0	TMR_A, TMR_B
H'FE01	TCR_A		
H'FE02	TCSR_B		
H'FE03	TCSR_A		
H'FE04	TCORA_B		
H'FE05	TCORA_A		
H'FE06	TCORB_B		
H'FE07	TCORB_A		
H'FE08	TCNT_B		
H'FE09	TCNT_A		
H'FE0A	TISR_B		
H'FE0C	TICRR_A		
H'FE0D	TICRF_A		
H'FE0E	TCRAB		
H'FE10	TCRXY*	No condition	TMR_X, TMR_Y
H'FE12	SPSR*	No condition	SCL_1
H'FE14	PGCTL*	No condition	IIC common
H'FE16	PGNOCR	No condition	PORT
H'FE18	PENOCR		
H'FE19	PFNOCR		
H'FE1C	PCNOCR		
H'FE1D	PDNOCR		

Lower Address	Register Name	Register Select Condition	Module Name
H'FE20	TWR0MW	MSTP0 = 0	LPC
	TWR0SW		
H'FE21	TWR1		
H'FE22	TWR2		
H'FE23	TWR3		
H'FE24	TWR4		
H'FE25	TWR5		
H'FE26	TWR6		
H'FE27	TWR7		
H'FE28	TWR8		
H'FE29	TWR9		
H'FE2A	TWR10		
H'FE2B	TWR11		
H'FE2C	TWR12		
H'FE2D	TWR13		
H'FE2E	TWR14		
H'FE2F	TWR15		
H'FE30	IDR3		
H'FE31	ODR3		
H'FE32	STR3		
H'FE34	LADR3H		
H'FE35	LADR3L		
H'FE36	SIRQCR0		
H'FE37	SIRQCR1		
H'FE38	IDR1		
H'FE39	ODR1		
H'FE3A	STR1		
H'FE3C	IDR2		
H'FE3D	ODR2		
H'FE3E	STR2		
H'FE3F	HISEL		
H'FE40	HICR0		
H'FE41	HICR1		
H'FE42	HICR2		
H'FE43	HICR3		

Lower Address	Register Name	Register Select Condition	Module Name
H'FE44	WUEMRB	No condition	INT
H'FE46	PGODR	No condition	PORT
H'FE47	PGPIN (read)		
	PGDDR (write)		
H'FE48	PEODR		
H'FE49	PFODR		
H'FE4A	PEPIN (read)		
	PEDDR (write)		
H'FE4B	PFPIN (read)		
	PFDDR (write)		
H'FE4C	PCODR		
H'FE4D	PDODR		
H'FE4E	PCPIN (read)		
	PCDDR (write)		
H'FE4F	PDPIN (read)		
	PDDDR (write)		
H'FED4	ICXR_0	No condition	IIC_0
H'FED5	ICXR_1		IIC_1
H'FED8	KBCRH_0	MSTP2 = 0	Keyboard buffer controller
H'FED9	KBCRL_0		
H'FEDA	KBBR_0		
H'FEDC	KBCRH_1		
H'FEDD	KBCRL_1		
H'FEDE	KBBR_1		
H'FEE0	KBCRH_2		
H'FEE1	KBCRL_2		
H'FEE2	KBBR_2		
H'FEE6	DDCSWR	MSTP4 = 0	IIC common

Lower Address	Register Name	Register Select Condition	Module Name
H'FEE8	ICRA	No condition	INT
H'FEE9	ICRB		
H'FEEA	ICRC		
H'FEEB	ISR		
H'FEEC	ISCRH		
H'FEED	ISCR_L		
H'FEF4	ABRKCR		
H'FEF5	BARA		
H'FEF6	BARB		
H'FEF7	BARC		
H'FF80	FLMCR1	FLSHE = 1 in STCR	FLASH
H'FF81	FLMCR2		
H'FF82	PCSR	FLSHE = 0 in STCR	PWM
	EBR1	FLSHE = 1 in STCR	FLASH
H'FF83	SYSCR2	FLSHE = 0 in STCR	SYSTEM
	EBR2	FLSHE = 1 in STCR	FLASH
H'FF84	SBYCR	FLSHE = 0 in STCR	SYSTEM
H'FF85	LPWRCR		
H'FF86	MSTPCR_H		
H'FF87	MSTPCR_L		
H'FF88	ICCR_1	MSTP3 = 0, IICE = 1 in STCR	IIC_1
H'FF89	ICSR_1	MSTP3 = 0, IICE = 1 in STCR	
H'FF8E	ICDR_1	MSTP3 = 0, IICE = 1 in STCR	ICE = 1 in ICCR1
	SARX_1		ICE = 0 in ICCR1
H'FF8F	ICMR_1		ICE = 1 in ICCR1
	SAR_1		ICE = 0 in ICCR1
H'FF90	TIER	MSTP13 = 0	FRT
H'FF91	TCSR		
H'FF92	FRCH		
H'FF93	FRCL		

Lower Address	Register Name	Register Select Condition	Module Name
H'FF94	OCRAH	MSTP13 = 0	OCRS = 0 in TOCR
	OCRBH		OCRS = 1 in TOCR
H'FF95	OCRAL		OCRS = 0 in TOCR
	OCRBL		OCRS = 1 in TOCR
H'FF96	TCR		
H'FF97	TOCR		
H'FF98	ICRAH		ICRS = 0 in TOCR
	OCRARH		ICRS = 1 in TOCR
H'FF99	ICRAL		ICRS = 0 in TOCR
	OCRARL		ICRS = 1 in TOCR
H'FF9A	ICRBH		ICRS = 0 in TOCR
	OCRAFH		ICRS = 1 in TOCR
H'FF9B	ICRBL		ICRS = 0 in TOCR
	OCRAFL		ICRS = 1 in TOCR
H'FF9C	ICRCH		ICRS = 0 in TOCR
	OCRDMH		ICRS = 1 in TOCR
H'FF9D	ICRCL		ICRS = 0 in TOCR
	OCRDML		ICRS = 1 in TOCR
H'FF9E	ICRDH		
H'FF9F	ICRDL		
H'FFA8	TCSR_0	No condition	WDT_0
	TCNT_0 (write)		
H'FFA9	TCNT_0 (read)		

Lower Address	Register Name	Register Select Condition	Module Name
H'FFAA	PAODR	No condition	PORT
H'FFAB	PAPIN (read)		
	PADDR (write)		
H'FFAC	P1PCR		
H'FFAD	P2PCR		
H'FFAE	P3PCR		
H'FFB0	P1DDR		
H'FFB1	P2DDR		
H'FFB2	P1DR		
H'FFB3	P2DR		
H'FFB4	P3DDR		
H'FFB5	P4DDR		
H'FFB6	P3DR		
H'FFB7	P4DR		
H'FFB8	P5DDR		
H'FFB9	P6DDR		
H'FFBA	P5DR		
H'FFBB	P6DR		
H'FFBC	PBODR		
H'FFBD	P8DDR (write)		
	PBPIN (read)		
H'FFBE	P7PIN (read)		
	PBDDR (write)		
H'FFBF	P8DR		
H'FFC0	P9DDR		
H'FFC1	P9DR		
H'FFC2	IER	No condition	INT
H'FFC3	STCR	No condition	SYSTEM
H'FFC4	SYSCR		
H'FFC5	MDCR		
H'FFC6	BCR	No condition	BSC
H'FFC7	WSCR		

Lower Address	Register Name	Register Select Condition	Module Name
H'FFC8	TCR_0	MSTP12 = 0	TMR_0, TMR_1
H'FFC9	TCR_1		
H'FFCA	TCSR_0		
H'FFCB	TCSR_1		
H'FFCC	TCORA_0		
H'FFCD	TCORA_1		
H'FFCE	TCORB_0		
H'FFCF	TCORB_1		
H'FFD0	TCNT_0		
H'FFD1	TCNT_1		
H'FFD3	PWOERA	No condition	PWM
H'FFD5	PWDpra		
H'FFD6	PWSL	MSTP11 = 0	
H'FFD7	PWDR0 to PWDR7		
H'FFD8	ICCR_0	MSTP4 = 0, IICE = 1 in STCR	IIC_0
H'FFD9	ICSR_0		
H'FFDE	ICDR_0	MSTP4 = 0, IICE = 1 in STCR	ICE = 1 in ICCR0
	SARX_0		ICE = 0 in ICCR0
H'FFDF	ICMR_0	MSTP4 = 0, IICE = 1 in STCR	ICE = 1 in ICCR0
	SAR_0		ICE = 0 in ICCR0
H'FFE0	ADDRAH	MSTP9 = 0	A/D
H'FFE1	ADDRAL		
H'FFE2	ADDRBH		
H'FFE3	ADDRBL		
H'FFE4	ADDRCH		
H'FFE5	ADDRCL		
H'FFE6	ADDRDH		
H'FFE7	ADDRDL		
H'FFE8	ADCSR		
H'FFE9	ADCR		

Lower Address	Register Name	Register Select Condition		Module Name
H'FFEA	TCSR_1	No condition		WDT_1
	TCNT_1 (write)			
H'FFEB	TCNT_1 (read)			
H'FFF0	TCR_X	MSTP8 = 0, HIE = 0 in SYSCR	TMRX/Y = 0 in TCONRS	TMR_X
	TCR_Y		TMRX/Y = 1 in TCONRS	TMR_Y
H'FFF1	KMIMR	MSTP2 = 0, HIE = 0 in SYSCR		INT
	TCSR_X	MSTP8 = 0, HIE = 0 in SYSCR	TMRX/Y = 0 in TCONRS	TMR_X
	TCSR_Y		TMRX/Y = 1 in TCONRS	TMR_Y
H'FFF2	KMPCR	MSTP2 = 0, HIE = 1 in SYSCR		PORT
	TICRR	MSTP8 = 0, HIE = 0 in SYSCR	TMRX/Y = 0 in TCONRS	TMR_X
	TCORA_Y		TMRX/Y = 1 in TCONRS	TMR_Y
H'FFF3	KMIMRA	MSTP2 = 0, HIE = 1 in SYSCR		INT
	TICRF	MSTP8 = 0, HIE = 0 in SYSCR	TMRX/Y = 0 in TCONRS	TMR_X
	TCORB_Y		TMRX/Y = 1 in TCONRS	TMR_Y
H'FFF4	TCNT_X	MSTP8 = 0, HIE = 0 in SYSCR	TMRX/Y = 0 in TCONRS	TMR_X
	TCNT_Y		TMRX/Y = 1 in TCONRS	TMR_Y
H'FFF5	TCORC	MSTP8 = 0, HIE = 0 in SYSCR	TMRX/Y = 0 in TCONRS	TMR_X
	TISR		TMRX/Y = 1 in TCONRS	TMR_Y
H'FFF6	TCORA_X	MSTP8 = 0, HIE = 0 in SYSCR	TMRX/Y = 0 in TCONRS	TMR_X
H'FFF7	TCORB_X			
H'FFFC	TCONRI	MSTP8 = 0, HIE = 0 in SYSCR		
H'FFFE	TCONRS	MSTP8 = 0, HIE = 0 in SYSCR		TMR_Y

Note: * The program development tool (emulator) does not support these registers.

Section 22 Electrical Characteristics

22.1 Absolute Maximum Ratings

Table 22.1 lists the absolute maximum ratings.

Table 22.1 Absolute Maximum Ratings

Item	Symbol	Value	Unit
Power supply voltage	V_{CC}, V_{CL}	-0.3 to +4.3	V
I/O buffer power supply voltage	$V_{CC}B$	-0.3 to +7.0	V
Input voltage (except ports 7, A, P97, P86, P52, P42, and port G)	V_{in}	-0.3 to $V_{CC} + 0.3$	V
Input Voltage (port A)	V_{in}	-0.3 to $V_{CC}B + 0.3$	V
Input voltage (P97, P86, P52, P42 and port G)	V_{in}	-0.3 to +7.0	V
Input voltage (port 7)	V_{in}	-0.3 to $AV_{CC} + 0.3$	V
Reference supply voltage	AV_{ref}	-0.3 to $AV_{CC} + 0.3$	V
Analog power supply voltage	AV_{CC}	-0.3 to +4.3	V
Analog input voltage	V_{AN}	-0.3 to $AV_{CC} + 0.3$	V
Operating temperature	T_{opr}	-20 to +75	°C
Operating temperature (flash memory programming/erasing)	T_{opr}	-20 to +75	°C
Storage temperature	T_{stg}	-55 to +125	°C

Caution: Permanent damage to the chip may result if absolute maximum ratings are exceeded.

Ensure so that the impressed voltage does not exceed 4.3 V for pins for which the maximum rating is determined by the voltage on the V_{CC} , AV_{CC} , and V_{CL} pins, or 7.0 V for pins for which the maximum rating is determined by $V_{CC}B$.

The V_{CC} and V_{CL} pins must be connected to the Vcc power supply.

22.2 DC Characteristics

Table 22.2 lists the DC characteristics. Permitted output current values and bus drive characteristics are shown in tables 22.3 and 22.4, respectively.

Table 22.2 DC Characteristics (1)

Conditions: $V_{CC} = 3.0\text{ V to }3.6\text{ V}^{*7}$, $V_{CCB} = 3.0\text{ V to }5.5\text{ V}$, $AV_{CC}^{*1} = 3.0\text{ V to }3.6\text{ V}$,
 $AV_{ref}^{*1} = 3.0\text{ V to }AV_{CC}$, $V_{SS} = AV_{SS}^{*1} = 0\text{ V}$, $T_a = -20\text{ to }+75^\circ\text{C}$

Item	Symbol	Min.	Typ.	Max.	Unit	Test Conditions	
Schmitt trigger input voltage	P67 to P60* ² , KIN15 to $\overline{\text{KIN8}}$, $\overline{\text{IRQ2}}$ to $\overline{\text{IRQ0}}^{*3}$, $\overline{\text{IRQ5}}$ to $\overline{\text{IRQ3}}$	(1)* ⁸ V_T^-	$V_{CC} \times 0.2$	—	—	V	
		V_T^+	—	—	$V_{CC} \times 0.7$ $V_{CCB} \times 0.7$		
		$V_T^+ - V_T^-$	$V_{CC} \times 0.05$ $V_{CCB} \times 0.05$	—	—		
Input high voltage	$\overline{\text{RES}}$, $\overline{\text{STBY}}$, NMI, MD1, MD0 EXTAL PA7 to PA0* ⁷	(2) V_{IH}	$V_{CC} \times 0.9$	—	$V_{CC} + 0.3$	V	
			$V_{CC} \times 0.7$	—	$V_{CC} + 0.3$		
			$V_{CCB} \times 0.7$	—	$V_{CCB} + 0.3$		
	Port 7	(2) V_{IH}	$V_{CC} \times 0.7$	—	$AV_{CC} + 0.3$		
	P97, P86, P52, P42, and Port G		$V_{CC} \times 0.7$	—	5.5		
Input pins except (1) and (2) above		$V_{CC} \times 0.7$	—	$V_{CC} + 0.3$			
Input low voltage	$\overline{\text{RES}}$, $\overline{\text{STBY}}$, MD1, MD0 PA7 to PA0	(3) V_{IL}	-0.3	—	$V_{CC} \times 0.1$	V	
			-0.3	—	$V_{CCB} \times 0.2$	$V_{CCB} = 3.0\text{ V to }4.0\text{ V}$	
					0.8	$V_{CCB} = 4.0\text{ V to }5.5\text{ V}$	
	NMI, EXTAL, input pins except (1) and (3) above		-0.3	—	$V_{CC} \times 0.2$	$V_{CC} = 3.0\text{ V to }3.6\text{ V}$	
Output high voltage	All output pins (except P97, P86, P52, P42, and Port G) * ⁴ , * ⁵ , * ⁶	V_{OH}	$V_{CC} - 0.5$ $V_{CCB} - 0.5$	—	—	V	$I_{OH} = -200\ \mu\text{A}$
			$V_{CC} - 1.0$ $V_{CCB} - 1.0$	—	—	V	$I_{OH} = -1\text{ mA}$, ($V_{CC} = 3.0\text{ V to }3.6\text{ V}$, $V_{CCB} = 3.0\text{ V to }4.5\text{ V}$)
	P97, P86, P52, P42, and Port G* ⁴		0.5	—	—	V	$I_{OH} = -200\ \mu\text{A}$

Item		Symbol	Min.	Typ.	Max.	Unit	Test Conditions
Output low voltage	All output pins (except $\overline{\text{RESO}}$) ^{3,5}	V_{OL}	—	—	0.4	V	$I_{OL} = 1.6 \text{ mA}$
	Ports 1 to 3		—	—	1.0	V	$I_{OL} = 5 \text{ mA}$
	$\overline{\text{RESO}}$		—	—	0.4	V	$I_{OL} = 1.6 \text{ mA}$

- Notes: 1. Do not leave the AV_{CC} , AV_{ref} , and AV_{SS} pins open even if the A/D converter is not used. Even if the A/D converter is not used, apply a value in the range 2.0 V to 3.6 V to AV_{CC} and AV_{ref} pins by connection to the power supply (V_{CC}), or some other method. Ensure that $AV_{ref} \leq AV_{CC}$.
2. P67 to P60 include peripheral module inputs multiplexed on those pins.
3. $\overline{\text{IRQ2}}$ includes the $\overline{\text{ADTRG}}$ signal multiplexed on that pin.
4. P52/ExSCK1/SCL0, P97/SDA0, P86/SCK1/SCL1, P42/SDA1, and port G are NMOS push-pull outputs.
When the SCL0, SDA0, SCL1, SDA1 (ICE = 1), ExSDAA, ExSCLA, ExSDAB, or ExSCLB pin is used as an output, it is NMOS open-drain output. Therefore, an external pull-up resistor must be connected in order to output high level.
P52/ExSCK1, P97, P86/SCK1, P42 (ICE = 0), and port G high levels are driven by NMOS.
An external pull-up resistor is necessary to provide high-level output from ExSCK1 and SCK1.
5. When IICS = 0, ICE = 0, and KBIOE = 0. Low-level output when the bus drive function is selected is determined separately.
6. The port A characteristics depend on V_{CCB} , and the other pins characteristics depend on V_{CC} .
7. For flash memory programming/erasure, the applicable range is $V_{CC} = 3.0 \text{ V}$ to 3.6 V .

Table 22.2 DC Characteristics (2)

Conditions: $V_{CC} = 3.0\text{ V to }3.6\text{ V}^{*5}$, $V_{CC}B = 3.0\text{ V to }5.5\text{ V}$, $AV_{CC}^{*1} = 3.0\text{ V to }3.6\text{ V}$,
 $AV_{ref}^{*1} = 3.0\text{ V to }AV_{CC}$, $V_{SS} = AV_{SS}^{*1} = 0\text{ V}$, $T_a = -20\text{ to }+75^\circ\text{C}$

Item	Symbol	Min.	Typ.	Max.	Unit	Test Conditions
Input leakage current	RES	$ I_{in} $	—	—	10.0	μA $V_{in} = 0.5\text{ to }V_{CC} - 0.5\text{ V}$
	STBY, NMI, MD1, MD0		—	—	1.0	
	Port 7		—	—	1.0	$V_{in} = 0.5\text{ to }AV_{CC} - 0.5\text{ V}$
Three-state leakage current (off state)	Ports 1 to 6, 8, 9, A ^{*4} , and B to G	$ I_{TSI} $	—	—	1.0	μA $V_{in} = 0.5\text{ to }V_{CC} - 0.5\text{ V}$, $V_{in} = 0.5\text{ to }V_{CC}B - 0.5\text{ V}$
Input pull-up MOS current	Ports 1 to 3	$-I_p$	5	—	150	μA $V_{in} = 0\text{ V}$, $V_{CC} = 3.0\text{ V to }3.6\text{ V}$
	Ports 6 and B to F		30	—	300	$V_{CC}B = 3.0\text{ V to }5.5\text{ V}$
	Ports A ^{*4}		30	—	600	
Input capacitance	RES	(4) C_{in}	—	—	80	pF $V_{in} = 0\text{ V}$, $f = 1\text{ MHz}$, $T_a = 25^\circ\text{C}$
	NMI		—	—	50	pF
	Input pins except (4) above		—	—	10	pF
Current dissipation ^{*2}	Normal operation	I_{CC}	—	30	40	mA $f = 10\text{ MHz}$
	Sleep mode		—	20	32	mA $f = 10\text{ MHz}$
	Standby mode ^{*3}		—	1	5.0	μA $T_a \leq 50^\circ\text{C}$
			—	—	20.0	$50^\circ\text{C} < T_a$
Analog power supply current	During A/D conversion	AI_{CC}	—	1.2	2.0	mA
	Idle		—	0.01	5.0	μA $AV_{CC} = 2.0\text{ V to }3.6\text{ V}$
Reference power supply current	During A/D conversion	AI_{ref}	—	0.5	1.0	mA
	Idle		—	0.01	5.0	μA $AV_{ref} = 2.0\text{ V to }AV_{CC}$

Item	Symbol	Min.	Typ.	Max.	Unit	Test Conditions
Analog power supply voltage* ¹	AV _{CC}	3.0	—	3.6	V	Operating
		2.0	—	3.6		Idle/not used
RAM standby voltage	V _{RAM}	2.0	—	—	V	

- Notes: 1. Do not leave the AV_{CC}, AV_{ref}, and AV_{SS} pins open even if the A/D converter is not used. Even if the A/D converter is not used, apply a value in the range 2.0 V to 3.6 V to AV_{CC} and AV_{ref} pins by connection to the power supply (V_{CC}), or some other method. Ensure that AV_{ref} ≤ AV_{CC}.
2. Current dissipation values are for V_{IH} min = V_{CC} – 0.2 V, V_{CC}B – 0.2 V, and V_{IL} max = 0.2 V with all output pins unloaded and the on-chip pull-up MOSs in the off state.
3. The values are for V_{RAM} ≤ V_{CC} < 3.0 V, V_{IH} min = V_{CC} – 0.2 V, V_{CC}B – 0.2 V, and V_{IL} max = 0.2 V.
4. The port A characteristics depend on V_{CC}B, and the other pins characteristics depend on V_{CC}.
5. For flash memory programming/erasure, the applicable range is V_{CC} = 3.0 V to 3.6 V.

Table 22.2 DC Characteristics (3) When LPC Function is Used

Conditions: V_{CC} = 3.0 V to 3.6 V, V_{CC}B = 3.0 V to 5.5 V, AV_{CC}* = 3.0 V to 3.6 V, AV_{ref}* = 3.0 V to AV_{CC}, V_{SS} = AV_{SS}*¹ = 0 V, T_a = –20 to +75°C

Item		Symbol	Min.	Max.	Unit	Test Conditions
Input high voltage	P37 to P30, P83 to P80, PB1, PB0	V _{IH}	V _{CC} × 0.5	—	V	
Input low voltage	P37 to P30, P83 to P80, PB1, PB0	V _{IL}	—	V _{CC} × 0.3	V	
Output high voltage	P37, P33 to P30, P82 to P80, PB1, PB0	V _{OH}	V _{CC} × 0.9	—	V	I _{OH} = –0.5 mA
Output low voltage	P37, P33 to P30, P82 to P80, PB1, PB0	V _{OL}	—	V _{CC} × 0.1	V	I _{OL} = 1.5 mA

Note: * Do not leave the AV_{CC}, AV_{ref}, and AV_{SS} pins open even if the A/D converter is not used. Even if the A/D converter is not used, apply a value in the range 2.0 V to 3.6 V to AV_{CC} and AV_{ref} pins by connection to the power supply (V_{CC}), or some other method. Ensure that AV_{ref} ≤ AV_{CC}.

Table 22.3 Permissible Output Currents

Conditions: $V_{CC} = 3.0\text{ V to }3.6\text{ V}$, $V_{CCB} = 3.0\text{ V to }5.5\text{ V}$, $V_{SS} = 0\text{ V}$, $T_a = -20\text{ to }+75^\circ\text{C}$

Item	Symbol	Min.	Typ.	Max.	Unit	
Permissible output low current (per pin)	SCL1, SCL0, SDA1, SDA0, PS2AC to PS2CC, PS2AD to PS2CD, PA7 to PA4, ExSDAA, ExSCLA, ExSDAB, ExSCLB (bus drive function selected)	I_{OL}	—	—	10	mA
	Ports 1, 2, 3	—	—	2		
	RES0	—	—	1		
	Other output pins	—	—	1		
Permissible output low current (total)	Total of ports 1, 2, and 3	ΣI_{OL}	—	—	40	mA
	Total of all output pins, including the above	—	—	60		
Permissible output high current (per pin)	All output pins	$-I_{OH}$	—	—	2	mA
Permissible output high current (total)	Total of all output pins	$\Sigma -I_{OH}$	—	—	30	mA

- Notes: 1. To protect chip reliability, do not exceed the output current values in table 22.3.
 2. When driving a Darlington pair or LED, always insert a current-limiting resistor in the output line, as show in figures 22.1 and 22.2.

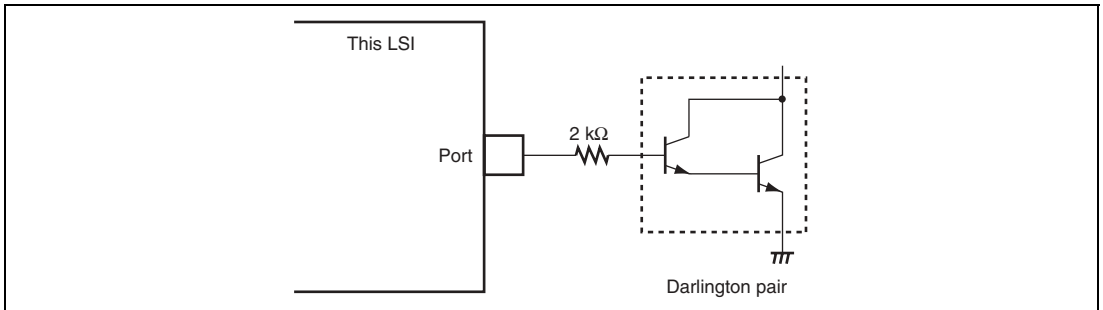

Figure 22.1 Darlington Pair Drive Circuit (Example)

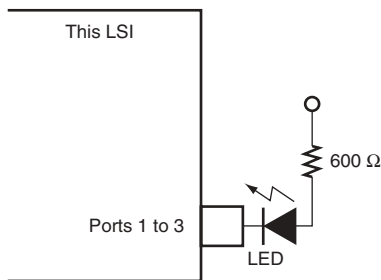

Figure 22.2 LED Drive Circuit (Example)

Table 22.4 Bus Drive Characteristics

Conditions: $V_{CC} = 3.0\text{ V to }3.6\text{ V}$, $V_{SS} = 0\text{ V}$, $T_a = -20\text{ to }+75^\circ\text{C}$

Applicable Pins: SCL1, SCL0, SDA1, SDA0 ExSDAA, ExSCLA, ExSDAB, ExSCLB (bus drive function selected)

Item	Symbol	Min.	Typ.	Max.	Unit	Test Conditions
Schmitt trigger input voltage	V_T^-	$V_{CC} \times 0.3$	—	—	V	$V_{CC} = 3.0\text{ V to }3.6\text{ V}$
	V_T^+	—	—	$V_{CC} \times 0.7$		$V_{CC} = 3.0\text{ V to }3.6\text{ V}$
	$V_T^+ - V_T^-$	$V_{CC} \times 0.05$	—	—		$V_{CC} = 3.0\text{ V to }3.6\text{ V}$
Input high voltage	V_{IH}	$V_{CC} \times 0.7$	—	5.5	V	$V_{CC} = 3.0\text{ V to }3.6\text{ V}$
Input low voltage	V_{IL}	-0.5	—	$V_{CC} \times 0.3$		$V_{CC} = 3.0\text{ V to }3.6\text{ V}$
Output low voltage	V_{OL}	—	—	0.5	V	$I_{OL} = 8\text{ mA}$
		—	—	0.4		$I_{OL} = 3\text{ mA}$
Input capacitance	C_{in}	—	—	10	pF	$V_{in} = 0\text{ V}$, $f = 1\text{ MHz}$, $T_a = 25^\circ\text{C}$
Three-state leakage current (off state)	$ I_{TSL} $	—	—	1.0	μA	$V_{in} = 0.5\text{ to }V_{CC} - 0.5\text{ V}$
SCL, SDA output fall time	t_{of}	$20 + 0.1Cb$	—	250	ns	$V_{CC} = 3.0\text{ V to }3.6\text{ V}$

Conditions: $V_{CC} = 3.0\text{ V to }3.6\text{ V}$, $V_{CCB} = 3.0\text{ V to }5.5\text{ V}$, $V_{SS} = 0\text{ V}$, $T_a = -20\text{ to }+75^\circ\text{C}$

Applicable Pins: PS2AC, PS2AD, PS2BC, PS2BD, PS2CC, PS2CD, PA7 to PA4 (bus drive function selected)

Item	Symbol	Min.	Typ.	Max.	Unit	Test Conditions
Output low voltage	V_{OL}	—	—	0.8	V	$I_{OL} = 16\text{ mA}$, $V_{CCB} = 4.5\text{ V}$ to 5.5 V
		—	—	0.5		$I_{OL} = 8\text{ mA}$
		—	—	0.4		$I_{OL} = 3\text{ mA}$

22.3 AC Characteristics

Figure 22.3 shows the test conditions for the AC characteristics.

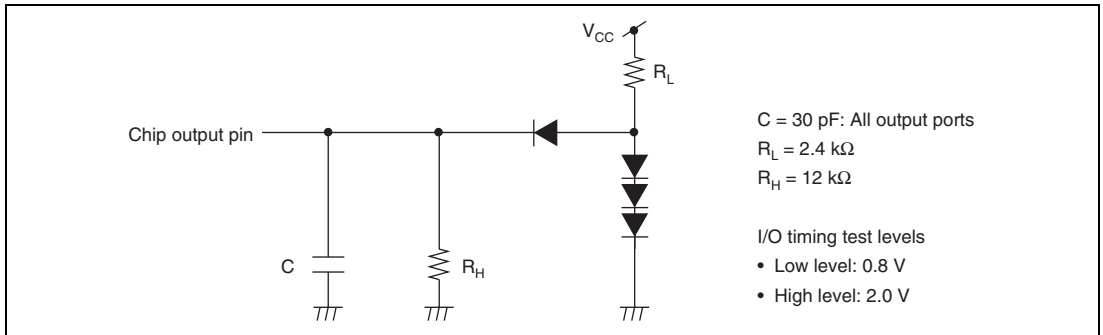

Figure 22.3 Output Load Circuit

22.3.1 Clock Timing

Table 22.5 shows the clock timing. The clock timing specified here covers clock (ϕ) output and clock pulse generator (crystal) and external clock input (EXTAL pin) oscillation settling times. For details on external clock input (EXTAL pin and EXCL pin) timing, see section 19, Clock Pulse Generator.

Table 22.5 Clock Timing

Condition: $V_{CC} = 3.0\text{ V to }3.6\text{ V}$, $V_{CCB} = 3.0\text{ V to }5.5\text{ V}$, $V_{SS} = 0\text{ V}$, $\phi = 4\text{ MHz to maximum operating frequency}$, $T_a = -20\text{ to }+75^\circ\text{C}$

Item	Symbol	Condition		Unit	Reference
		10 MHz			
		Min.	Max.		
Clock cycle time	t_{cyc}	100	250	ns	Figure 22.5
Clock high pulse width	t_{CH}	30	—	ns	
Clock low pulse width	t_{CL}	30	—	ns	
Clock rise time	t_{Cr}	—	20	ns	
Clock fall time	t_{Cf}	—	20	ns	
Oscillation settling time at reset (crystal)	t_{OSC1}	20	—	ms	Figure 22.6
Oscillation settling time in software standby (crystal)	t_{OSC2}	8	—	ms	Figure 22.7
External clock output stabilization delay time	t_{DEXT}	500	—	μs	

22.3.2 Control Signal Timing

Table 22.6 shows the control signal timing. The only external interrupts that can operate on the subclock ($\phi = 32.768$ kHz) are NMI and IRQ0, 1, 2, 6, and 7.

Table 22.6 Control Signal Timing

Conditions: $V_{CC} = 3.0$ V to 3.6 V, $V_{CCB} = 3.0$ V to 5.5 V, $V_{SS} = 0$ V, $\phi = 32.768$ kHz, 4 MHz to maximum operating frequency, $T_a = -20$ to $+75^\circ\text{C}$

Item	Symbol	Condition		Unit	Test Conditions
		10 MHz			
		Min.	Max.		
RES setup time	t_{RESS}	300	—	ns	Figure 22.8
RES pulse width	t_{RESW}	20	—	t_{cyc}	
NMI setup time (NMI)	t_{NMIS}	250	—	ns	Figure 22.9
NMI hold time (NMI)	t_{NMIH}	10	—	ns	
NMI pulse width (exiting software standby mode)	t_{NMIW}	200	—	ns	
IRQ setup time ($\overline{\text{IRQ7}}$ to $\overline{\text{IRQ0}}$)	t_{IRQS}	250	—	ns	
IRQ hold time ($\overline{\text{IRQ7}}$ to $\overline{\text{IRQ0}}$)	t_{IRQH}	10	—	ns	
IRQ pulse width ($\overline{\text{IRQ7}}$, $\overline{\text{IRQ6}}$, $\overline{\text{IRQ2}}$ to $\overline{\text{IRQ0}}$) (exiting software standby mode)	t_{IRQW}	200	—	ns	

22.3.3 Timing of On-Chip Peripheral Modules

Tables 22.7 to 22.10 show the on-chip peripheral module timing. The only on-chip peripheral modules that can operate in subclock operation ($\phi = 32.768$ kHz) are the I/O ports, external interrupts (NMI and IRQ0, 1, 2, 6, and 7), the watchdog timer, and the 8-bit timer (channels 0 and 1).

Table 22.7 Timing of On-Chip Peripheral Modules (1)

Conditions: $V_{CC} = 3.0$ V to 3.6 V, $V_{CCB} = 3.0$ V to 5.5 V, $V_{SS} = 0$ V, $\phi = 32.768$ kHz*,
4 MHz to maximum operating frequency, $T_a = -20$ to $+75^\circ\text{C}$

Item	Symbol	Condition		Unit	Test Conditions	
		Min.	Max.			
I/O ports	Output data delay time	t_{PWD}	—	100	ns	Figure 22.10
	Input data setup time	t_{PRS}	50	—		
	Input data hold time	t_{PRH}	50	—		
FRT	Timer output delay time	t_{FTOD}	—	100	ns	Figure 22.11
	Timer input setup time	t_{FTIS}	50	—		
	Timer clock input setup time	t_{FTCS}	50	—		Figure 22.12
	Timer clock pulse width	Single edge t_{FTCWH}	1.5	—	t_{cyc}	
	Both edges t_{FTCWL}	2.5	—			
TMR	Timer output delay time	t_{TMOD}	—	100	ns	Figure 22.13
	Timer reset input setup time	t_{TMRS}	50	—		Figure 22.15
	Timer clock input setup time	t_{TMCS}	50	—		Figure 22.14
	Timer clock pulse width	Single edge t_{TMCWH}	1.5	—	t_{cyc}	
	Both edges t_{TMCWL}	2.5	—			
PWM	Pulse output delay time	t_{PWOD}	—	100	ns	Figure 22.16
SCI	Input clock cycle	Asynchronous t_{Scyc}	4	—	t_{cyc}	Figure 22.17
		Synchronous	6	—		
	Input clock pulse width	t_{SCKW}	0.4	0.6	t_{Scyc}	
	Input clock rise time	t_{SCKr}	—	1.5	t_{cyc}	
	Input clock fall time	t_{SCKf}	—	1.5		

Item	Symbol	Condition		Unit	Test Conditions	
		10 MHz				
		Min.	Max.			
SCI	Transmit data delay time (synchronous)	t_{TXD}	—	100	ns	Figure 22.18
	Receive data setup time (synchronous)	t_{RXS}	100	—	ns	
	Receive data hold time (synchronous)	t_{RXH}	100	—	ns	
A/D converter	Trigger input setup time	t_{TRGS}	50	—	ns	Figure 22.19
WDT	RES0 output delay time	t_{RES0}	—	200	ns	Figure 22.20
	RES0 output pulse width	t_{RES0W}	132	—	t_{cyc}	

Note: * Only peripheral modules that can be used in subclock operation

Table 22.8 Keyboard Buffer Controller Timing

Conditions: $V_{CC} = 3.0\text{ V to }3.6\text{ V}$, $V_{CCB} = 3.0\text{ V to }5.5\text{ V}$, $V_{SS} = 0\text{ V}$, $\phi = 4\text{ MHz to maximum operating frequency}$, $T_a = -20\text{ to }+75^\circ\text{C}$

Item	Symbol	Ratings			Unit	Test Conditions	Notes
		Min.	Typ.	Max.			
KCLK, KD output fall time	t_{KBF}	20 + 0.1Cb	—	250	ns		Figure 22.21
KCLK, KD input data hold time	t_{KBIH}	150	—	—	ns		
KCLK, KD input data setup time	t_{KBIS}	150	—	—	ns		
KCLK, KD output delay time	t_{KBOD}	—	—	450	ns		
KCLK, KD capacitive load	C_b	—	—	400	pF		

Table 22.9 I²C Bus Timing

Conditions: $V_{CC} = 3.0\text{ V to }3.6\text{ V}$, $V_{SS} = 0\text{ V}$, $\phi = 5\text{ MHz}$ to maximum operating frequency,
 $T_a = -20\text{ to }+75^\circ\text{C}$

Item	Symbol	Ratings			Unit	Test Conditions	Notes
		Min.	Typ.	Max.			
SCL input cycle time	t_{SCL}	12	—	—	t_{cyc}		Figure 22.22
SCL input high pulse width	t_{SCLH}	3	—	—	t_{cyc}		
SCL input low pulse width	t_{SCLL}	5	—	—	t_{cyc}		
SCL, SDA input rise time	t_{Sr}	—	—	7.5*	t_{cyc}		
SCL, SDA input fall time	t_{Sf}	—	—	300	ns		
SCL, SDA input spike pulse elimination time	t_{SP}	—	—	1	t_{cyc}		
SDA input bus free time	t_{BUF}	5	—	—	t_{cyc}		
Start condition input hold time	t_{STAH}	3	—	—	t_{cyc}		
Retransmission start condition input setup time	t_{STAS}	3	—	—	t_{cyc}		
Stop condition input setup time	t_{STOS}	3	—	—	t_{cyc}		
Data input setup time	t_{SDAS}	0.5	—	—	t_{cyc}		
Data input hold time	t_{SDAH}	0	—	—	ns		
SCL, SDA capacitive load	C_b	—	—	400	pF		

Note: * $17.5 t_{cyc}$ can be set according to the clock selected for use by the I²C module. For details, see section 13.6, Usage Notes.

Table 22.10 LPC Module Timing

Conditions: $V_{CC} = 3.0\text{ V to }3.6\text{ V}$, $V_{SS} = 0\text{ V}$, $\phi = 4\text{ MHz}$ to maximum operating frequency,
 $T_a = -20\text{ to }+75^\circ\text{C}$

Item	Symbol	Min.	Typ.	Max.	Unit	Test Conditions	
LPC	Input clock cycle	t_{Lcyc}	30	—	—	ns	Figure 22.23
	Input clock pulse width (H)	t_{LCKH}	11	—	—		
	Input clock pulse width (L)	t_{LCKL}	11	—	—		
	Transmit signal delay time	t_{TXD}	2	—	11		
	Transmit signal floating delay time	t_{OFF}	—	—	28		
	Receive signal setup time	t_{RXS}	7	—	—		
	Receive signal hold time	t_{RXH}	0	—	—		

22.4 A/D Conversion Characteristics

Tables 22.11 list the A/D conversion characteristics.

Table 22.11 A/D Conversion Characteristics (AN5 to AN0 Input: 134/266-State Conversion)

Conditions: $V_{CC} = 3.0\text{ V to }3.6\text{ V}$, $AV_{CC} = 3.0\text{ V to }3.6\text{ V}$, $AV_{ref} = 3.0\text{ V to }AV_{CC}$,
 $V_{CCB} = 3.0\text{ V to }5.5\text{ V}$, $V_{SS} = AV_{SS} = 0\text{ V}$,
 $\phi = 4\text{ MHz}$ to maximum operating frequency, $T_a = -20\text{ to }+75^\circ\text{C}$

Item	Condition			Unit
	10 MHz			
	Min.	Typ.	Max.	
Resolution	10			bits
Conversion time	—	—	13.4	μs
Analog input capacitance	—	—	20	pF
Permissible signal-source impedance	—	—	5	k Ω
Nonlinearity error	—	—	± 7.0	LSB
Offset error	—	—	± 7.5	LSB
Full-scale error	—	—	± 7.5	LSB
Quantization error	—	—	± 0.5	LSB
Absolute accuracy	—	—	± 8.0	LSB

22.5 Flash Memory Characteristics

Table 22.12 shows the flash memory characteristics.

Table 22.12 Flash Memory Characteristics

Conditions: $V_{CC} = 3.0\text{ V to }3.6\text{ V}$, $V_{SS} = 0\text{ V}$, $T_a = -20\text{ to }+75^\circ\text{C}$

Item	Symbol	Min.	Typ.	Max.	Unit	Test Condition	
Programming time* ¹ , * ² , * ⁴	t_p	—	10	200	ms/ 128 bytes		
Erase time* ¹ , * ³ , * ⁶	t_E	—	100	1200	ms/ block		
Reprogramming count	N_{WEC}	—	—	100	times		
Programming	Wait time after SWE-bit setting* ¹	x	1	—	—	μs	
	Wait time after PSU-bit setting* ¹	y	50	—	—	μs	
	Wait time after P-bit setting* ¹ , * ⁴	z1	28	30	32	μs	$1 \leq n \leq 6$
		z2	198	200	202	μs	$7 \leq n \leq 1000$
		z3	8	10	12	μs	Additional write
	Wait time after P-bit clear* ¹	α	5	—	—	μs	
	Wait time after PSU-bit clear* ¹	β	5	—	—	μs	
	Wait time after PV-bit setting* ¹	γ	4	—	—	μs	
	Wait time after dummy write* ¹	ε	2	—	—	μs	
	Wait time after PV-bit clear* ¹	η	2	—	—	μs	
	Wait time after SWE-bit clear* ¹	θ	100	—	—	μs	
	Maximum programming count* ¹ , * ⁴ , * ⁵	N	—	—	1000	times	

Item		Symbol	Min.	Typ.	Max.	Unit	Test Conditions
Erase	Wait time after SWE-bit setting* ¹	x	1	—	—	μs	
	Wait time after ESU-bit setting* ¹	y	100	—	—	μs	
	Wait time after E-bit setting* ¹ , * ⁶	z	10	—	100	ms	
	Wait time after E-bit clear* ¹	α	10	—	—	μs	
	Wait time after ESU-bit clear* ¹	β	10	—	—	μs	
	Wait time after EV-bit setting* ¹	γ	20	—	—	μs	
	Wait time after dummy write* ¹	ε	2	—	—	μs	
	Wait time after EV-bit clear* ¹	η	4	—	—	μs	
	Wait time after SWE-bit clear* ¹	θ	100	—	—	μs	
	Maximum erase count* ¹ , * ⁶ , * ⁷	N	—	—	120	times	

- Notes: 1. Set the times according to the program/erase algorithms.
2. Programming time per 128 bytes (Shows the total period for which the P-bit in FLMCR1 is set. It does not include the programming verification time.)
3. Block erase time (Shows the total period for which the E-bit in FLMCR1 is set. It does not include the erase verification time.)
4. Maximum programming time (t_p (max))
- $$t_p \text{ (max)} = (\text{wait time after P-bit setting (z1) + (z3)})) \times 6 + \text{wait time after P-bit setting (z2)} \times ((N) - 6)$$
5. The maximum number of writes (N) should be set according to the actual set value of z1, z2 and z3 to allow programming within the maximum programming time (t_p (max)). The wait time after P-bit setting (z1, z2, and z3) should be alternated according to the number of writes (n) as follows:
- $$1 \leq n \leq 6 \quad z1 = 30\mu\text{s}, z3 = 10\mu\text{s}$$
- $$7 \leq n \leq 1000 \quad z2 = 200\mu\text{s}$$
6. Maximum erase time (t_e (max))
- $$t_e \text{ (max)} = \text{Wait time after E-bit setting (z)} \times \text{maximum erase count (N)}$$
7. The maximum number of erases (N) should be set according to the actual set value of z to allow erasing within the maximum erase time (t_e (max)).

22.6 Usage Note

The method of connecting an external capacitor is shown in figure 22.4. Connect the system power supply to the VCL pin together with the VCC pins.

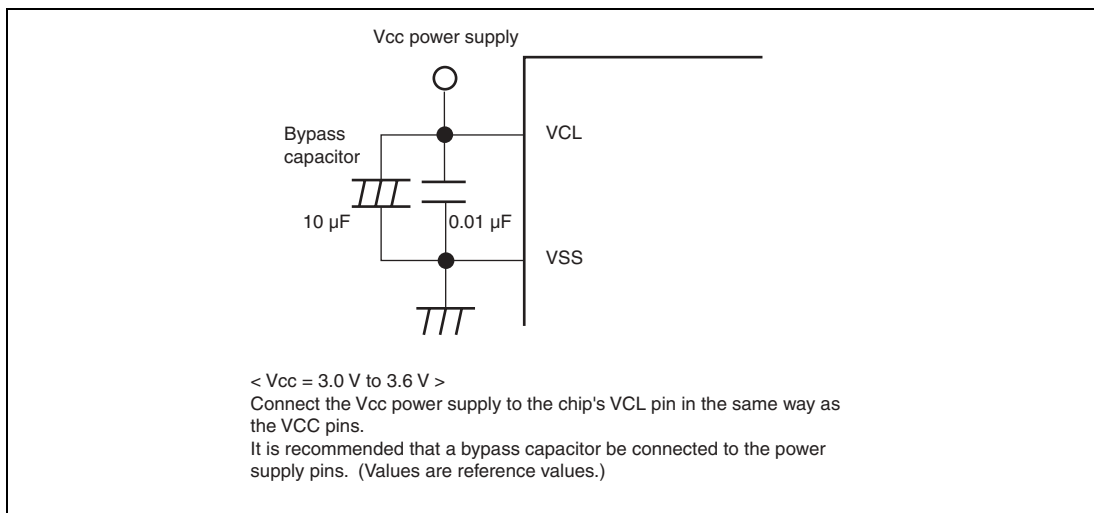

Figure 22.4 Connection of VCL Capacitor

22.7 Timing Chart

22.7.1 Clock Timing

The clock timings are shown below.

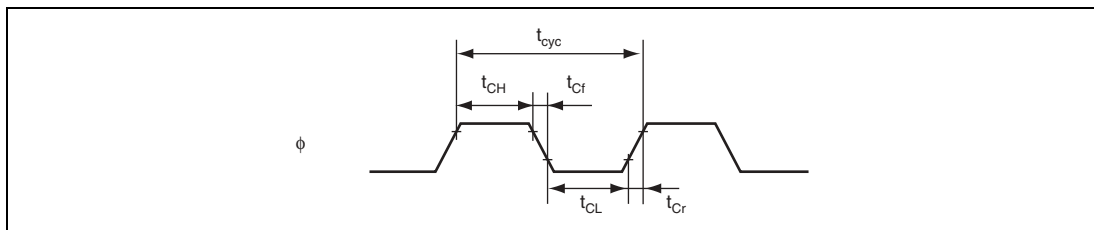

Figure 22.5 System Clock Timing

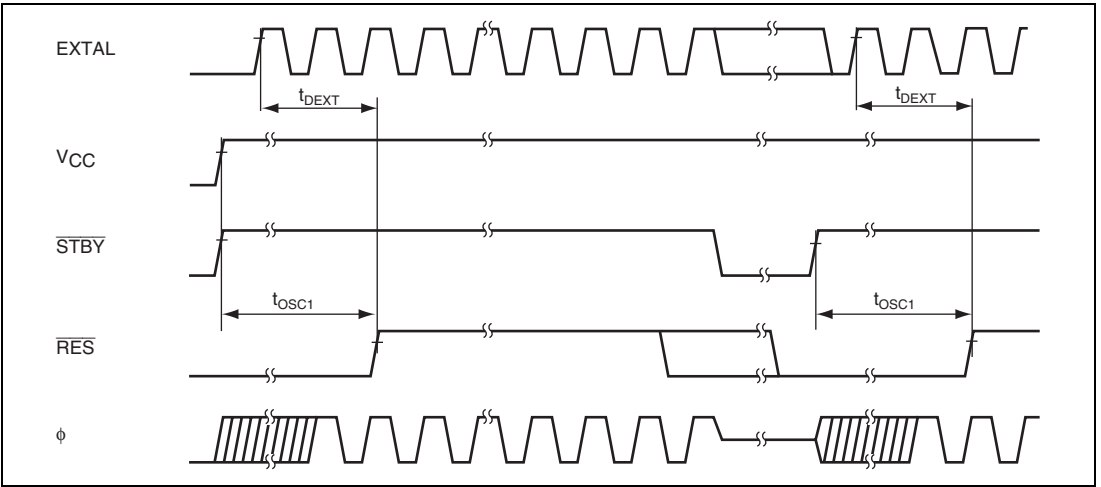

Figure 22.6 Oscillation Settling Timing

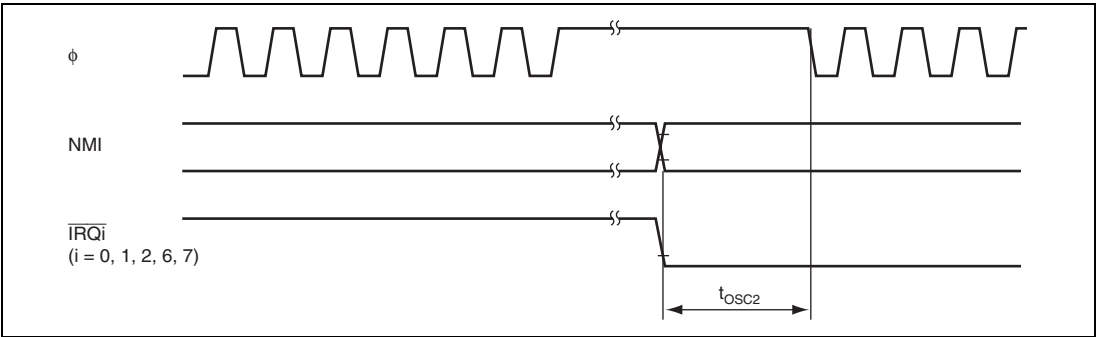

Figure 22.7 Oscillation Setting Timing (Exiting Software Standby Mode)

22.7.2 Control Signal Timing

The control signal timings are shown below.

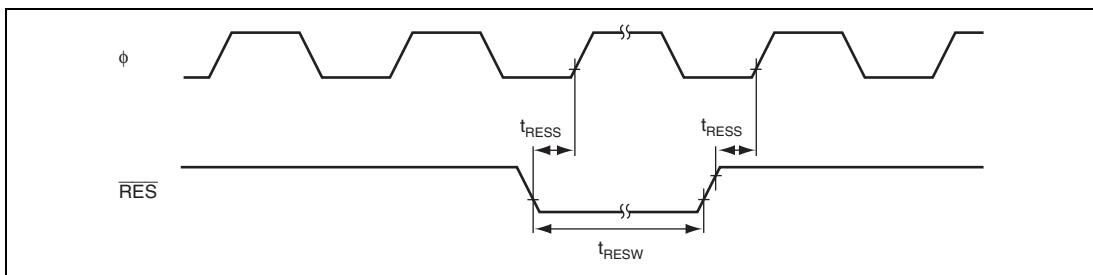

Figure 22.8 Reset Input Timing

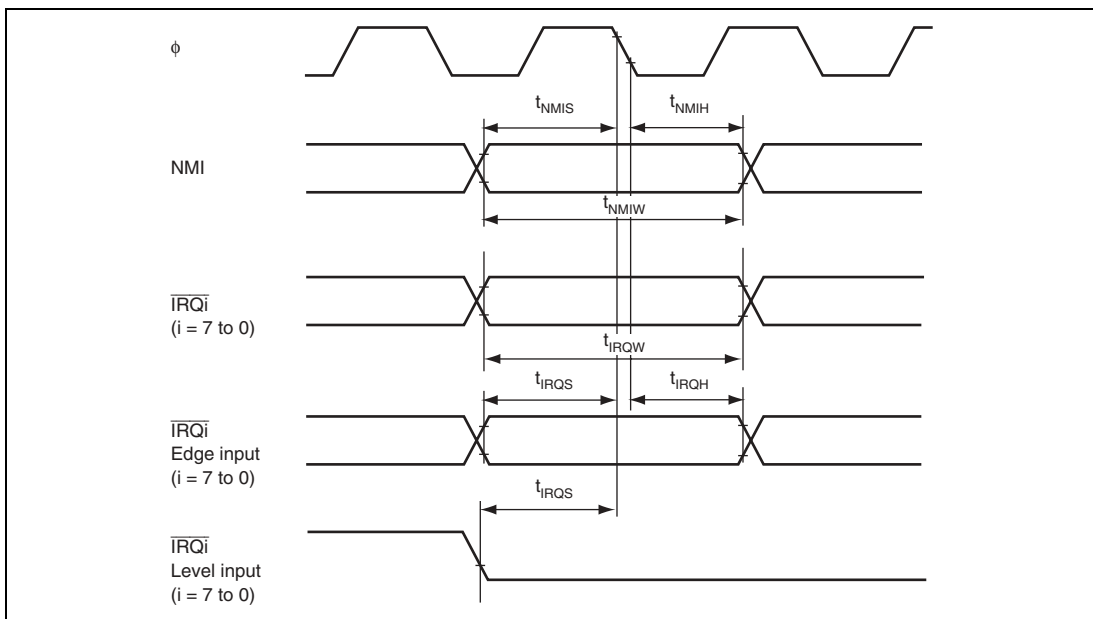

Figure 22.9 Interrupt Input Timing

22.7.3 On-Chip Peripheral Module Timing

The on-chip peripheral module timings are shown below.

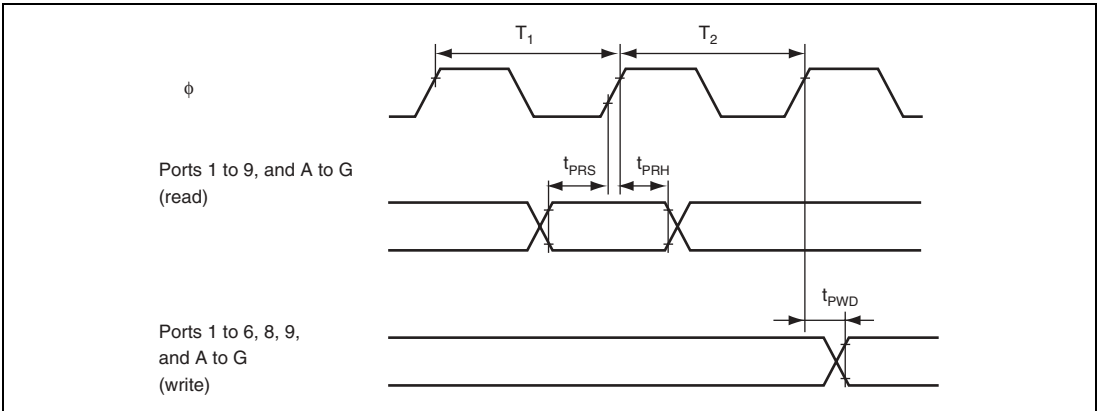

Figure 22.10 I/O Port Input/Output Timing

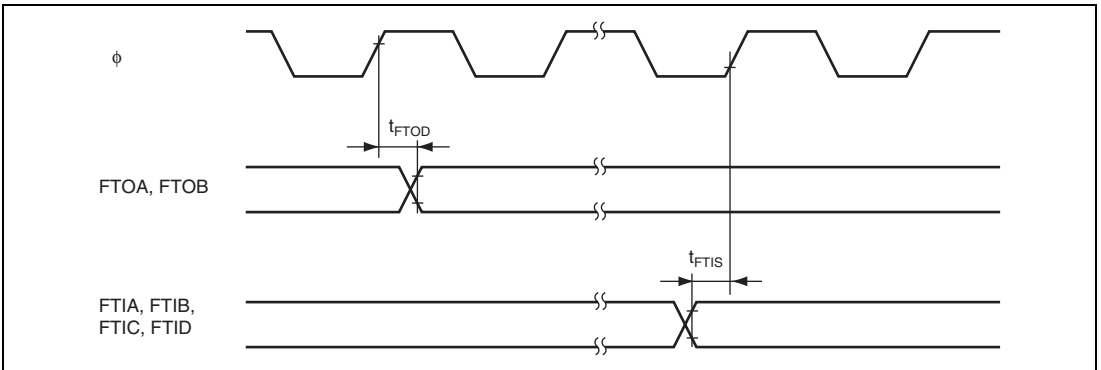

Figure 22.11 FRT Input/Output Timing

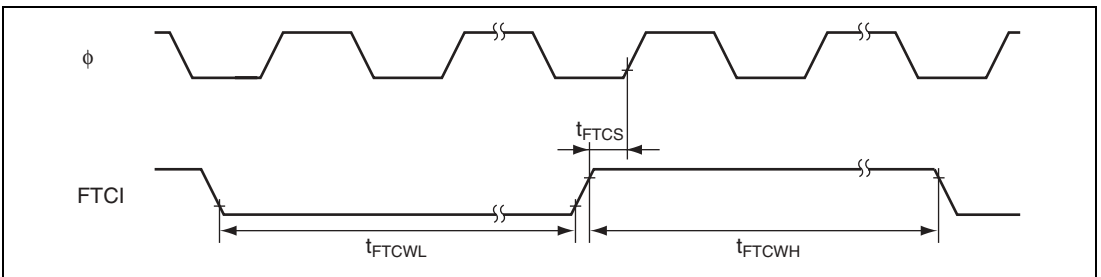

Figure 22.12 FRT Clock Input Timing

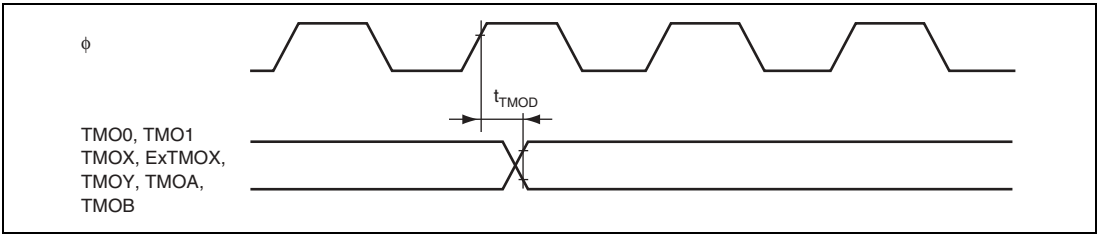

Figure 22.13 8-Bit Timer Output Timing

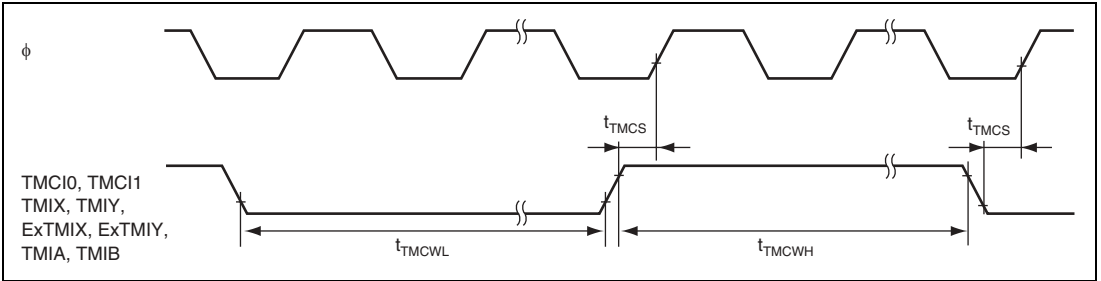

Figure 22.14 8-Bit Timer Clock Input Timing

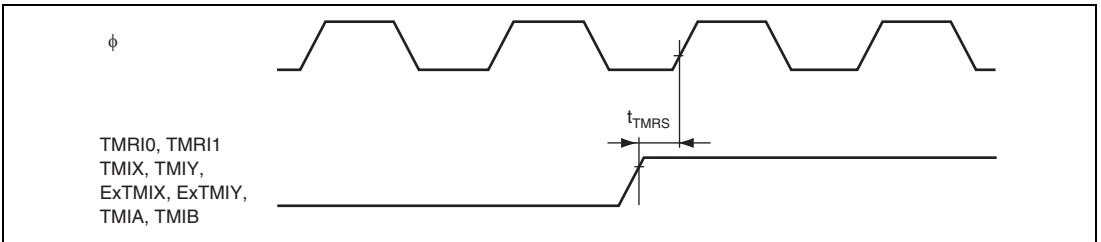

Figure 22.15 8-Bit Timer Reset Input Timing

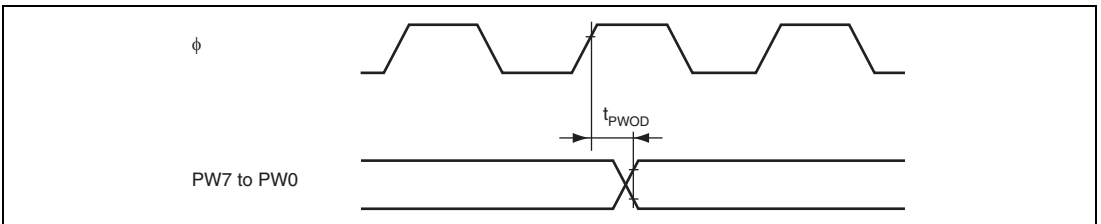

Figure 22.16 PWM, PWMX Output Timing

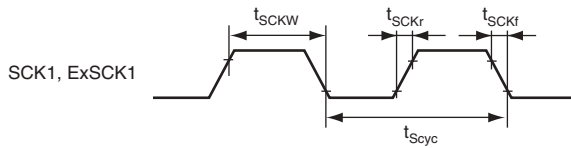

Figure 22.17 SCK Clock Input Timing

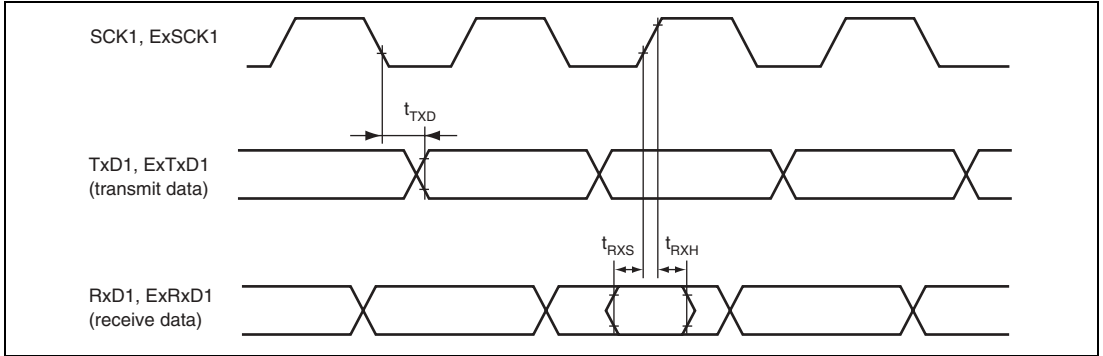

Figure 22.18 SCI Input/Output Timing (Synchronous Mode)

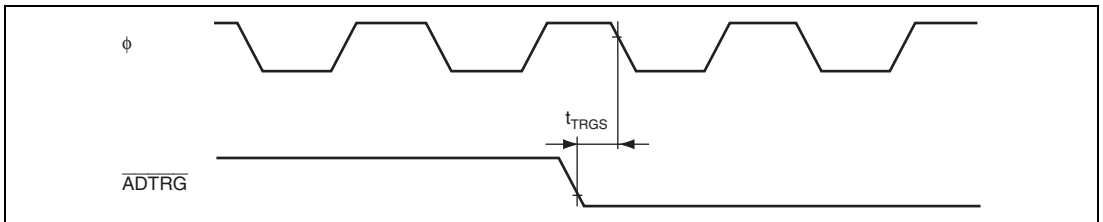

Figure 22.19 A/D Converter External Trigger Input Timing

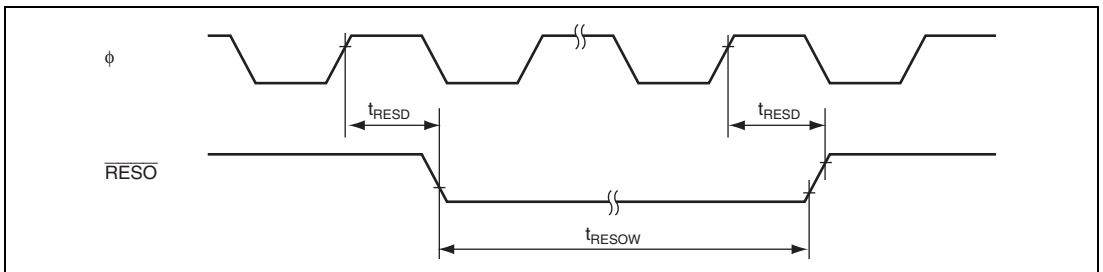

Figure 22.20 WDT Output Timing (\overline{RESO})

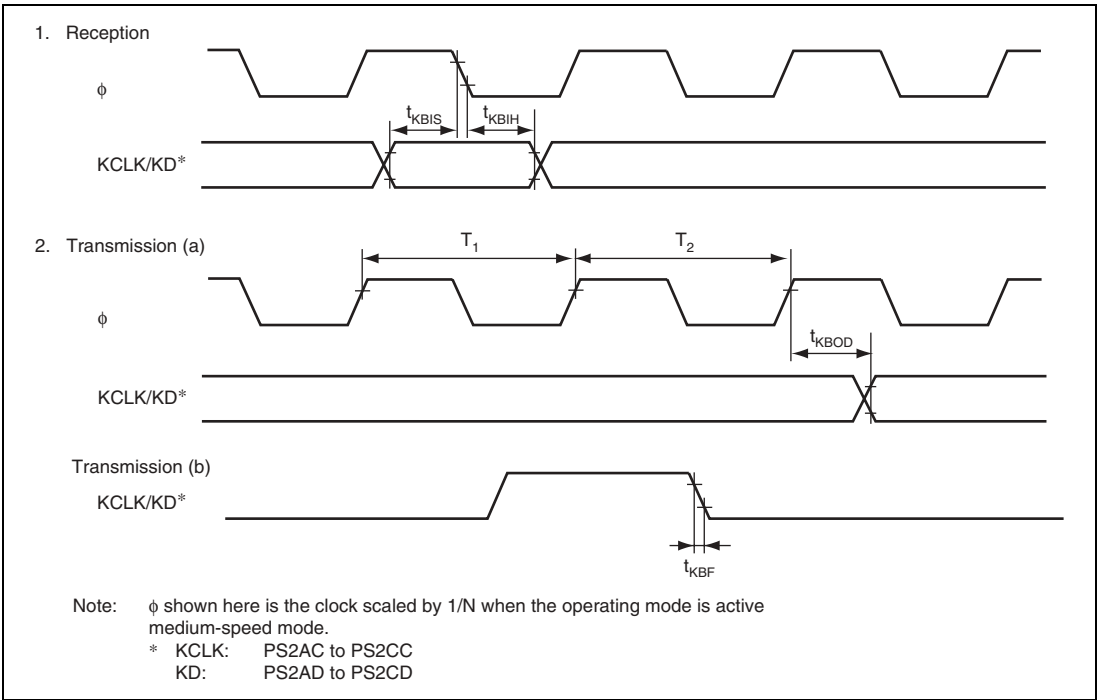

Figure 22.21 Keyboard Buffer Controller Timing

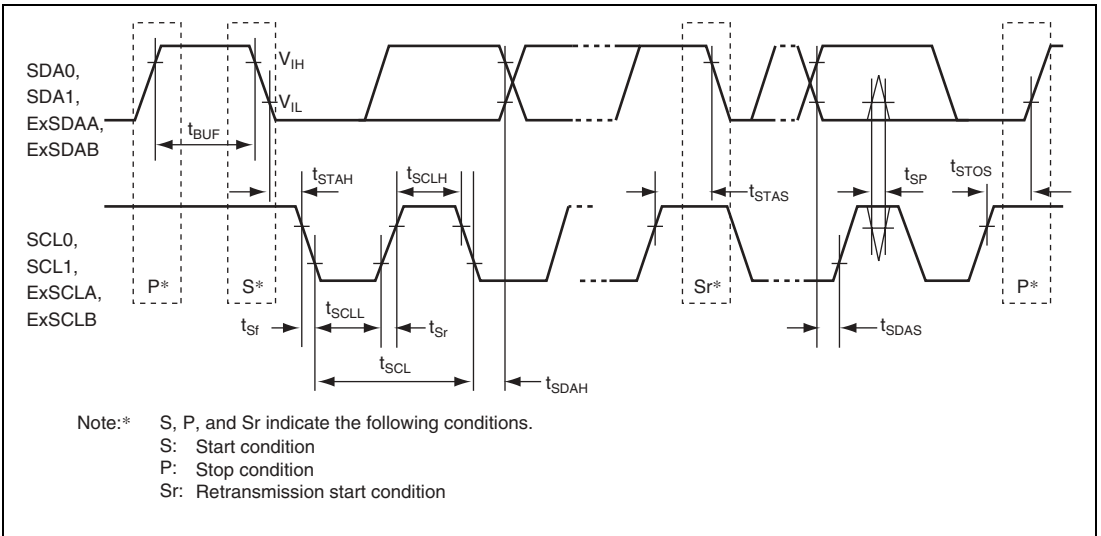

Figure 22.22 I²C Bus Interface Input/Output Timing

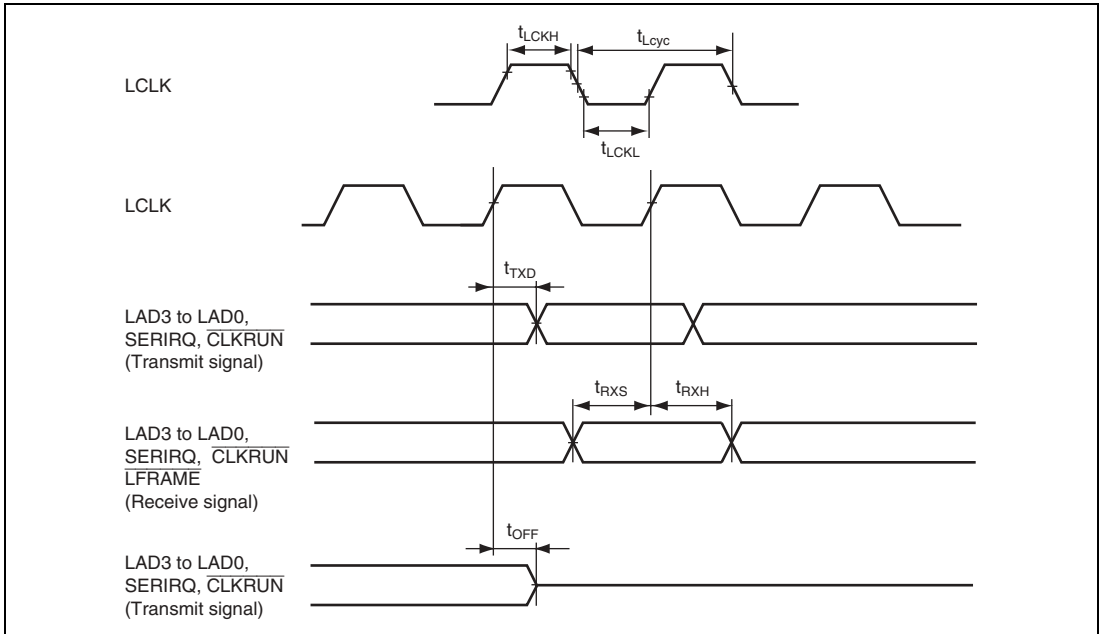

Figure 22.23 Host Interface (LPC) Timing

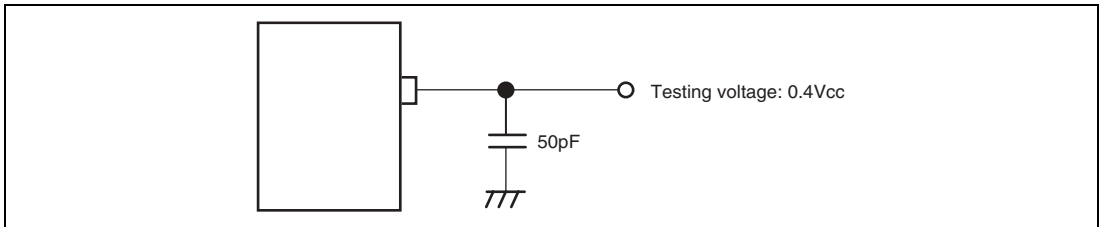

Figure 22.24 Tester Measurement Condition

Appendix

A. I/O Port States in Each Processing State

Table A.1 I/O Port States in Each Processing State

Port Name Pin Name	Reset	Hardware Standby Mode	Software Standby Mode	Watch Mode	Sleep Mode	Sub- sleep Mode	Subactive Mode	Program Execution State
Port 1	T	T	kept	kept	kept	kept	I/O port	I/O port
Port 2	T	T	kept	kept	kept	kept	I/O port	I/O port
Port 3	T	T	kept	kept	kept	kept	I/O port	I/O port
Port 4	T	T	kept	kept	kept	kept	I/O port	I/O port
Port 5	T	T	kept	kept	kept	kept	I/O port	I/O port
Port 6	T	T	kept	kept	kept	kept	I/O port	I/O port
Port 7	T	T	T	T	T	T	Input port	Input port
Port 8	T	T	kept	kept	kept	kept	I/O port	I/O port
Port 97	T	T	kept	kept	kept	kept	I/O port	I/O port
Port 96 ϕ EXCL	T	T	[DDR = 1] H [DDR = 0] T	EXCL input	[DDR = 1] clock output [DDR = 0] T	EXCL input	EXCL input	Clock output/ EXCL input/ input port
Ports 95 to 90	T	T	kept	kept	kept	kept	I/O port	I/O port
Port A	T	T	kept	kept	kept	kept	I/O port	I/O port
Port B	T	T	kept	kept	kept	kept	I/O port	I/O port
Ports C to G	T	T	kept	kept	kept	kept	I/O port	I/O port

[Legend]

H: High

L: Low

T: High-impedance state

kept: Input ports are in the high-impedance state (when DDR = 0 and PCR = 1, input pull-up MOSs remain on).

Output ports maintain their previous state.

Depending on the pins, the on-chip peripheral modules may be initialized and the I/O port function determined by DDR and DR used.

DDR: Data direction register

B. Product Codes

Product Type		Product Code	Mark Code	Package (Package Code)
H8S/2111B-B	Flash memory version	HD64F2111BVB	F2111BVTE10B	144-pin TQFP (TFP-144)
H8S/2111B-C	(3 V version)	HD64F2111BVC	F2111BVTE10C	

C. Package Dimensions

For package dimensions, dimensions described in Renesas Semiconductor Packages Data Book have priority.

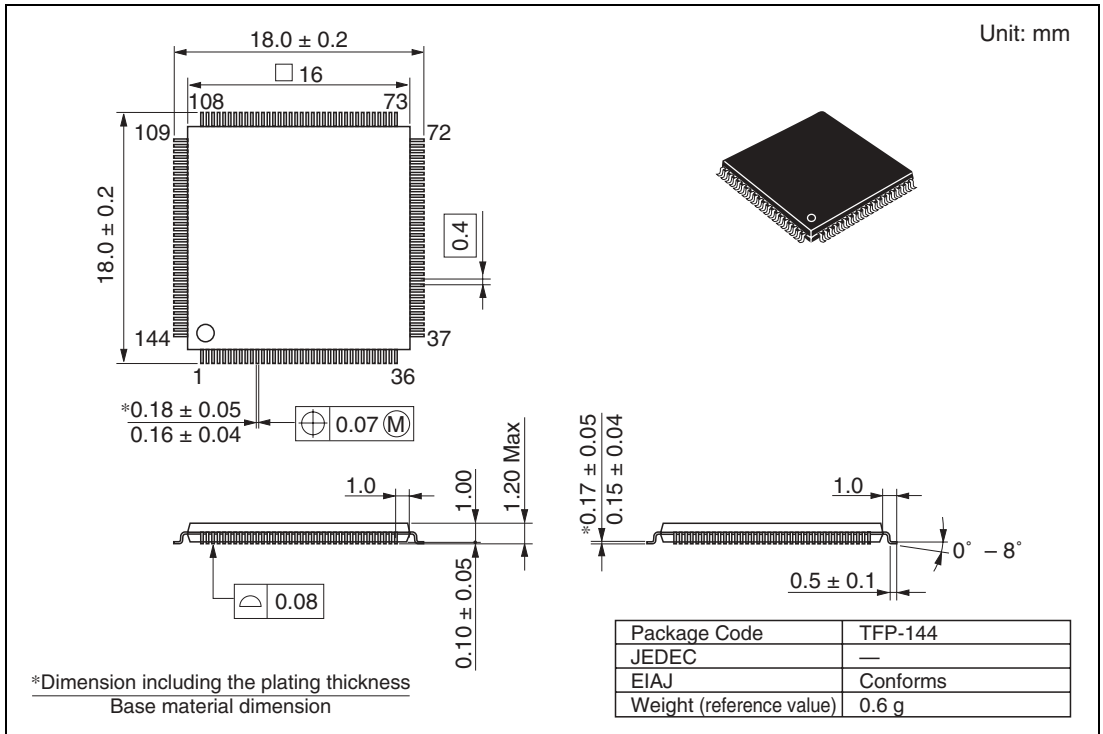

Figure C.1 Package Dimensions (TFP-144)

Index

16-bit count mode.....	210	CMIBAB.....	215
16-bit free-running timer (FRT)	157	CMIBY	215
8-bit PWM timer (PWM).....	147	Compare-match count mode	210
8-bit timer (TMR).....	183	Condition field	39
A/D converter	413	Condition-code register.....	24
A20 gate.....	398	Conversion time	421
Absolute address.....	41	Crystal resonator	456
Additional pulse.....	154	Data transfer instructions	31
Address map	57	Direct transitions.....	477
Address space	20	EEPMOV instruction	49
Addressing modes.....	40	Effective address	40, 44
ADI	423	Effective address extension.....	39
Analog input channel.....	416	Electrical characteristics	513
Arithmetic operations instructions.....	32	Erase/erase-verify	448
Asynchronous mode	249	Erasing units	436
Basic pulse.....	153	ERRI	408
Bcc.....	37	Error protection	450
Bit manipulation instructions.....	35	Exception handling	59
Bit rate	244	Exception handling vector table.....	60
Block data transfer instructions	38	Exception vector table.....	60
Boot mode	442	Extended control register	23
Branch instructions	37	External trigger	422
Break.....	272	Flash memory	431
Buffered input capture input.....	173	FOV	177
Bus controller (BSC)	93	Framing error	256
.....	93	General registers	22
Carrier frequency	149	Hardware protection.....	450
Cascaded connection	210	Hardware standby mode.....	473
Clear timing	171	Host interface (LPC).....	367
Clock pulse generator	455	I/O ports	95
Clocked synchronous mode.....	264	I ² C bus data format	307
CMI.....	215	I ² C bus interface (IIC).....	277
CMIA.....	215	ICI	177
CMIAAB	215	ICIA	215
CMIA Y	215		
CMIB.....	215		

ICIX.....	215	Parity error.....	256
IICI.....	337	Power-down modes.....	463
Immediate.....	42	Program counter.....	23
Increment timing.....	170	Program/erase protection.....	450
Input capture input.....	172	Program/program-verify.....	446
Input capture operation.....	212	Program-counter relative.....	42
Instruction set.....	29	Programmer mode.....	452
Interrupt control modes.....	80	Pulse output.....	169
Interrupt controller.....	67	PWM conversion period.....	149
Interrupt exception handling.....	63		
Interrupt Exception handling vector table	78	RAM.....	429
Interrupt mask bit.....	24	Register direct.....	40
Interval timer mode.....	229	Register field.....	39
		Register indirect.....	40
Keyboard buffer controller.....	349	Register indirect with displacement.....	41
		Register indirect with post-increment.....	41
Logic operations instructions.....	34	Register indirect with pre-decrement.....	41
		Registers	
Mark state.....	272	ABRKCR.....	70, 483, 492, 500, 508
MCU operating mode selection.....	51	ADCR.....	418, 487, 495, 503, 511
MCU operating modes.....	51	ADCSR.....	417, 487, 495, 503, 511
Medium-speed mode.....	470	ADDR.....	416, 487, 495, 503, 511
Memory indirect.....	43	BAR.....	71, 483, 492, 500, 508
Mode 2.....	56	BCR.....	93, 486, 494, 502, 510
Mode 3.....	56	BRR.....	244
Mode pins.....	51	DDCSWR.....	301, 483, 491, 499, 507
Module stop mode.....	477	EBR1.....	440, 483, 492, 500, 508
Multiprocessor communication		EBR2.....	440, 483, 492, 500, 508
function.....	259	FLMCR1.....	438, 483, 492, 500, 508
		FLMCR2.....	439, 483, 492, 500, 508
NMI interrupt.....	76, 230	FRC.....	160, 484, 493, 501, 508
Noise canceler.....	335	HICR0.....	371, 481, 490, 498, 506
Note on bit manipulation instructions.....	48	HICR1.....	371, 481, 490, 498, 506
		HICR2.....	377, 481, 490, 498, 506
OCI.....	177	HICR3.....	377, 481, 490, 498, 506
On-board programming modes.....	441	HISEL.....	395, 481, 490, 498, 506
Operation field.....	39	ICCR.....	289, 486, 495, 503, 511
Output compare output.....	171	ICDR.....	282, 486, 495, 503, 511
Overrun error.....	256	ICMR.....	286, 487, 495, 503, 511
OVI.....	215	ICR.....	69, 160, 483, 484, 492,
OVIAB.....	215		493, 500, 501, 508, 509
OVIY.....	215	ICSR.....	297, 486, 495, 503, 511

ICXR	302, 482, 491, 499, 507	PCDDR	132, 482, 491, 499, 507
IDR	380, 481, 490, 498, 506	PCNOCR	134, 480, 489, 497, 505
IER	73, 486, 494, 502, 510	PCODR	133, 482, 491, 499, 507
ISCR	72, 483, 492, 500, 508	PCPIN	133, 482, 491, 499, 507
ISR	73, 483, 492, 500, 508	PCSR	152, 483, 492, 500, 508
KBBR	354, 482, 491, 499, 507	PDDDR	132, 482, 491, 499, 507
KBCR	351, 482, 491, 499, 507	PDNOCR	134, 480, 489, 497, 505
KMIMR	73, 487, 496, 504, 512	PDODR	133, 482, 491, 499, 507
KMIMRA	73, 487, 496, 504, 512	PDPIN	133, 482, 491, 499, 507
KMPCR	113, 487, 496, 504, 512	PEDDR	136, 482, 491, 499, 507
LADR3	379, 481, 490, 498, 506	PENOCR	140, 480, 489, 497, 505
LPWRCR	465, 484, 492, 500, 508	PEODR	137, 482, 491, 499, 507
MDCR	52, 486, 494, 502, 510	PEPIN	138, 482, 491, 499, 507
MSTPCR	467, 484, 492, 500, 508	PFDDR	136, 482, 491, 499, 507
OCR	160, 484, 493, 501, 509	PFNOCR	140, 480, 489, 497, 505
OCRDM	161	PFODR	137, 482, 491, 499, 507
ODR	381, 481, 490, 498, 506	PFPIN	138, 482, 491, 499, 507
P1DDR	100, 485, 494, 502, 510	PGCTL	306, 480, 489, 497, 505
P1DR	100, 485, 494, 502, 510	PGDDR	142, 482, 491, 499, 507
P1PCR	101, 485, 494, 502, 510	PGNOCR	145, 480, 489, 497, 505
P2DDR	102, 485, 494, 502, 510	PGODR	143, 482, 491, 499, 507
P2DR	103, 485, 494, 502, 510	PGPIN	143, 482, 491, 499, 507
P2PCR	103, 485, 494, 502, 510	PWDPR	151
P3DDR	104, 485, 494, 502, 510	PWDR	151, 486, 495, 503, 511
P3DR	105, 485, 494, 502, 510	PWOER	152
P3PCR	105, 485, 494, 502, 510	PWSL	149, 486, 495, 503, 511
P4DDR	107, 485, 494, 502, 510	RDR	237
P4DR	107, 485, 494, 502, 510	RSR	237
P5DDR	110, 485, 494, 502, 510	SAR	283, 487, 495, 503, 511
P5DR	110, 485, 494, 502, 510	SARX	284, 486, 495, 503, 511
P6DDR	112, 485, 494, 502, 510	SBYCR	464, 483, 492, 500, 508
P6DR	113, 485, 494, 502, 510	SCMR	243
P7PIN	117, 486, 494, 502, 510	SCR	239
P8DDR	118, 486, 494, 502, 510	SIRQCR	387, 481, 490, 498, 506
P8DR	118, 486, 494, 502, 510	SMR	238
P9DDR	122, 486, 494, 502, 510	SPSR	249
P9DR	122, 486, 494, 502, 510	SSR	241
PADDR	125, 485, 494, 502, 510	STCR	55, 486, 494, 502, 510
PAODR	125, 485, 494, 502, 510	STR	381, 481, 490, 498, 506
PAPIN	126, 485, 494, 502, 510	SYSCR	53, 486, 494, 502, 510
PBDDR	129, 486, 494, 502, 510	SYSCR2	114, 483, 492, 500, 508
PBODR	129, 485, 494, 502, 510	TCNT	191, 233, 485, 486, 493, 495, 501, 503, 509, 511
PBPIN	130, 485, 494, 502, 510		

TCONRI	203, 488, 496, 504, 512	ROM	431
TCONRS	203, 488, 496, 504, 512	Serial communication interface (SCI).....	235
TCOR	191, 486, 495, 503, 511	Serial formats	307
TCORC.....	202, 488, 496, 504, 512	Shift instructions	34
TCR	166, 192, 484, 486, 493,	Single mode	419
	495, 501, 503, 509, 511	Sleep mode.....	471
TCRAB.....	205	SMI	409
TCRXY	204	Software protection.....	450
TCSR	163, 196, 224, 484, 485,	Software standby mode.....	471
	486, 493, 495, 501, 503,	Stack pointer	22
	508, 509, 511	Stack status	64
TDR	237	Subactive mode.....	476
TICRF	202, 488, 496, 504, 512	Subsleep mode	475
TICRR	202, 487, 496, 504, 512	System control instructions.....	38
TIER	162, 484, 493, 501, 508	Trap instruction exception handling	63
TISR	202, 488, 496, 504, 512	User program mode	445
TOCR	167, 484, 493, 501, 509	Watch mode	474
TSR.....	238	Watchdog timer (WDT).....	221
TWR.....	381, 481, 490, 497, 506	Watchdog timer mode.....	227
WSCR.....	94, 486, 494, 502, 510	WOVI	230
WUEMRB	73, 482, 491, 499, 507		
Reset	61		
Reset exception handling.....	61		
Resolution.....	149		

**Renesas 16-Bit Single-Chip Microcomputer
Hardware Manual
H8S/2111B**

Publication Date: Rev.1.00, May 14, 2004

Published by: Sales Strategic Planning Div.
Renesas Technology Corp.

Edited by: Technical Documentation & Information Department
Renesas Kodaira Semiconductor Co., Ltd..

Renesas Technology Corp. Sales Strategic Planning Div. Nippon Bldg., 2-6-2, Ohte-machi, Chiyoda-ku, Tokyo 100-0004, Japan



RENESAS SALES OFFICES

<http://www.renesas.com>

Renesas Technology America, Inc.
450 Holger Way, San Jose, CA 95134-1368, U.S.A
Tel: <1> (408) 382-7500 Fax: <1> (408) 382-7501

Renesas Technology Europe Limited.
Dukes Meadow, Millboard Road, Bourne End, Buckinghamshire, SL8 5FH, United Kingdom
Tel: <44> (1628) 585 100, Fax: <44> (1628) 585 900

Renesas Technology Europe GmbH
Dornacher Str. 3, D-85622 Feldkirchen, Germany
Tel: <49> (89) 380 70 0, Fax: <49> (89) 929 30 11

Renesas Technology Hong Kong Ltd.
7/F., North Tower, World Finance Centre, Harbour City, Canton Road, Hong Kong
Tel: <852> 2265-6688, Fax: <852> 2375-6836

Renesas Technology Taiwan Co., Ltd.
FL 10, #99, Fu-Hsing N. Rd., Taipei, Taiwan
Tel: <886> (2) 2715-2888, Fax: <886> (2) 2713-2999

Renesas Technology (Shanghai) Co., Ltd.
26/F., Ruijin Building, No.205 Maoming Road (S), Shanghai 200020, China
Tel: <86> (21) 6472-1001, Fax: <86> (21) 6415-2952

Renesas Technology Singapore Pte. Ltd.
1, Harbour Front Avenue, #06-10, Keppel Bay Tower, Singapore 098632
Tel: <65> 6213-0200, Fax: <65> 6278-8001

H8S/2111B Hardware Manual



Renesas Technology Corp.

2-6-2, Ote-machi, Chiyoda-ku, Tokyo, 100-0004, Japan